



Fantech

Your Ventilation Solutions Company

SER Series Energy Recovery Ventilator

**IMPORTANT - PLEASE READ THIS MANUAL
BEFORE INSTALLING UNIT**

CAUTION - Before installation, careful consideration must be given to how this system will operate if connected to any other piece of mechanical equipment, i.e. a forced air furnace or air handler, operating at a higher static. After installation, the compatibility of the two pieces of equipment must be confirmed by measuring the airflow's of the Energy Recovery Ventilators by using the balancing procedure found in this manual. It is always important to assess how the operation of any ERV may interact with vented combustion equipment (i.e. Gas Furnaces, Oil Furnaces, Wood Stoves, etc.).

NEVER - install a ventilator in a situation where its normal operation, lack of operation or partial failure may result in the backdrafting or improper functioning of vented combustion equipment!!!



Your ventilation system should be installed in conformance with the appropriate state requirements or in the absence of such requirements ASHRAE's " Good Engineering Practices".

SER Models

SER 1504, SER 1504N, SER 2004, SER 2004N, SER 3204D & SER 3204N

INSTALLATION, OPERATION AND MAINTENANCE MANUAL

The Best Limited Warranty in the Business

- The energy recovery enthalpic core has a limited 5 year warranty.
- The motors found in all Fantech ERV's require no lubrication, and are factory balanced to prevent vibration and promote silent operation.
- The limited warranty covers normal use. It does not apply to any defects, malfunctions or failures as a result of improper installation, abuse, mishandling, misapplication, unfortuitous occurrence or any other circumstances outside Fantech's control.
- Inappropriate installation or maintenance may result in the cancellation of the warranty.
- Any unauthorized work will result in the cancellation of the warranty.
- Fantech is not responsible for any incidental or consequential damages incurred in the use of the ventilation system.
- Fantech is not responsible for providing an authorized service centre near the purchaser or in the general area.
- Fantech reserves the right to supply refurbished parts as replacements.
- Transportation, removal and installation fees are the responsibility of the purchaser.
- The purchaser is responsible to adhering to all codes in effect in his area.
- The warranty is limited to 5 years on parts and 7 years on the motor from the date of purchase, including parts replaced during this time period. If there is no proof of purchase available, the date associated with the serial number will be used for the beginning of the warranty period.
- * This warranty is the exclusive and only warranty in effect relative to the ventilation system and all other warranties either expressed or implied are invalid.

TABLE OF CONTENTS

TECHNICAL DATA	
SER 1504	3
SER 1504N	5
SER 2004	7
SER 2004N	9
SER 3204D	11
SER 3204N	13
OPERATION	
Modes Of Operation	15
Optional Remote Controls	16
Intellitek Multi-Function Controls EDF5	16
Intellitek Multi-Function Controls EDF2	17
INSTALLATION	
Mounting the Unit	18
Location & Ducting	19
Examples	22
Air Flow Balancing	26
MAINTENANCE	
TROUBLESHOOTING	
ELECTRICAL CONNECTIONS	
WIRING DIAGRAMS	

Sizing (Example) for maximum airflow normally required.

ERVs are typically sized to ventilate the whole house at a minimum of 0.35 air changes per hour. To calculate, simply take the square footage of the house (including basement) and multiply by the height of the ceiling to get cubic volume. Then, divide by 60 and multiply by 0.35.

Example:	Sq Ft of House	1100	
	Basement	1100	(if applicable)
	Total Sq Ft	2200	
	Height of ceiling	x 8	
	Cubic volume	17600	
		/ 60	
	Maximum airflow required (CFM)	293	
		x 0.35	
		103	

* Always consult your local code for sizing requirements in your area.

***** Illustrations & images in this manual may not be exactly like unit purchased, these illustrations & images are for examples only. *****



Fantech

Energy Recovery Ventilator

SER Series

SER 1504



SPECIFICATIONS

CASE 24 gauge galvanized steel. Baked powder coated paint, antique white. Insulated with 1" (25 mm) high density polystyrene foam to prevent condensation and meet the requirements of the Underwriters Laboratories 94HF.

MOTORS Two (2) German-engineered, factory-balanced ebm™ motors with backward curved blades. Motors come with permanently lubricated sealed ball bearings guarantee long life and maintenance-free operation. Seven (7) year warranty.

CORE A enthalpy energy recovery core configured for an efficient cross-flow ventilation. Core is 9" x 9" (229 x 229 mm) with a 15" (380 mm) depth. Cores are manufactured to withstand extreme temperature variations.

FILTERS Two (2) Washable Electrostatic Panel Type Air Filters, SER 1504 is 8.5" (216mm) x 15" (380mm) x 0.125" (3mm),

CONTROLS External three (3) position (Low/Stand By/Medium) rocker switch that will offer continuous ventilation. Fantech offers a variety of external controls. (see optional controls)

DEFROST During the defrost sequence, the supply blower shuts down and the exhaust blower switches into high speed to maximize the effectiveness of the defrost strategy.

FEATURES

- Compact design
- Backward curved impellers
- Electrostatic filters (washable)
- Enthalpy energy recovery core
- External screw type dry contacts for optional controls
- Improved core guide channels for easy removal of core

OPTIONAL CONTROLS

- EDF 5 – Digital multi-function wall control with cycle timer
- EDF 2 – Digital multi-function wall control
- MDEH 2 – Mechanical low voltage dehumidistat with On/Off switch
- MDEH 1 – Mechanical low voltage dehumidistat
- RTS 2 – 15 Minute pushbutton timer
- FD 30M – 30 Minute crank timer
- AQS 1 – Air quality sensor

WARRANTY

- 7 year on motors
- 5 year on parts
- 5 year on core (limited)

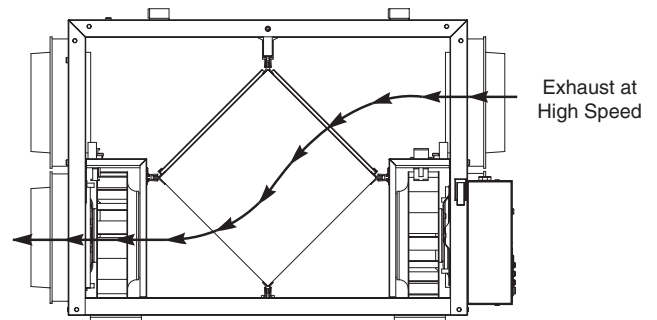

INSTALLATION Unit is typically hung by using installation kit supplied with unit. Mounting bolts provided on top four (4) corners of unit.

SERVICEABILITY Core, filters, motors and drain pan can be easily serviced through latched access door. Core conveniently slides out with ease on an improved railing system. Electrical box, placed on the outside of the unit, can also be easily accessed.

Distributed by:

Fantech, reserves the right to modify, at any time and without notice, any or all of its products' features, designs, components and specifications to maintain their technological leadership position.

Dimensions & Airflow - All units feature three foot plug-in power cord with 3-prong plug on top of electrical box.

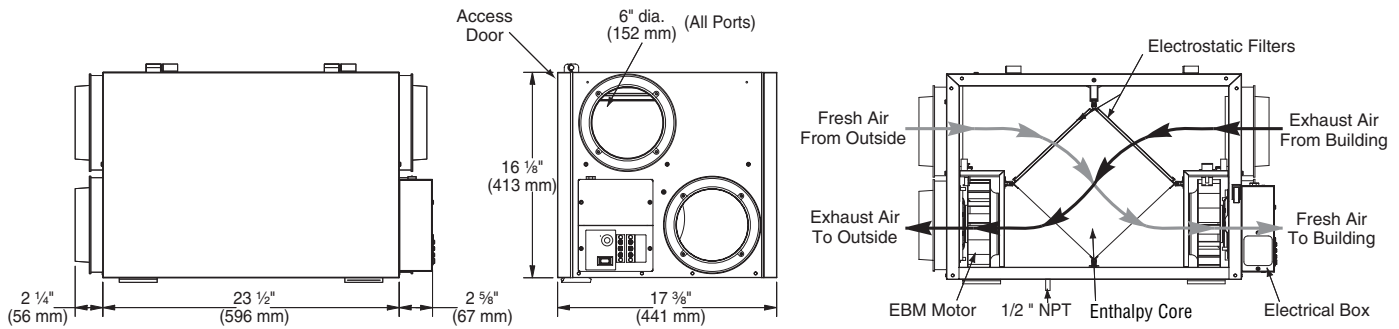

Ventilation Performance

EXT. STATIC PRESSURE		NET SUPPLY AIR FLOW		GROSS AIR FLOW SUPPLY				EXHAUST	
Pa	in wg	L/s	cfm	L/s	cfm	L/s	cfm	L/s	cfm
25	0.1	77	162	77	162	77	162	77	162
50	0.2	72	152	72	152	72	152	72	152
75	0.3	67	143	67	143	67	143	67	143
100	0.4	63	134	63	134	63	134	63	134
125	0.5	60	127	60	127	60	127	60	127
150	0.6	57	121	57	121	57	121	57	121
175	0.7	54	115	54	115	54	115	54	115
200	0.8	51	108	51	108	51	108	51	108

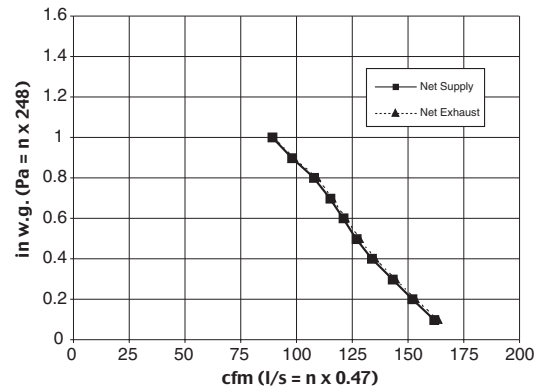

Energy Performance

	SUPPLY TEMPERATURE		NET AIRFLOW		POWER CONSUMED WATTS	SENSIBLE RECOVERY EFFICIENCY	APPARENT SENSIBLE EFFECTIVENESS	NET MOISTURE TRANSFER
	°C	°F	L/s	cfm				
Heating	0	32	30	64	67	70%	82%	0.58
	0	32	39	83	121	66%	79%	0.56
	0	32	57	121	168	61%	74%	0.55
Total Recovery Efficiency								
Cooling	35	95	30	64	66	44%		
	35	95	55	117	143	36%		

Specifications and Ratings

- Model: SER 1504
- Total assembled weight: 45 lbs
- Cabinet: 24 ga. steel w/ powder coat finish
- Motors: ebm motor w/backward curved blades
- Filters: 2 washable electrostatic filters 8.5" (216mm) x 15" (380mm) x 0.125" (3mm)
- Insulated with 1" (25 mm) high density polystyrene foam to prevent condensation and meet the requirements of the Underwriters Laboratories 94HF.
- Core: Enthalpy 9" (229mm) x 9" (229 mm) x 15" (380 mm)
- Supply & exhaust ducts: 6" (152.4mm)
- Mounting: Suspended by chains & hooks
- Electrical requirements:

Volts	Frequency	Amps	Watts	High Speed
120V	60Hz	1.5A	150W	

Contacts

Submitted by: _____	Date: _____
Qty: _____	Model #: _____
Comments: _____	
Project #: _____	
Location: _____	
Architect: _____	
Engineer: _____	
Contractor: _____	



United States

1712 Northgate Blvd.
 Sarasota, FL. 34234
 Phone: 800.747.1762; 941.309.6000
 Fax: 800.487.9915; 941.309.6099
 www.fantech.net
 info@fantech.net

Canada

50 Kanalfakt Way
 Bouctouche, NB E4S 3M5
 Phone: 800.565.3548; 506.743.9500
 Fax: 877.747.8116; 506.743.9600
 www.fantech.ca
 info@fantech.ca

Article #: 301XXX
 Rev Date: 110104



Fantech

Energy Recovery Ventilator

SER Series

SER 1504N



SPECIFICATIONS

CASE 24 gauge galvanized steel. Baked powder coated paint, antique white. Insulated with 1" (25 mm) high density polystyrene foam to prevent condensation and meet the requirements of the Underwriters Laboratories 94HF.

MOTORS Two (2) German-engineered, factory-balanced ebm™ motors with backward curved blades. Motors come with permanently lubricated sealed ball bearings guarantee long life and maintenance-free operation. Seven (7) year warranty.

CORE A enthalpy energy recovery core configured for an efficient cross-flow ventilation. Core is 9" x 9" (229 x 229 mm) with a 15" (380 mm) depth. Cores are manufactured to withstand extreme temperature variations.

FILTERS Two (2) Washable Electrostatic Panel Type Air Filters, they are 8.5" (216mm) x 15" (380mm) x 0.125" (3mm).

PORT SELECTION (Reversing Unit) Units are shipped indicating airflow (see "Dimensions & Airflow" on next page). These ports can be selected on site by the installer and changed around as needed. IE "Exhaust Air From Building" could be changed to "Air From Outside" and "Exhaust To Outside" switched to "Air To Building". The same is true for the other ports. This gives the installer greater flexibility in placement of the unit and ductwork.

INSTALLATION Unit is typically hung by using installation kit supplied with unit. Mounting bolts provided on top four (4) corners of unit.

SERVICEABILITY Core, filters, and motors can be easily serviced through latched access door. Core conveniently slides out with ease on an improved railing system. Electrical box, placed on the outside of the unit, can also be easily accessed.

NOTE This model is not recommended for climates that experience temperatures below 23°F (-5°C) for more than 2 consecutive days.

FEATURES

- Compact design
- Backward curved impellers
- Electrostatic filters (washable)
- Enthalpy energy recovery core
- External screw type dry contacts for optional controls
- Improved core guide channels for easy removal of core

OPTIONAL CONTROLS

- EDF 5 – Digital multi-function wall control with cycle timer
- EDF 2 – Digital multi-function wall control
- RTS 2 – 15 Minute pushbutton timer
- FD 30M – 30 Minute crank timer
- AQS 1 – Air quality sensor

WARRANTY

- 7 year on motors
- 5 year on parts
- 5 year on core (limited)

Distributed by:

Dimensions & Airflow - All units feature three foot plug-in power cord with 3-prong plug on top of electrical box.

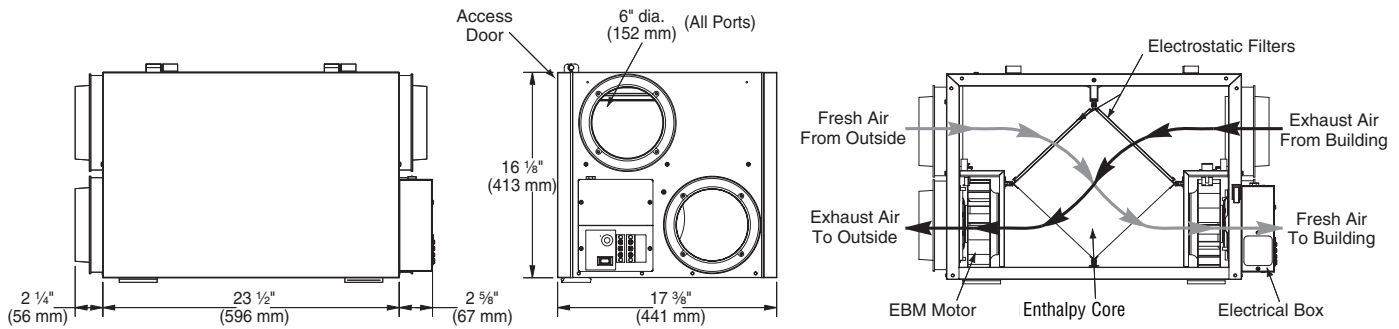

Ventilation Performance

EXT. STATIC PRESSURE		NET SUPPLY AIR FLOW		GROSS AIR FLOW SUPPLY				EXHAUST	
Pa	in wg	L/s	cfm	L/s	cfm	L/s	cfm	L/s	cfm
25	0.1	77	162	77	162	77	162	77	162
50	0.2	72	152	72	152	72	152	72	152
75	0.3	67	143	67	143	67	143	67	143
100	0.4	63	134	63	134	63	134	63	134
125	0.5	60	127	60	127	60	127	60	127
150	0.6	57	121	57	121	57	121	57	121
175	0.7	54	115	54	115	54	115	54	115
200	0.8	51	108	51	108	51	108	51	108

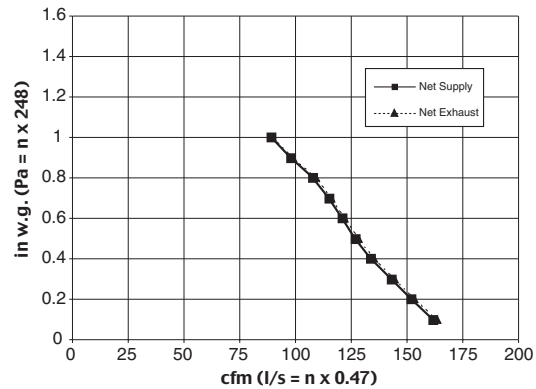

Energy Performance

	SUPPLY TEMPERATURE		NET AIRFLOW		POWER CONSUMED WATTS	SENSIBLE RECOVERY EFFICIENCY	APPARENT SENSIBLE EFFECTIVENESS	NET MOISTURE TRANSFER
	°C	°F	L/s	cfm				
Heating	0	32	30	64	67	70%	82%	0.58
	0	32	39	83	121	66%	79%	0.56
	0	32	57	121	168	61%	74%	0.55
Total Recovery Efficiency								
Cooling	35	95	30	64	66	44%		
	35	95	55	117	143	36%		

Enthalpy C

Specifications and Ratings

- Model: SER 1504N
- Total assembled weight: 45 lbs
- Cabinet: 24 ga. steel w/ powder coat finish
- Motors: ebm motor w/backward curved blades
- Filters: 2 washable electrostatic filters 8.5" (216mm) x 15" (380mm) x 0.125" (3mm)
- Insulated with 1" (25 mm) high density polystyrene foam to prevent condensation and meet the requirements of the Underwriters Laboratories 94HF.
- Core: Enthalpy 9" (229mm) x 9" (229 mm) x 15" (380 mm)
- Supply & exhaust ducts: 6" (152.4mm)
- Mounting: Suspended by chains & hooks
- Electrical requirements:

Volts	Frequency	Amps	Watts	High Speed
120V	60Hz	1.5A	150W	

Contacts

Submitted by:	Date:
Qty:	Model #:
Comments:	
Project #:	
Location:	
Architect:	
Engineer:	
Contractor:	



United States

1712 Northgate Blvd.
Sarasota, FL. 34234
Phone: 800.747.1762; 941.309.6000
Fax: 800.487.9915; 941.309.6099
www.fantech.net
info@fantech.net

Canada

50 Kanalfakt Way
Boucoucher, NB E4S 3M5
Phone: 800.565.3548; 506.743.9500
Fax: 877.747.8116; 506.743.9600
www.fantech.ca
info@fantech.ca

Article #: 301XXX
Rev Date: 110104



Fantech

Energy Recovery Ventilator

SER Series

SER 2004



SPECIFICATIONS

CASE 22 gauge galvanized steel. Baked powder coated paint, antique white. Insulated with 1" (25 mm) high density polystyrene foam to prevent condensation and meet the requirements of the Underwriters Laboratories 94HF.

MOTORS Two (2) German-manufactured, factory-balanced ebm™ motors with backward curved blades. Motors come with permanently lubricated sealed ball bearings guarantee long life and maintenance-free operation. Seven (7) year warranty.

CORE A enthalpy energy recovery core configured for an efficient cross-flow ventilation. Core is 12" x 12" (305 x 305 mm) with a 15" (380 mm) depth. Cores are manufactured to withstand extreme temperature variations.

FILTERS Two (2) Washable Electrostatic Panel Type Air Filters, they are 11.75" (298mm) x 15" (380mm) x 0.125" (3mm).

CONTROLS External three (3) position (Low/Stand By/Medium) rocker switch that will offer continuous ventilation. Fantech offers a variety of external controls. (see optional controls)

DEFROST During the defrost sequence, the supply blower shuts down and the exhaust blower switches into high speed to maximize the effectiveness of the defrost strategy.

FEATURES

- Compact design
- Backward curved impellers
- Electrostatic filters (washable)
- Enthalpy energy recovery core
- External screw type dry contacts for optional controls
- Improved core guide channels for easy removal of core

OPTIONAL CONTROLS

- EDF 5 – Digital multi-function wall control with cycle timer
- EDF 2 – Digital multi-function wall control
- MDEH 2 – Mechanical low voltage dehumidistat with On/Off switch
- MDEH 1 – Mechanical low voltage dehumidistat
- RTS 2 – 15 Minute pushbutton timer
- FD 30M – 30 Minute crank timer
- AQS 1 – Air quality sensor

WARRANTY

- 7 year on motors
- 5 year on parts
- 5 year on core (limited)

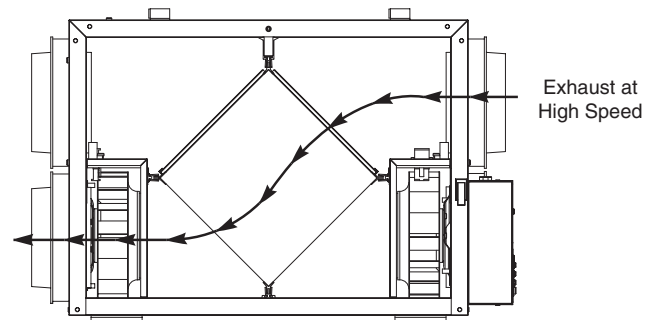

INSTALLATION Unit is typically hung by using installation kit supplied with unit. Mounting bolts provided on top four (4) corners of unit.

SERVICEABILITY Core, filters, motors and drain pan can be easily serviced through latched access door. Core conveniently slides out with ease on an improved railing system. Electrical box, placed on the outside of the unit, can also be easily accessed.

Distributed by:

Fantech, reserves the right to modify, at any time and without notice, any or all of its products' features, designs, components and specifications to maintain their technological leadership position.

Dimensions & Airflow - All units feature three foot plug-in power cord with 3-prong plug on front right hand side top of unit.

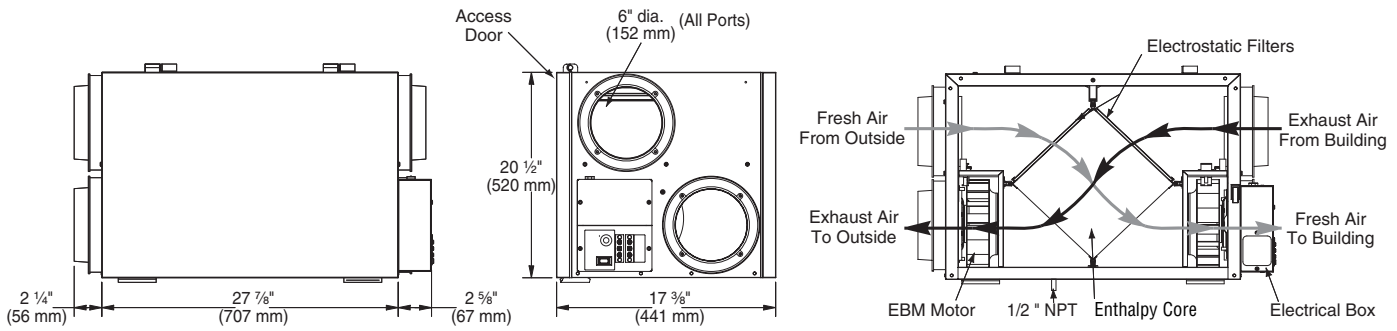

Ventilation Performance

EXT. STATIC PRESSURE		NET SUPPLY AIR FLOW		GROSS AIR FLOW SUPPLY				EXHAUST	
Pa	in wg	L/s	cfm	L/s	cfm	L/s	cfm	L/s	cfm
25	0.1	88	186	88	186	88	186	88	186
50	0.2	83	176	83	176	83	176	83	176
75	0.3	78	166	78	166	78	166	78	166
100	0.4	73	155	73	155	73	155	73	155
125	0.5	68	145	68	145	68	145	68	145
150	0.6	63	134	63	134	63	134	63	134
175	0.7	58	123	58	123	58	123	58	123
200	0.8	53	112	53	112	53	112	53	112
225	0.9	48	101	48	101	48	101	48	101
250	1.0	42	90	42	90	42	90	42	90

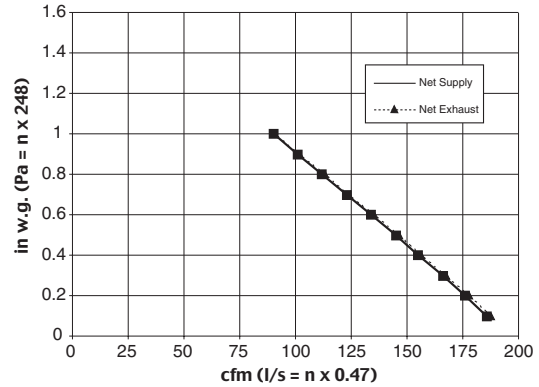

Energy Performance

	SUPPLY TEMPERATURE		NET AIRFLOW		POWER CONSUMED WATTS	SENSIBLE RECOVERY EFFICIENCY	APPARENT SENSIBLE EFFECTIVENESS	NET MOISTURE TRANSFER
	°C	°F	L/s	cfm				
Heating	0	32	30	64	62	81%	92%	0.78
	0	32	55	117	128	74%	86%	0.76
	0	32	76	161	194	70%	84%	0.71
							Total Recovery Efficiency	
Cooling	35	95	30	64	57	52%		
	35	95	55	117	130	46%		

Specifications and Ratings

- Model: SER 2004
- Total assembled weight: 61 lbs
- Cabinet: 22 ga. steel w/ powder coat finish
- Motors: ebm motor w/backward curved blades
- Filters: 2 washable electrostatic filters
- Insulated with 1" (25 mm) high density polystyrene foam to prevent condensation and meet the requirements of the Underwriters Laboratories 94HF.
- Core: Enthalpy
- Supply & exhaust ducts: 6" (152.4mm)
- Mounting: Suspended by chains & hooks
- Electrical requirements:

Volts	Frequency	Amps	Watts	High Speed
120V	60Hz	1.9A	150W	
- 3' plug-in power cord w/ 3-prong plug

Contacts

Submitted by: _____ Date: _____

Qty: _____ Model #: _____

Comments: _____

Project #: _____

Location: _____

Architect: _____

Engineer: _____

Contractor: _____



United States

1712 Northgate Blvd.
 Sarasota, FL. 34234
 Phone: 800.747.1762; 941.309.6000
 Fax: 800.487.9915; 941.309.6099
www.fantech.net
info@fantech.net

Canada

50 Kanalfakt Way
 Bouctouche, NB E4S 3M5
 Phone: 800.565.3548; 506.743.9500
 Fax: 877.747.8116; 506.743.9600
www.fantech.ca
info@fantech.ca

Article #: 301XXX
 Rev Date: 110104



Fantech

Energy Recovery Ventilator

SER Series

SER 2004N



SPECIFICATIONS

CASE 22 gauge galvanized steel. Baked powder coated paint, antique white. Insulated with 1" (25 mm) high density polystyrene foam to prevent condensation and meet the requirements of the Underwriters Laboratories 94HF.

MOTORS Two (2) German-manufactured, factory-balanced ebm™ motors with backward curved blades. Motors come with permanently lubricated sealed ball bearings guarantee long life and maintenance-free operation. Seven (7) year warranty.

CORE A enthalpy energy recovery core configured for an efficient cross-flow ventilation. Core is 12" x 12" (305 x 305 mm) with a 15" (380 mm) depth. Cores are manufactured to withstand extreme temperature variations.

FILTERS Two (2) Washable Electrostatic Panel Type Air Filters, they are 11.75" (298mm) x 15" (380mm) x 0.125" (3mm).

PORT SELECTION (Reversing Unit) Units are shipped indicating airflow (see "Dimensions & Airflow" on next page). These ports can be selected on site by the installer and changed around as needed. IE "Exhaust Air From Building" could be changed to "Air From Outside" and "Exhaust To Outside" switched to "Air To Building". The same is true for the other ports. This gives the installer greater flexibility in placement of the unit and ductwork.

INSTALLATION Unit is typically hung by using installation kit supplied with unit. Mounting bolts provided on top four (4) corners of unit.

SERVICEABILITY Core, filters, and motors can be easily serviced through latched access door. Core conveniently slides out with ease on an improved railing system. Electrical box, placed on the outside of the unit, can also be easily accessed.

NOTE This model is not recommended for climates that experience temperatures below 23°F (-5°C) for more than 2 consecutive days.

FEATURES

- Compact design
- Backward curved impellers
- Electrostatic filters (washable)
- Enthalpy energy recovery core
- External screw type dry contacts for optional controls
- Improved core guide channels for easy removal of core

OPTIONAL CONTROLS

- EDF 5 – Digital multi-function wall control with cycle timer
- EDF 2 – Digital multi-function wall control
- RTS 2 – 15 Minute pushbutton timer
- FD 30M – 30 Minute crank timer
- AQS 1 – Air quality sensor

WARRANTY

- 7 year on motors
- 5 year on parts
- 5 year on core (limited)

Distributed by:

Dimensions & Airflow - All units feature three foot plug-in power cord with 3-prong plug on front right hand side top of unit.

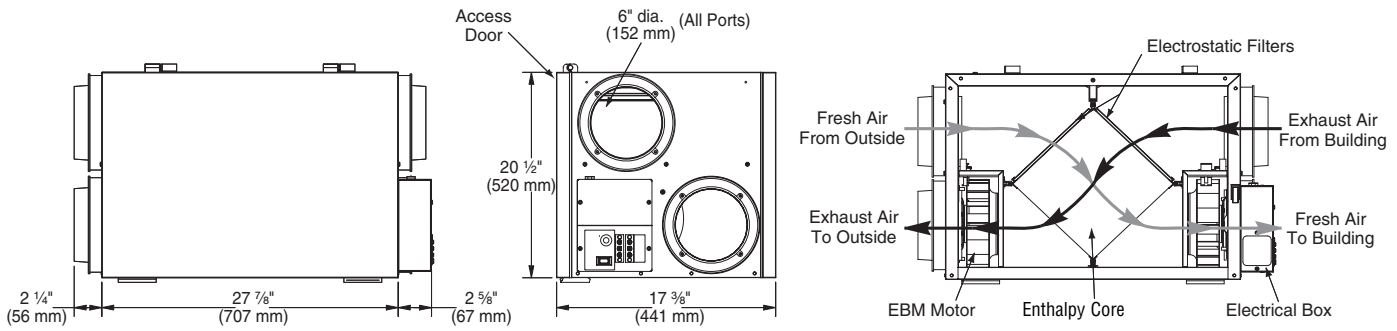

Ventilation Performance

EXT. STATIC PRESSURE		NET SUPPLY AIR FLOW		GROSS AIR FLOW SUPPLY				EXHAUST	
Pa	in wg	L/s	cfm	L/s	cfm	L/s	cfm	L/s	cfm
25	0.1	88	186	88	186	88	186	88	186
50	0.2	83	176	83	176	83	176	83	176
75	0.3	78	166	78	166	78	166	78	166
100	0.4	73	155	73	155	73	155	73	155
125	0.5	68	145	68	145	68	145	68	145
150	0.6	63	134	63	134	63	134	63	134
175	0.7	58	123	58	123	58	123	58	123
200	0.8	53	112	53	112	53	112	53	112
225	0.9	48	101	48	101	48	101	48	101
250	1.0	42	90	42	90	42	90	42	90

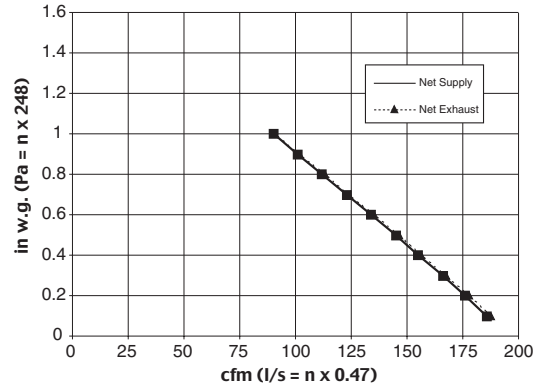

Energy Performance

	SUPPLY TEMPERATURE		NET AIRFLOW		POWER CONSUMED WATTS	SENSIBLE RECOVERY EFFICIENCY	APPARENT SENSIBLE EFFECTIVENESS	NET MOISTURE TRANSFER
	°C	°F	L/s	cfm				
Heating	0	32	30	64	62	81%	92%	0.78
	0	32	55	117	128	74%	86%	0.76
	0	32	76	161	194	70%	84%	0.71
							Total Recovery Efficiency	
Cooling	35	95	30	64	57	52%		
	35	95	55	117	130	46%		

Specifications and Ratings

- Model: SER 2004N
- Total assembled weight: 61 lbs
- Cabinet: 22 ga. steel w/ powder coat finish
- Motors: ebm motor w/backward curved blades
- Filters: 2 washable electrostatic filters
- Insulated with 1" (25 mm) high density polystyrene foam to prevent condensation and meet the requirements of the Underwriters Laboratories 94HF.
- Core: Enthalpy
- Supply & exhaust ducts: 6" (152.4mm)
- Mounting: Suspended by chains & hooks
- Electrical requirements:

Volts	Frequency	Amps	Watts	High Speed
120V	60Hz	1.9A	150W	
- 3' plug-in power cord w/ 3-prong plug

Contacts

Submitted by: _____ Date: _____

Qty: _____ Model #: _____

Comments: _____

Project #: _____

Location: _____

Architect: _____

Engineer: _____

Contractor: _____



United States

1712 Northgate Blvd.
 Sarasota, FL. 34234
 Phone: 800.747.1762; 941.309.6000
 Fax: 800.487.9915; 941.309.6099
 www.fantech.net
 info@fantech.net

Canada

50 Kanalfakt Way
 Bouctouche, NB E4S 3M5
 Phone: 800.565.3548; 506.743.9500
 Fax: 877.747.8116; 506.743.9600
 www.fantech.ca
 info@fantech.ca

Article #: 301XXX
 Rev Date: 110104



Fantech

Energy Recovery Ventilator

SER Series

SER 3204D

SPECIFICATIONS



FEATURES

- Compact design
- Backward curved impellers
- Electrostatic filters (washable)
- Enthalpy energy recovery core
- External screw type dry contacts for optional controls
- Improved core guide channels for easy removal of core

OPTIONAL CONTROLS

- EDF 5 – Digital multi-function wall control with cycle timer
- EDF 2 – Digital multi-function wall control
- MDEH 2 – Mechanical low voltage dehumidistat with On/Off switch
- MDEH 1 – Mechanical low voltage dehumidistat
- RTS 2 – 15 Minute pushbutton timer
- FD 30M – 30 Minute crank timer
- AQS 1 – Air quality sensor

WARRANTY

- 7 year on motors
- 5 year on parts
- 5 year on core (limited)

CASE 22 gauge galvanized steel. Baked powder coated paint, antique white. Insulated with 1" (25 mm) high density polystyrene foam to prevent condensation and meet the requirements of the Underwriters Laboratories 94HF.

MOTORS Four (4) German-engineered, factory-balanced ebm™ motors with backward curved blades. Motors come with permanently lubricated sealed ball bearings guarantee long life and maintenance-free operation. Seven (7) year warranty.

CORES Two (2) enthalpy energy recovery cores configured for an efficient cross-flow ventilation. Cores are 12" x 12" (305 x 305 mm) with a 11.34" (288 mm) depth. Cores are manufactured to withstand extreme temperature variations and material is Flame-proof paper and polyester-based synthetic paper.

FILTERS Four (4) Washable Electrostatic Panel Type Air Filters, they are 11.75" (298mm) x 11.4" (290mm) x 0.125" (3mm).

CONTROLS External three (3) position (Low/Stand By/Medium) rocker switch that will offer continuous ventilation. Fantech offers a variety of external controls. (see optional controls)

DEFROST During the defrost sequence, the supply blower shuts down and the exhaust blower switches into high speed to maximize the effectiveness of the defrost strategy.

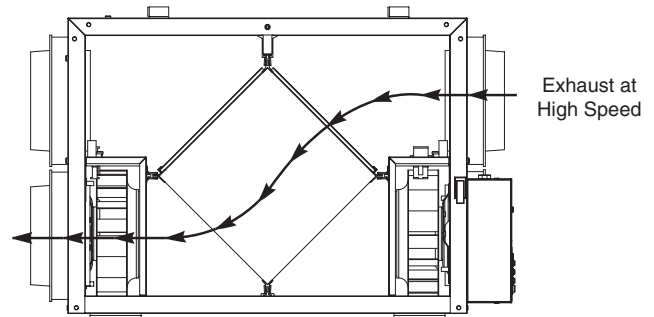

INSTALLATION Unit is typically hung by using installation kit supplied with unit. Mounting bolts provided on top four (4) corners of unit.

SERVICEABILITY Cores, filters, motors and drain pan can be easily serviced through latched access doors located on 2 sides of the unit. Cores conveniently slides out with ease on an improved railing system. Electrical box, placed on the outside of the unit, can also be easily accessed.

Distributed by:

Fantech, reserves the right to modify, at any time and without notice, any or all of its products' features, designs, components and specifications to maintain their technological leadership position.

Dimensions & Airflow - All units feature three foot plug-in power cord with 3-prong plug on top of electrical box.

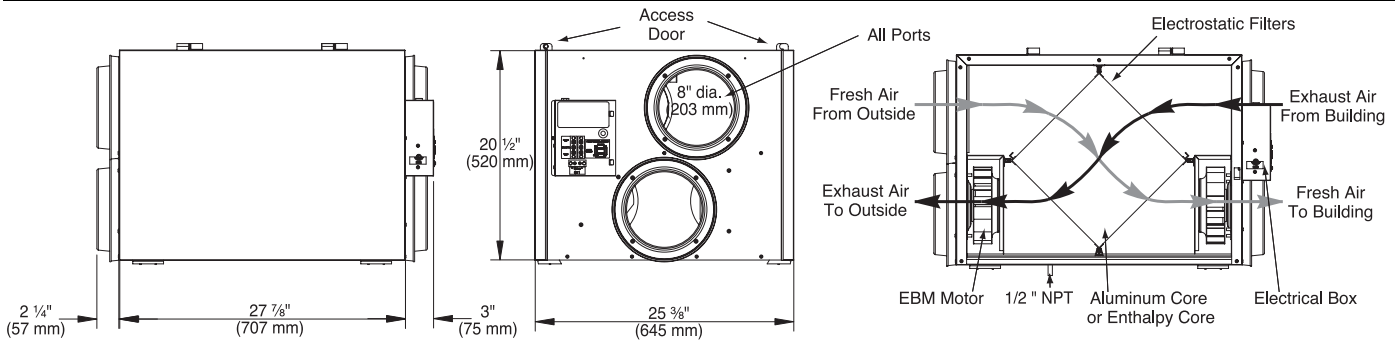

Ventilation Performance

EXT. STATIC PRESSURE		NET SUPPLY AIR FLOW		GROSS AIR FLOW SUPPLY			
Pa	in wg	L/s	cfm	L/s	cfm	L/s	cfm
25	0.1	126	268	131	277	139	294
50	0.2	124	262	127	270	132	279
75	0.3	116	246	119	253	126	266
100	0.4	109	231	112	238	117	247
125	0.5	103	219	107	226	111	236
150	0.6	96	204	100	211	101	215
175	0.7	93	196	95	202	101	213
200	0.8	89	188	92	194	94	200
250	1.0	77	163	79	168	82	174
300	1.2	69	147	71	151	71	151
350	1.4	56	118	57	121	58	123

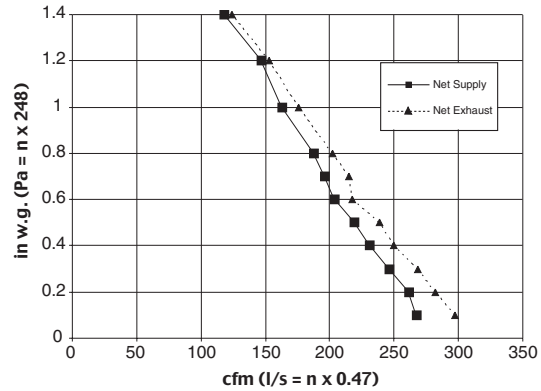

Energy Performance

	SUPPLY TEMPERATURE		NET AIRFLOW		POWER CONSUMED WATTS	SENSIBLE RECOVERY EFFICIENCY	APPARENT SENSIBLE EFFECTIVENESS	LATENT RECOVERY/MOISTURE TRANSFER
	°C	°F	L/s	cfm				
Heating	0	32	30	64	126	76	91	0.78
	0	32	55	117	212	78	92	0.76
	0	32	74	157	262	78	91	0.71
Total Recovery Efficiency								
Cooling	35	95	54	115	206	48 %		
	35	95	74	159	260	48 %		

Specifications and Ratings

- Model: SER 3204D (2 access doors)
- Total assembled weight: 80 lbs
- Cabinet: 22 ga. steel w/ powder coat finish
- Motors: ebm motor w/backward curved blades
- Filters: 4 washable electrostatic filters 11.75" (298mm) x 11.4" (290mm) x 0.125" (3mm)
- Insulated with 1" (25 mm) high density polystyrene foam to prevent condensation and meet the requirements of the Underwriters Laboratories 94HF.
- Two (2) cores: Enthalpy 12" (305mm) x 12" (305 mm) x 11.4" (288 mm)
- Supply & exhaust ducts: 8" (200 mm)
- Mounting: Suspended by chains & hooks
- Electrical requirements:

Volts	Frequency	Amps	Watts	High
120V	60Hz	2.5A	300W	Speed
- 3' plug-in power cord w/ 3-prong plug

Contacts

Submitted by: _____ Date: _____

Qty: _____ Model #: _____

Comments: _____

Project #: _____

Location: _____

Architect: _____

Engineer: _____

Contractor: _____



United States
 1712 Northgate Blvd.
 Sarasota, FL. 34234
 Phone: 800.747.1762; 941.309.6000
 Fax: 800.487.9915; 941.309.6099
 www.fantech.net
 info@fantech.net

Canada
 50 Kanaflikt Way
 Bouctouche, NB E4S 3M5
 Phone: 800.565.3548; 506.743.9500
 Fax: 877.747.8116; 506.743.9600
 www.fantech.ca
 info@fantech.ca

Article #: 301XXX
 Rev Date: 110104



Fantech

Energy Recovery Ventilator

SER Series

SER 3204N



SPECIFICATIONS

CASE 22 gauge galvanized steel. Baked powder coated paint, antique white. Insulated with 1" (25 mm) high density polystyrene foam to prevent condensation and meet the requirements of the Underwriters Laboratories 94HF.

MOTORS Four (4) German-engineered, factory-balanced ebm™ motors with backward curved blades. Motors come with permanently lubricated sealed ball bearings guarantee long life and maintenance-free operation. Seven (7) year warranty.

CORES Two (2) enthalpy energy recovery cores configured for an efficient cross-flow ventilation. Cores are 12" x 12" (305 x 305 mm) with a 11.34" (288 mm) depth. Cores are manufactured to withstand extreme temperature variations and material is Flame-proof paper and polyester-based synthetic paper.

FILTERS Four (4) Washable Electrostatic Panel Type Air Filters, they are 11.75" (298mm) x 11.4" (290mm) x 0.125" (3mm).

PORT SELECTION (Reversing Unit) Units are shipped indicating airflow (see "Dimensions & Airflow" on next page). These ports can be selected on site by the installer and changed around as needed. IE "Exhaust Air From Building" could be changed to "Air From Outside" and "Exhaust To Outside" switched to "Air To Building". The same is true for the other ports. This gives the installer greater flexibility in placement of the unit and ductwork.

SERVICEABILITY Cores, filters and motors can be easily serviced through latched access door. Cores conveniently slides out with ease on an improved railing system. Electrical box, placed on the outside of the unit, can also be easily accessed.

NOTE This model is not recommended for climates that experience temperatures below 23°F (-5°C) for more than 2 consecutive days.

FEATURES

- Compact design
- Backward curved impellers
- Electrostatic filters (washable)
- Enthalpy energy recovery core
- External screw type dry contacts for optional controls
- Improved core guide channels for easy removal of core

OPTIONAL CONTROLS

- EDF 5 – Digital multi-function wall control with cycle timer
- EDF 2 – Digital multi-function wall control
- RTS 2 – 15 Minute pushbutton timer
- FD 30M – 30 Minute crank timer
- AQS 1 – Air quality sensor

WARRANTY

- 7 year on motors
- 5 year on parts
- 5 year on core (limited)

Distributed by:

Dimensions & Airflow - All units feature three foot plug-in power cord with 3-prong plug on top of electrical box.

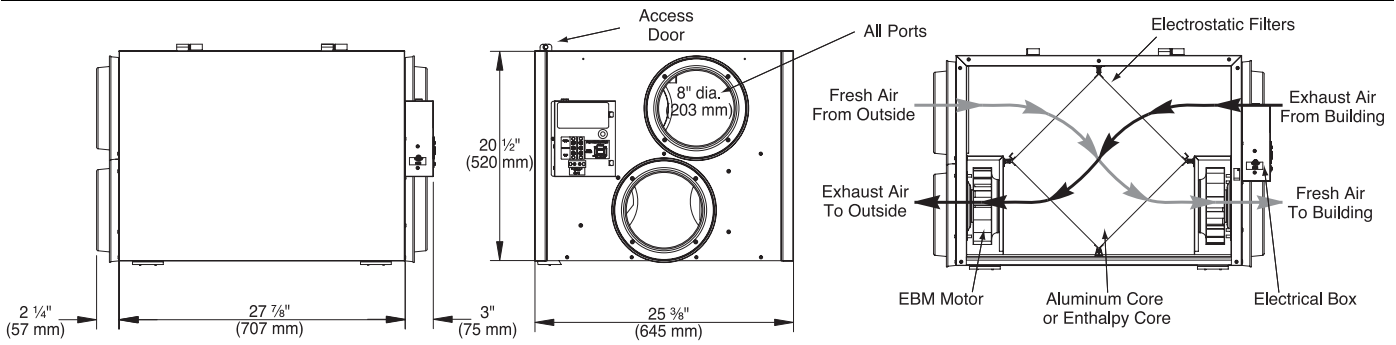

Ventilation Performance

EXT. STATIC PRESSURE		NET SUPPLY AIR FLOW		GROSS AIR FLOW SUPPLY			
Pa	in wg	L/s	cfm	L/s	cfm	L/s	cfm
25	0.1	126	268	131	277	139	294
50	0.2	124	262	127	270	132	279
75	0.3	116	246	119	253	126	266
100	0.4	109	231	112	238	117	247
125	0.5	103	219	107	226	111	236
150	0.6	96	204	100	211	101	215
175	0.7	93	196	95	202	101	213
200	0.8	89	188	92	194	94	200
250	1.0	77	163	79	168	82	174
300	1.2	69	147	71	151	71	151
350	1.4	56	118	57	121	58	123

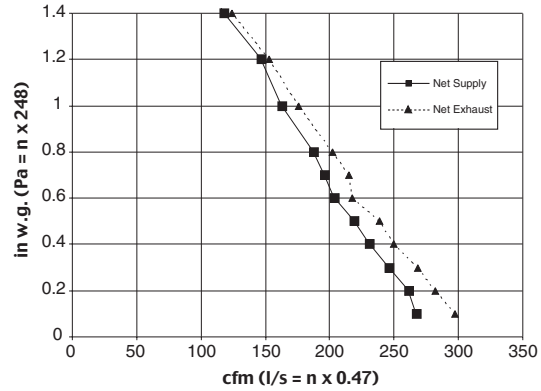

Energy Performance

	SUPPLY TEMPERATURE		NET AIRFLOW		POWER CONSUMED WATTS	SENSIBLE RECOVERY EFFICIENCY	APPARENT SENSIBLE EFFECTIVENESS	LATENT RECOVERY/MOISTURE TRANSFER
	°C	°F	L/s	cfm				
Heating	0	32	30	64	126	76	91	0.78
	0	32	55	117	212	78	92	0.76
	0	32	74	157	262	78	91	0.71
Total Recovery Efficiency								
Cooling	35	95	54	115	206	48 %		
	35	95	74	159	260	48 %		

Specifications and Ratings

- Model: SER 3204N
- Total assembled weight: 80 lbs
- Cabinet: 22 ga. steel w/ powder coat finish
- Motors: ebm motor w/backward curved blades
- Filters: 4 washable electrostatic filters
11.75" (298mm) x 11.4" (290mm) x 0.125" (3mm)
- Insulated with 1" (25 mm) high density polystyrene foam to prevent condensation and meet the requirements of the Underwriters Laboratories 94HF.
- Two (2) cores: Enthalpy
12" (305mm) x 12" (305 mm) x 11.4" (288 mm)
- Supply & exhaust ducts: 8" (200 mm)
- Mounting: Suspended by chains & hooks
- Electrical requirements:
Volts Frequency Amps Watts High Speed
120V 60Hz 2.5A 300W
3' plug-in power cord w/ 3-prong plug

Contacts

Submitted by: _____ Date: _____

Qty: _____ Model #: _____

Comments: _____

Project #: _____

Location: _____

Architect: _____

Engineer: _____

Contractor: _____



Fantech

United States

1712 Northgate Blvd.
Sarasota, FL. 34234
Phone: 800.747.1762; 941.309.6000
Fax: 800.487.9915; 941.309.6099
www.fantech.net
info@fantech.net

Canada

50 Kanalfakt Way
Boucouteche, NB E4S 3M5
Phone: 800.565.3548; 506.743.9500
Fax: 877.747.8116; 506.743.9600
www.fantech.ca
info@fantech.ca

Article #: 301XXX
Rev Date: 110104

OPERATION

An Energy Recovery Ventilator (ERV) is designed to bring in fresh air into the building while exhausting an equal amount of stale air. During colder months, utilizing the heat recovered from the stale air before it is exhausted outdoors warms the cold fresh air. At the same time, humidity contained indoors is transferred back to the incoming fresh and dried air.

During warm and humid months, the ERV will cool the incoming outdoor air by using the cool air-conditioned air that is being exhausted from indoors while allowing the humidity contained in the fresh air to be transferred to the exhaust air.

Fantech ERV's are designed to run continuous or on intermittent, giving the homeowner complete control over their air quality. Continuous low speed ventilation is recommended, which will help eliminate carbon dioxide, voc's and other gases as well as freshen up the home. Intermittent high speed ventilation can be obtained through a variety of optional remote controls found in this manual.

MODES OF OPERATION

The entire line of SER series Energy Recovery Ventilators comes equipped with Fantech's new electronic uni-control board which offers a wide variety of features making it the ultimate ventilation control system. Fantech engineers have used the latest technology to provide solid, trouble free operation under any conditions.

The Fantech uni-control board offers stand alone operating capabilities as well as an exclusive 2 wire communication to most external controls. The trouble-free optional controls include: two different rotary dial dehumidistats, an air quality sensor (3 wire communication required), a 15 minute remote push-button timer, as well as the most sophisticated line of remote wall mounted controls, the Intellitek EDF5 (5MR).

An on-board diagnostic LED helps find problems quickly and efficiently. For example the LED can be used to signal a broken or shorted electronic wall control wire. Electronic air temperature probe gives this board accurate readings in order to minimize unnecessary defrost operation, and the on-board jumpers provide the user with the option of adjusting defrost time and sequence to optimize performance under abnormal conditions. The defrost operation is automatic and is usually never adjusted.

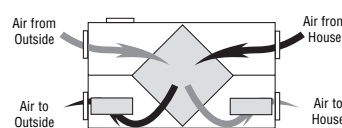

1. Continuous / Ventilation Mode
In this mode of operation both fans are operating and exchanging air with the outside. The energy recovery ventilator (ERV) constantly exchanges the air at the rate you select, either at low or medium speed, and switches to high speed when activated by an optional remote control. The "Low" and "Med" fan speed selection will cause the unit to operate in continuous exchange mode at an exchange rate of 35% and 50% maximum airflow rating respectively. Continuous mode is recommended, since pollutants are slowly but constantly being generated in your house.

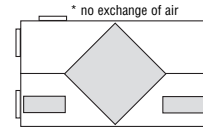

2. Intermittent / Standby Mode
The system is always on standby and operates at high speed when activated by an optional remote control. "Standby" should be selected if the user wishes to stop the unit from continuous exchange. We recommend that the "Standby" mode only be used if your system is equipped with an optional external control, in which case, the unit would activate to "High" fan speed, until the control is satisfied and then return to standby (off).

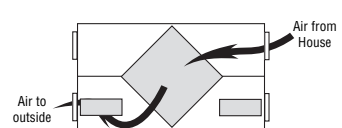

3. Defrost (on selected models)
The automatic defrost cycle consists of a fan shutdown. When the supply air stream temperature goes below -5°C (23°F), the supply motor shuts down and the exhaust motor goes into high speed. Ambient air is passed through the unit for a period of 5 minutes. The supply motor will then re-start and run at the preset speed. The exhaust motor will also slow down to the preset speed, and the unit will operate in the run cycle for 25 minutes. This fan shutdown defrost cycle continues until the supply air stream rises above 0°C (32°F).

OPERATION (CONT'D)

PRACTICAL TIPS

To avoid window condensation:

- If a dehumidistat or EDF control is installed, the humidity setting should be raised to its highest setting (e.g. 99% on EDF) when using an ERV during warm and humid months. Otherwise, the ERV may stay on HIGH speed, bringing in more humid air indoors.



NOTE:

A dehumidistat is ideal for use in energy efficient houses where indoor humidity (during the heating season) is higher than outdoor levels. High humidity is a major cause of structure damage and IAQ problems such as mold and mildew.

PRACTICAL TIPS

NOTE:

When an Intellitek control is installed, the rocker switch located on the right hand side of the ERV will be automatically deactivated giving the user complete control from wherever he/she wishes to mount the control pad.

NOTE:

The override speed cannot be set at a fan speed lower or equal to the normal operating fan speed. For example, if the unit is normally operating at a medium fan speed, the override fan speed will be automatically set to high.

NOTE:

EDF5 model, changing the override speed will change default override speed for other external controls.

EXAMPLES:

If on the EDF5 control, you have set the override control at medium, and you start an external remote control (15 min. timer), the unit will run at medium fan speed for 15 min.

OPTIONAL REMOTE CONTROLS

* All controls are low voltage. 18 to 24 gauge wire is recommended.



2 wire installation

Dehumidistat I - The wall mount dehumidistat monitors the humidity level in the area it is installed. When the humidity level rises above the desired set-point, the ERV will activate to high speed/override mode. Once the humidity level returns to desired condition, the unit will return to the normal mode.



4 wire installation

Dehumidistat II - The wall mount dehumidistat II offers the same features of the dehumidistat I plus additional off/on control for the ERV. Dial illuminates when in override mode.



3 wire installation

Air Quality Sensor - The wall mount Air Quality Sensor (AQS) monitors indoor air quality and activates the override mode when carbon monoxide, formaldehyde, benzene, volatile organic compounds and other pollutants are detected. The unit will then return to normal mode once the air pollutants are reduced to a pre-determined lower level.

* This control is not a warning device.



2 wire installation

15-min Timer - The 15-minute remote timer is typically installed in areas where contamination such as moisture and odors, are produced. Simply push the button and the ERV will activate to high speed for 15 minutes. Up to 5 electronic timers can be installed in parallel throughout the building at a distance of up to 500 feet (152 meters) from the ERV.

OPTIONAL INTELLITEK CONTROL

• All controls are low voltage. 18 to 24 gauge wire is recommended.

DIGITAL HYGROMETER DISPLAY

Shows Indoor Humidity Level

OVERRIDE TIMER

When pressed, unit will provide high speed ventilation for one 15, 30 or 60 minute period.

MAINTENANCE LIGHT

Light comes on when it's time to clean unit.

POWER

On/Off and Reset

MODES

Select Intermittent or Continuous Ventilation Modes



DEHUMIDISTAT CONTROL (see description)

EDF5 INTELLITEK MULTI-FUNCTION WALL CONTROL

Control multiple functions of your Fantech ERV with one slimline wall control. Two wire connection simplifies installation. Use one EDF5 per ERV installed.

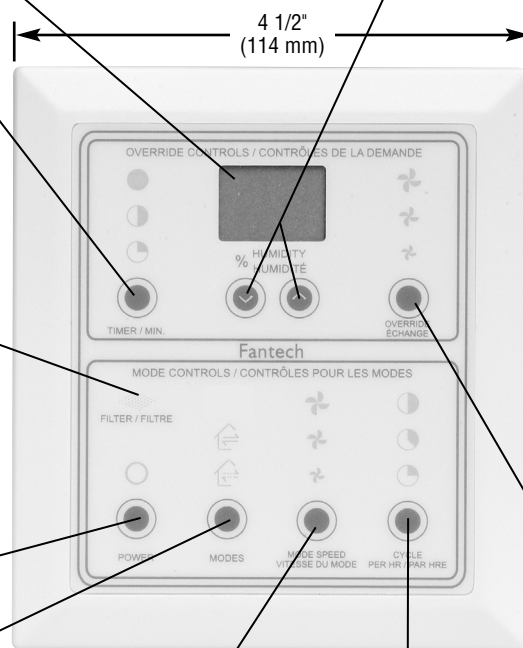

5 1/8" (130 mm)

Width = 4 1/2" (114mm)
Height = 5 1/8" (130mm)
Thickness = 5/8" (16mm)

OVERRIDE SPEED CONTROL

Push to select override speed of unit. (High Speed Recommended)

OPERATION (CONT'D)

OPTIONAL INTELLITEK CONTROL

DIGITAL HYGROMETER DISPLAY
Shows Indoor Humidity Level
This control will not read below
29% RH

OVERRIDE TIMER
When pressed, unit will provide high speed ventilation for 15 minute period. Once the time elapsed the unit will return to its normal function. To move from one time to the other, continue pressing the timer button until you reach the desired time.

POWER
On/Off
This function is to turn your unit on or off. To go from the on to off position just press once.

DEHUMIDISTAT CONTROL
A Dehumidistat is ideal for use in energy efficient houses where indoor humidity (during the heating season) is higher than outdoor levels. High humidity is a major cause of structure damage and IAQ problems such as mold and mildew. This feature can be turned off when installed in climates that do not require it.

The LCD (Liquid Crystal Display) indicates the percentage of Relative Humidity in the air surrounding the control and ultimately in the house. Pressing either of the setpoint selectors (▼, ▲) once, will display the desired RH level. The setpoint selection mode is now activated and can be adjusted with either selectors to a newly desired setpoint. The LCD will return to the actual RH level display after a few seconds.

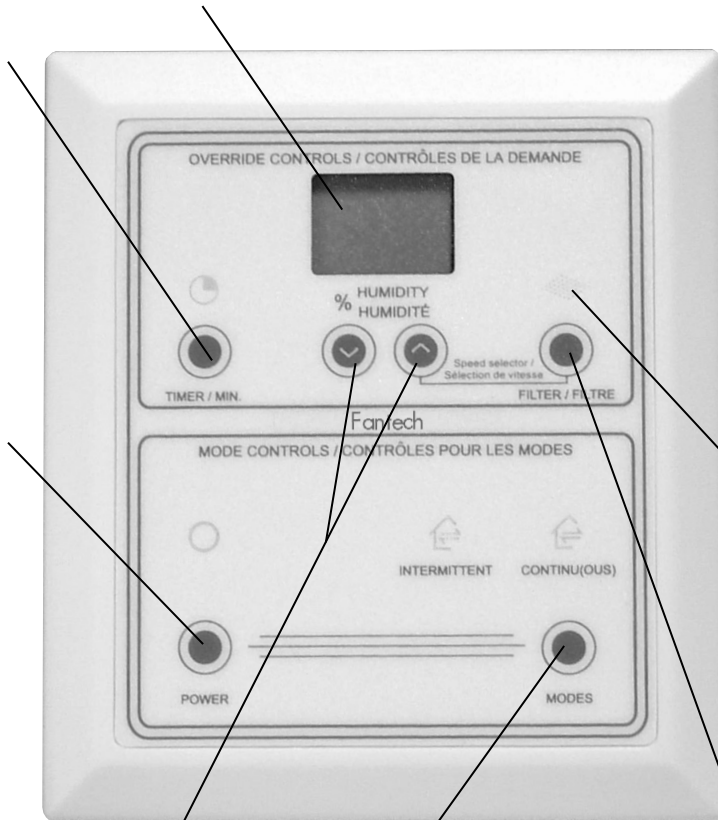

EDF2 INTELLITEK MULTI- FUNCTION WALL CONTROL

Control multiple functions of your Fantech SER with one slimline wall control. Two wire connection simplifies installation. Use one 2M per SER installed.

MAINTENANCE LIGHT
When the light is on it indicates it may be time to clean unit. To reset the light, after cleaning the filters, just push the power button and restart the unit. This will turn the light off and reset the clock for your filter check.

MODES
Select Intermittent, or Continuous Ventilation Modes.

Continuous
This function will exchange outside air with your stale air.

Intermittent
This function will put your unit on stand by and can be over ride by timer, air quality sensor, etc

To move from function to the other, continue pressing the mode button until you reach the desired function. This function goes from Continuous to Intermittent.

FILTER LIGHT RESET & MODE FAN SPEED SELECTOR
Press to reset the filter maintenance reminder light. The combination filter light reset and up setpoint selector buttons (▲) let's you choose at which speed the HRV, ERV unit will operate at. Pressing the filter light reset button once displays the mode fan speed on the LCD. The LCD should display one of the following three letters, L for Low, M for Medium and H for High. To change the mode speed, press the up setpoint (▲) until desired speed is displayed, selector. After 1 second of inactivity, the LCD will return to relative humidity reading.

Note: All controls are low voltage. 18 to 24 gauge wire is recommended.

INSTALLATION

PRACTICAL TIPS

- Install the unit close to the outside wall on which the supply and exhaust hoods will be mounted.
 - Have a nearby power supply 120 Volts, 60Hz.
 - Have the possibility of mounting the unit to supporting beams.
 - Mount the unit as level as possible in order to allow proper condensate drainage.
 - For units that have defrost access to a water drain for the condensate of the unit is required.
 - Minimize any noise level that would be created by the unit in the living area.
 - Have access for future maintenance.
- * Note: Unit may also be placed on a platform, however 3" clearance on bottom is still required for drain (where applicable) and to open access latches.

LOCATION

The ERV should be located in a conditioned space where it will be possible to conveniently service the unit. Typically the ERV would be located in the mechanical room or an area close to the outside wall where the weatherhoods will be mounted.

Connecting appliances to the ERV It is not recommended, including:

- clothes dryer
- range top
- stovetop fan
- central vacuum system

These appliance may cause lint, dust or grease to collect in the ERV, damaging the unit.

NOTE: Connecting any of these type of appliances to the ERV will "void" your warranty

MOUNTING *



1 Place Fastening hooks on the strapping board or the floor joists.

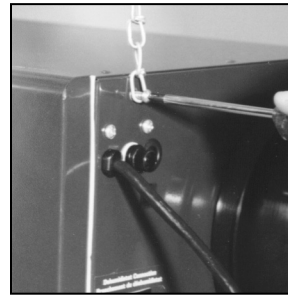

2 Attach a hanging chain (provided) to each 10 3/4" (19 mm) bolt (provided) in the top 4 corners of the unit and tighten.

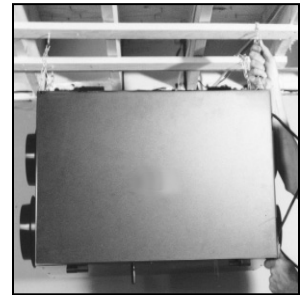

3 Hang the unit by slipping a link onto the hanging hooks, making sure the unit is level.

Installing Drain Line - Units with defrost

Through normal operation and during its defrost mode, the ERV may produce some condensation. This water should flow into a nearby drain, or be taken away by a condensate pump. The ERV and all condensate lines must be installed in a space where the temperature is maintained above the freezing point. A "P" trap should be made in the drain line. This will prevent odors from being drawn back up into the unit.

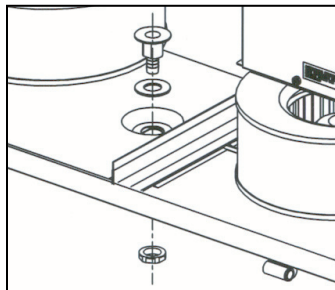

1 Install the drain nipple.



2 Install the drain hose, making a "P" trap

INSTALLING DUCTS GOING TO / FROM OUTSIDE

PRACTICAL TIPS

- Decide where your intake and exhaust hoods will be located.

Locating the Intake Weatherhood

- Should be located upstream (if there are prevailing winds) from the exhaust outlet
- At least 4' - 6' (2m) from the exhaust weatherhood
- At least 6' (2m) away from dryer vents and furnace exhaust (medium or high efficiency furnaces)
- A minimum of at least 6' (2m) from driveways, oil fill pipes, gas meters, or garbage containers
- At least 18" (457mm) above the ground
- At least 3' (1m) from the corner of the building
- Do not locate in a garage, attic or crawl space

Locating the Exhaust Weatherhood

- At least 6' (2m) from the ventilation air intake
- At least 18" (457mm) above ground
- At least 3' (1m) away from the corner of the building
- Not near a gas meter, electric meter or a walkway where fog or ice could create a hazard
- Not into a garage, workshop or other unheated space

When installing the weatherhood, its outside perimeter must be sealed with exterior caulking.

A well designed and installed ducting system will allow the ERV to operate at its maximum efficiency. Always try to keep duct runs as short and straight as possible.

See Installation Diagrams for installation examples.

INSTALLING THE DUCTING TO THE WEATHERHOODS

The inner liner of the flexible insulated duct must be clamped to the sleeve of the weatherhoods (as close to the outside as possible) and to the appropriate port on the ERV. The insulation should remain full and not be squished. The outer liner, which acts as a vapor barrier must be completely sealed to outer wall and the ERV using tape and or caulking. A good bead of high quality caulking (preferably acoustical sealant) will seal the inner flexible duct to both the ERV port and the weatherhood prior to clamping. To minimize air flow restriction, the flexible insulated duct that connects the two outside weatherhoods to the ERV should be stretched tightly and be as short as possible. Twisting or folding the duct will severely restrict air flow.

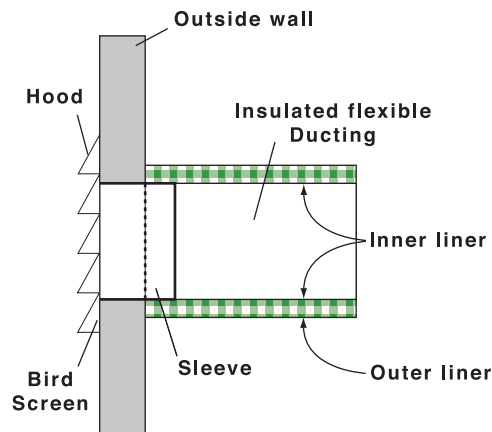

Model	Description
FML 8*	8" White Fixed Metal Hoods
COM 6P	Supply & Exhaust Plastic Hood Kit
COM 6M	Supply & Exhaust Metal Hood Kit

* Application for Supply or Exhaust



1 Using the collar of the outside hood, outline the intake & exhaust holes to be cut. The holes should be slightly larger than the collar to allow for the thickness of the insulated flexible duct. Cut a hole for both the intake and exhaust hoods.



2 Pull the insulated flexible duct through the opening until it is well extended and straight. Slide the duct's inner vinyl sleeve over the hood collar and secure, pull the insulation over the duct and then the vapor barrier over the sleeve and secure with duct tape.



3 Push the hood into the opening. Attach the hood to the outside wall with mounting screws. Repeat the installation procedure for both the Supply and Exhaust hood.



4 Using a caulking gun, seal around both hoods to prevent any leaks.

INSTALLING DUCTS TO / FROM INSIDE

To maximize airflow in the ductwork system, all ducts should be kept short and have as few bends or elbows as possible. Forty-five degree are preferred to 90° elbows. Use “Y” tees instead of 90° elbows whenever possible.

All duct joints must be fastened with screws or duct sealant and wrapped with a quality duct tape to prevent leakage. Aluminum foil duct tape is recommended. Galvanized ducting from the ERV to the living areas in the house is recommended whenever possible, although flexible duct can be used in moderation when necessary.

SUPPLY AIR DUCTING

In homes without a forced air furnace, fresh air should be supplied to all habitable rooms including, bedrooms and living areas. It should be supplied from high wall or ceiling locations. Grills that diffuse the air comfortably such as Fantech grille (MGE (metal) or PGE (plastic))s are recommended. To avoid possible noise transfer through the ductwork system, a short length (approximately 12”, 300 mm) of nonmetallic flexible insulated duct should be connected between the ERV and the supply/exhaust ductwork system.

The main supply and return lines to/from the ERV should be sized to match the diameter of the port collar found on the ERV model chosen. Branch lines to the individual rooms may be as small as 4 inches (100 mm), but 5 inch (125 mm) lines are preferred. If the floor is the only option available, then special care should be taken in locating Grills. Areas such as under baseboard heaters will help to temper the air.

PRACTICAL TIPS

- Building Codes and Combustion Appliance Installation Codes do not allow location of return air Grills or any opening such as a “breathing tee” in an enclosed room with spillage susceptible combustion appliances.
- The fresh air inlet from the ERV needs to respect a minimum distance from the furnace return drop to ensure proper air mixing and temperature at the furnace core. See furnace manufacturer for appropriate specifications.

Direct Connection

- Should you wish to hard duct the supply air directly into the air duct return of the furnace or air handler, remember to check the airflow balance of the ERV with the furnace fan both “on” and “off” to determine that it does not imbalance the ERV more than 10%.

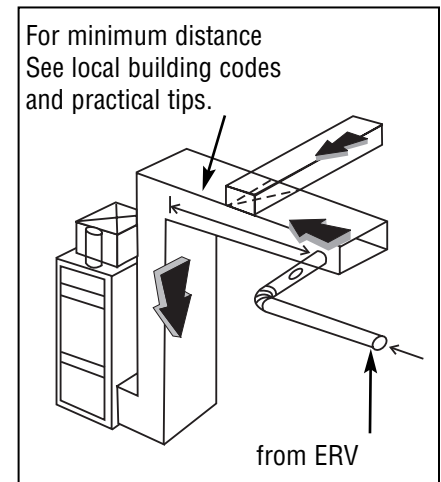

CAUTION: In humid climates, it may be "preferable" to have a dedicated ducting system to the house for the ERV instead of connecting the ERV to the central air-conditioner. Since the central air-conditioner fan must be running continuously to allow the fresh air from the ERV to be properly distributed throughout the house, it may pick up humidity from the cooling coil when it is not operating and re-distribute it to the house, causing excess humidity. This situation may be particularly aggravated if the air-conditioner is over-sized.

INSTALLING DUCTS TO / FROM INSIDE (CONT'D)

Exhaust Air Ducting

The stale air exhaust system is used to draw air from the points in the house where the worst air quality problems occur. It is recommended that return air ducts be installed in the bathroom, kitchen, and laundry room. The furnace or air handler return duct may be also used to exhaust from. In this method, the exhaust air is not ducted back from bathrooms, kitchens, etc to the ERV with “dedicated lines”.

PRACTICAL TIPS

- Choose the location for your Supply and Exhaust Grills - Fantech MGE (metal) or PGE (plastic). The Supply Grills should be located in every habitable room and the Exhaust Grills should be located in the wet rooms.
- A piece of flexible ducting should be placed between the Supply Air In and Out collar of the ERV and the rigid ducting to absorb any noise or vibrations.
- For proper network of ducting, see **TYPES OF INSTALLATIONS**.
- The Grills are to be installed on the ceiling or on the wall 6” (152 mm) to 12” (305 mm) from the ceiling.

Attic or Garage Installation

- 1** Begin with the duct collar marked “Exhaust Air In”. Slide a short piece (12”) of flexible duct over the duct collar. Using duct tape, tape the flexible duct to the collar. Run the flexible ducting to the main rigid duct trunk line, which connects to the remainder of the ducts going to and from rooms in the house. Repeat the steps for the “Supply Air Out” on the side of the ERV.
- 2** Working from a closet, attic or inside your joist wall, run the length of ducting required for the proper grille location and cut a hole in the drywall. Fasten the mounting collar (optional) to the ducting and fasten the collar to the wall or ceiling with screws.
- 3** The Fantech grill - MGE (metal) or PGE (plastic) - airflow can be adjusted by rotating the inside unit. It is recommended that the Grills be completely opened at first and then adjusted later as needed.
- 4** Push the Fantech grill - MGE (metal) or PGE (plastic) - into the optional mounting collar or directly into installed elbow.

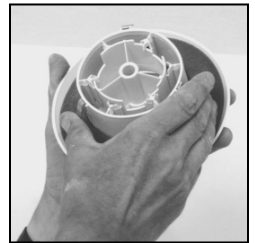
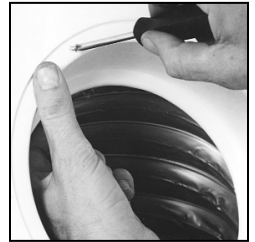

INSTALLATION EXAMPLES

It is the responsibility of the installer to ensure all ductwork is sized and installed as designed to ensure the system will perform as intended. All air movement devices have a performance curve. The amount of air (CFM) that an ERV will deliver is directly related to the total external static pressure (E.S.P.) of the system. Static pressure is a measure of resistance imposed on the blower by length of duct work/number of fittings used in duct work, duct heater etc.

Example diagram only-duct configuration may change depending on model

Fully Dedicated System (new construction)

Stale air drawn from key areas of home (bathroom, kitchen, laundry)

Fresh air supplied to main living areas

ERV must be balanced

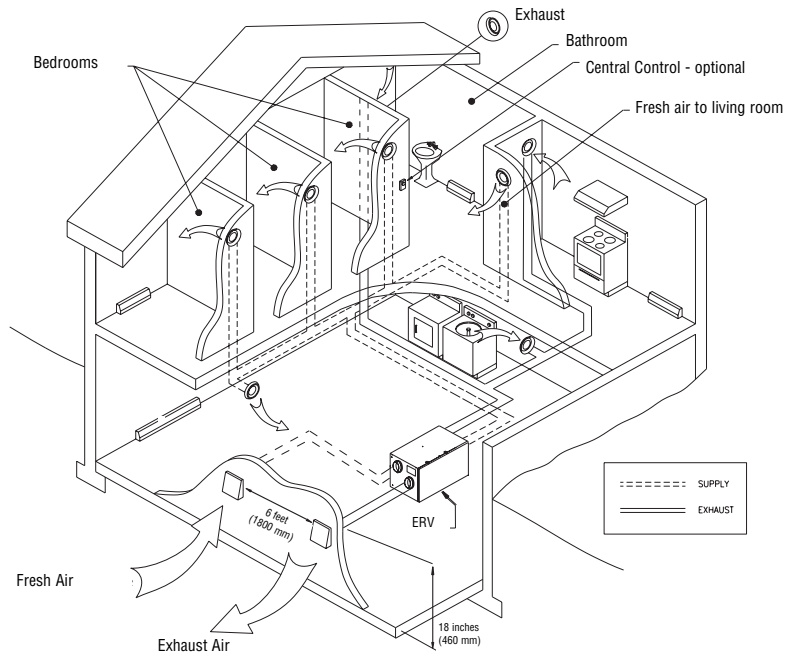

INSTALLATION EXAMPLES (CONT'D)

Example diagram only-duct configuration may change depending on model

DIRECT CONNECTION of the SUPPLY AIR STREAM to the FURNACE COLD AIR RETURN
(Stale air drawn from key areas of home)

Partially Dedicated System

Stale air drawn from key areas of home (bathroom, kitchen, laundry)

Fresh air supplied to main living areas via the forced air system.

ERV must be balanced

CAUTION

In very humid climates, it may be "preferable" to have a dedicated ducting system to the house for the ERV instead of connecting the ERV to the central air-conditioner. Since the central air-conditioner fan must be running continuously to allow the fresh air from the ERV to be properly distributed throughout the house, it may pick up humidity from the cooling coil when it is not operating and re-distribute it to the house, causing excess humidity. This situation may be particularly aggravated if the air-conditioner is over-sized.

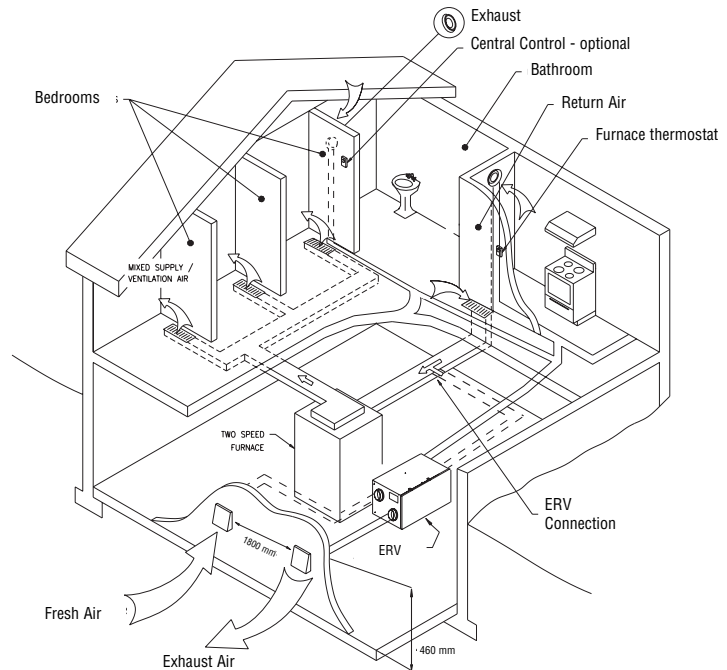

* Ducts connection may vary depending on model

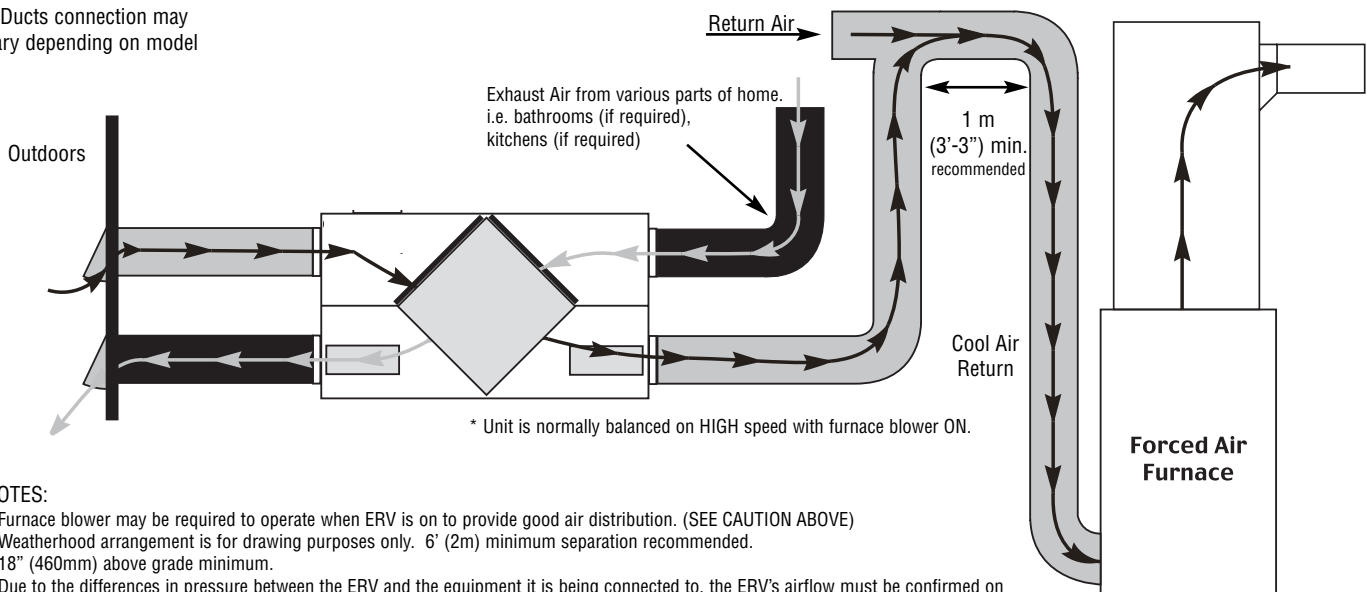

NOTES:

1. Furnace blower may be required to operate when ERV is on to provide good air distribution. (SEE CAUTION ABOVE)
2. Weatherhood arrangement is for drawing purposes only. 6' (2m) minimum separation recommended. 18" (460mm) above grade minimum.
3. Due to the differences in pressure between the ERV and the equipment it is being connected to, the ERV's airflow must be confirmed on site, using the balancing procedure found in the installation manual.

INSTALLATION EXAMPLES (CONT'D)

Example diagram only-duct configuration may change depending on model

DIRECT CONNECTION of both the ERV SUPPLY AIR STREAM and EXHAUST AIR STREAM to the FURNACE COLD AIR RETURN

Simplified Installation

Option 1 (Return/Return Method)

- ERV must be balanced
- ERV must be interlocked with the furnace blower
- Check local codes/authority having jurisdiction for acceptance

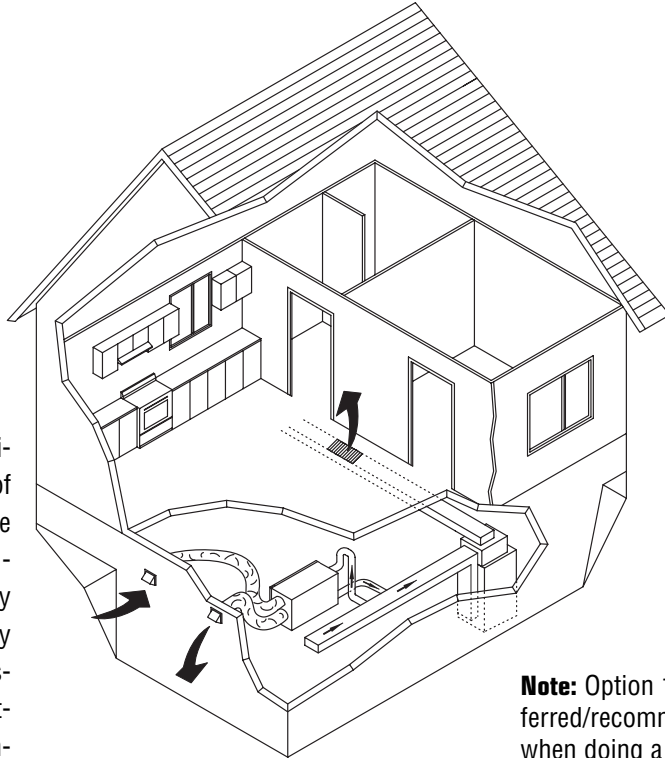

Note: Option 1 is the preferred/recommended method when doing a simplified installation

CAUTION

In humid climates, it may be "preferable" to have a dedicated ducting system to the house for the ERV instead of connecting the ERV to the central air-conditioner. Since the central air-conditioner fan must be running continuously to allow the fresh air from the ERV to be properly distributed throughout the house, it may pick up humidity from the cooling coil when it is not operating and re-distribute it to the house, causing excess humidity. This situation may be particularly aggravated if the air-conditioner is over-sized.

* Ducts connection may vary depending on model

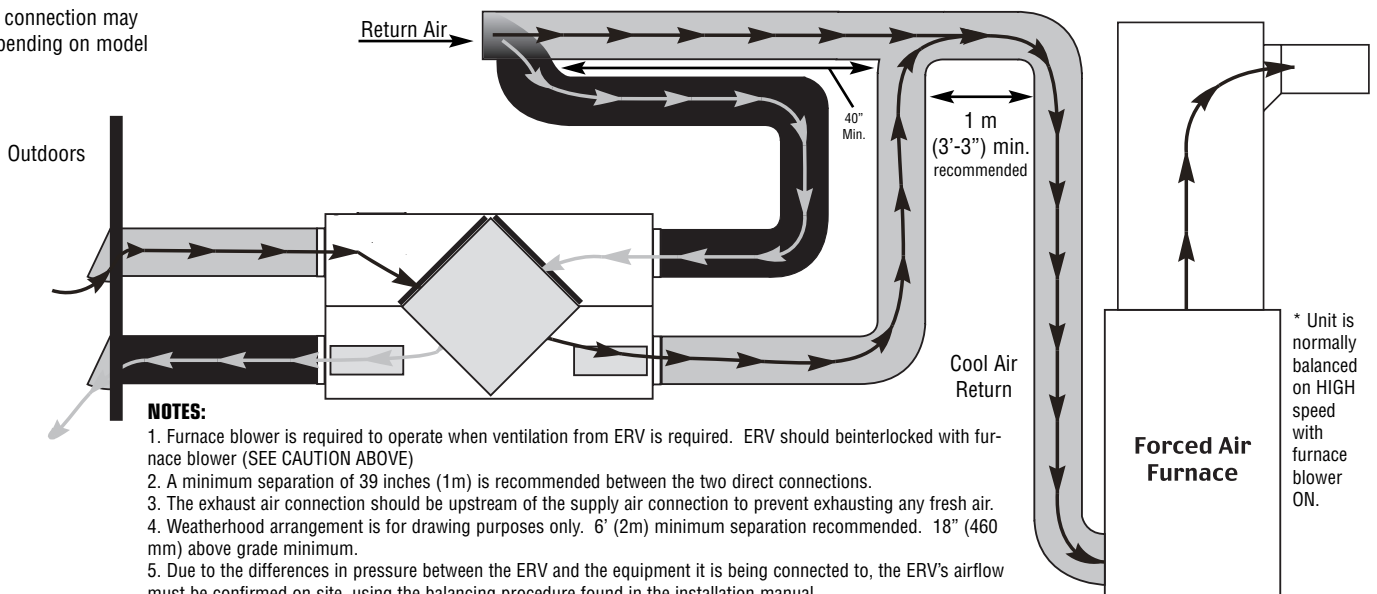

INSTALLATION EXAMPLES (CONT'D)

Example diagram only-duct configuration may change depending on model

DIRECT CONNECTION of both the ERV SUPPLY AIR STREAM & EXHAUST AIR STREAM to the FURNACE COLD AIR RETURN & SUPPLY AIR SIDE

Simplified Installation

Option 2 (Supply/Return Method)

- ERV must be balanced
- ERV must be interlocked with the furnace blower
- Check local codes /authority having jurisdiction for acceptance

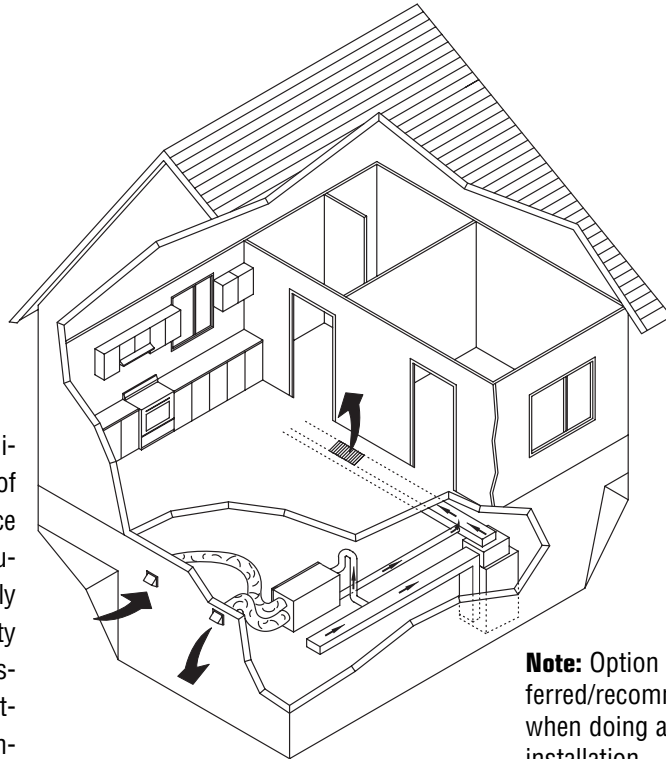

Note: Option 1 is the preferred/recommended method when doing a simplified installation

CAUTION

In humid climates, it may be "preferable" to have a dedicated ducting system to the house for the ERV instead of connecting the ERV to the central air-conditioner. Since the central air-conditioner fan must be running continuously to allow the fresh air from the ERV to be properly distributed throughout the house, it may pick up humidity from the cooling coil when it is not operating and re-distribute it to the house, causing excess humidity. This situation may be particularly aggravated if the air-conditioner is over-sized.

* Ducts connection may vary depending on model

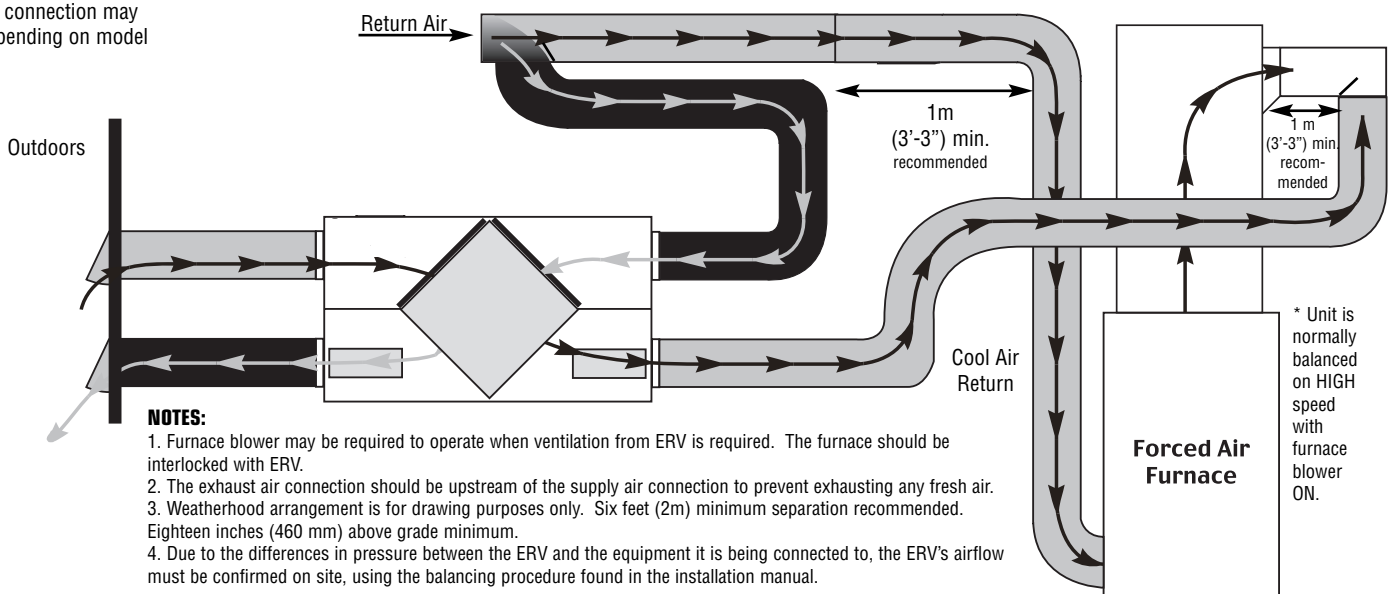

AIR FLOW BALANCING

CAUTION

- If the unit's airflows are not properly balanced...
 - The unit may not operate at its maximum efficiency.
 - Energy recovery core damage may occur.
 - The unit's use could cause negative or positive pressure in your home causing cold air to enter or other combustible equipment to backdraft.
 - The unit may not defrost properly.

PITOT TUBE BALANCING PROCEDURE

PITOT TUBE

BALANCING PROCEDURE

The following is a method of field balancing an ERV using a Pitot tube, advantageous in situations when flow stations are not installed in the ductwork. Procedure should be performed with the ERV on high speed.

The first step is to operate all mechanical systems on high speed, which have an influence on the ventilation system, i.e. the ERV itself and the forced air furnace or air handler if applicable. This will provide the maximum pressure that the ERV will need to overcome, and allow for a more accurate balance of the unit.

Drill a small hole in the duct (about 3/16), three feet downstream of any elbows or bends, and one foot upstream of any elbows or bends. These are recommended distances but the actual installation may limit the amount of straight duct.

The Pitot tube should be connected to a magnehelic gauge or other manometer capable of reading from 0 to 0.25 in. (0-62 Pa) of water, preferably to 3 digits of resolution. The tube coming out of the top of the pitot is connected to the high pressure side of the gauge. The tube coming out of the side of the pitot is connected to the low pressure or reference side of the gauge.

Insert the Pitot tube into the duct; pointing the tip into the airflow. For general balancing it is sufficient to move the pitot tube around in the duct and take an average or typical reading. Repeat this procedure in the other (supply or return) duct. Determine which duct has the highest airflow (highest reading on the gauge). Reduce this airflow using damper. The flows should now be balanced. Actual airflow can be determined from the gauge reading.

The value read on the gauge is called the velocity pressure. The Pitot tube comes with a chart that will give the air flow velocity based on the velocity pressure indicated by the gauge. This velocity will be in either feet per minute or meters per second. To determine the actual airflow, the velocity is multiplied by the cross sectional areas of the duct being measured.

This is an example for determining the airflow in a 6" duct. The Pitot tube reading was 0.025 inches of water.

From the chart, this is 640 feet per minute.

The 6" diameter (D) duct has cross sectional area (A) of

$$A = 3.14 \times (D/24)^2$$

$$A = 3.14 \times (6/24)^2$$

$$A = 0.196 \text{ or about } 0.2 \text{ ft}^2$$

The airflow is then: 640 ft/min x 0.2 ft² = 128 cfm

For your convenience, the cross sectional area of some common round duct is listed below:

DUCT DIAM. (inches)	CROSS SECTION AREA (sq ft.)
5	0.14
6	0.20
7	0.27
8	0.35

The accuracy of the airflow reading will be affected by how close to any elbows or bends the readings are taken. Accuracy can be increased by taking an average of multiple readings as outlined in the literature supplied with the Pitot tube.

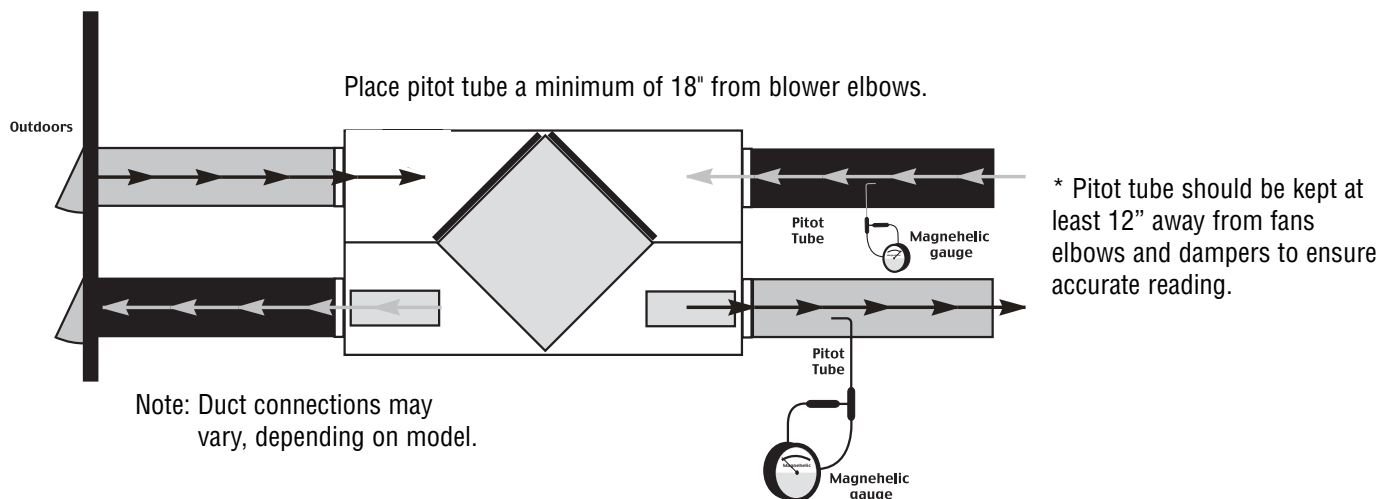

- The balancing procedure consists of measuring the exhaust air leaving the system and the supply air entering the system and ensuring that these two are equal. A deviation of 10% or less is acceptable.

AIR FLOW BALANCING (CONT'D)

AIRFLOW STATION (GRID) METHOD

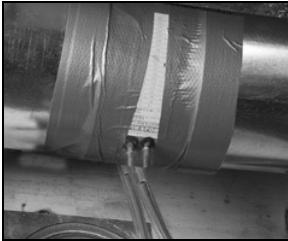

1 For this flow measuring station, cut the duct and place the flow measuring station between each station. Make sure that the flow measuring station's air direction arrow points in the direction of the airflow. Secure the flow measuring station with duct tape.

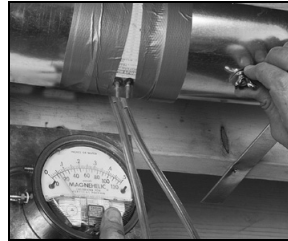

3 Adjust the damper until you reach the desired velocity.
(damper should be 18" from grid)



2 Before taking the reading, make sure that the magnehelic gauge is level and at 0. Refer to the flow measuring station's chart to determine your unit's airflow velocity.

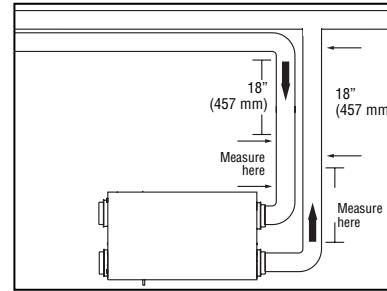

- To avoid airflow turbulence and incorrect readings, the airflow velocity should be measured on steel ducting a minimum of 18" (457 mm) from the unit or elbow and before any transition.

MAINTENANCE

CAUTION MAKE SURE UNIT IS UNPLUGGED BEFORE ATTEMPTING ANY MAINTENANCE WORK

The following components should also be inspected regularly and well maintained.

PRACTICAL TIPS

- To prevent electrical shock, check that the unit is unplugged before doing any repairs or maintenance.
- A yearly inspection is recommended to ensure the efficiency and trouble-free use of your system. Run through the system and verify the different operating modes.

FILTERS

The filters (4) need to be checked and cleaned every three months or when they appear dirty. Wash in warm sudsy water (mild detergent) or use a soft brush vacuum. The filters should be replaced when they can no longer be cleaned properly.

All filters (4) need to be checked regularly

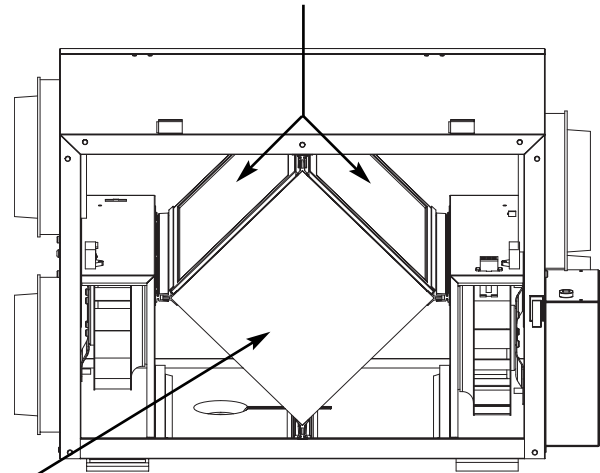

ENERGY RECOVERY CORE

Clean the Enthalpic core annually or as needed with a vacuum cleaner. Use a soft brush attachment. Make sure the filters on the unit are cleaned. Failure to clean or use filters may damage the Enthalpic core resulting in a void WARRANTY.

Note: The use of the Enthalpic core in adverse environment conditions such as dust, oil mist, excessive kitchen grease, corrosive fumes, organic solvents, paint or any other harmful chemicals can damage the Enthalpic core and in such void the warranty.

The motor - The motors are factory balanced and lubricated for life. They require no maintenance.

The unit - The inside of the unit should be vacuumed yearly. Be careful not to damage any of the mechanical components and electrical connections.

The drain pan and drain line - Units with drain lines should have their line and connection checked regularly.

Outside hoods - The outside hoods need to be checked every season to make sure there are no leaves or insects blocking the airflow. Check regularly that there are no pollutants near the intake hood. Make sure they are clear of any snow accumulation during the winter months.

TROUBLESHOOTING

Problem	Causes	Solutions
Air is too dry	Dehumidistat control is set too low ERV out of balance	Increase the desired level of humidity. Change ventilation mode from continuous mode to standby. Balance ERV
Air is too humid	Dehumidistat control is set too high Sudden change in temperature Storing too much wood for heating Dryer vent exhaust is inside home Poor air circulating near windows ERV out of balance Well sealed basement door is closed	Reduce the desired level of humidity. Combine this step with use of continuous exchange mode. Wait until outside temperature stabilizes (winter). Heating will also improve situation. Store a majority of your wood outside. Even dried, a cord of wood contains more than 20 gallons of water. Arrange outside vent for dryer. Open curtains or blinds. Bay or bow windows may require mechanical method. Balance ERV Open the door or install a grill on the door.
Persistent condensation on window	Improper adjustment of dehumidistat control ERV out of balance	Reduce the desired level of humidity. Combine this with the use of continuous exchange mode. Balance ERV
Poor Air Flows	-1/4" (6mm) mesh on the outside hoods is plugged -Filters plugged -Core obstructed -House Grills closed or blocked -Dampers are closed if installed -Poor power supply at site -Ductwork is restricting ERV -Improper speed control setting -ERV airflow improperly balanced	-Clean exterior hoods or vents -Remove and clean filter -Remove and clean core -Check and open Grills -Have electrician check supply voltage at house -Check duct installation -Increase the speed of the ERV -Have contractor balance ERV
Supply air feels cold	-Poor location of supply Grills, the airflow may irritate the occupant -Outdoor temperature extremely cold	-Locate the Grills high on the walls or under the baseboards, install ceiling mounted diffuser or Grills so as not to directly spill the supply air on the occupant (eg. Over a sofa) -Turn down the ERV supply speed. A small duct heater (1kw) could be used to temper the supply air -Placement of furniture or closed doors is restricting the movement of air in the home -If supply air is ducted into furnace return, the furnace fan may need to run continuously to distribute ventilation air comfortably
ERV and / or Ducts Frosting up	-ERV air flows are improperly balanced -Malfunction of the ERV defrost system	-Note: minimal frost build-up is expected on cores before unit initiates defrost cycle functions -Have HVAC contractor balance the ERV
Condensation or Ice Build Up in Insulated Duct to the Outside	-Incomplete vapor barrier around insulated duct -A hole or tear in outer duct covering	-Tape and seal all joints -Tape any holes or tears made in the outer duct covering -Ensure that the vapor barrier is completely sealed.

ELECTRICAL CONNECTIONS

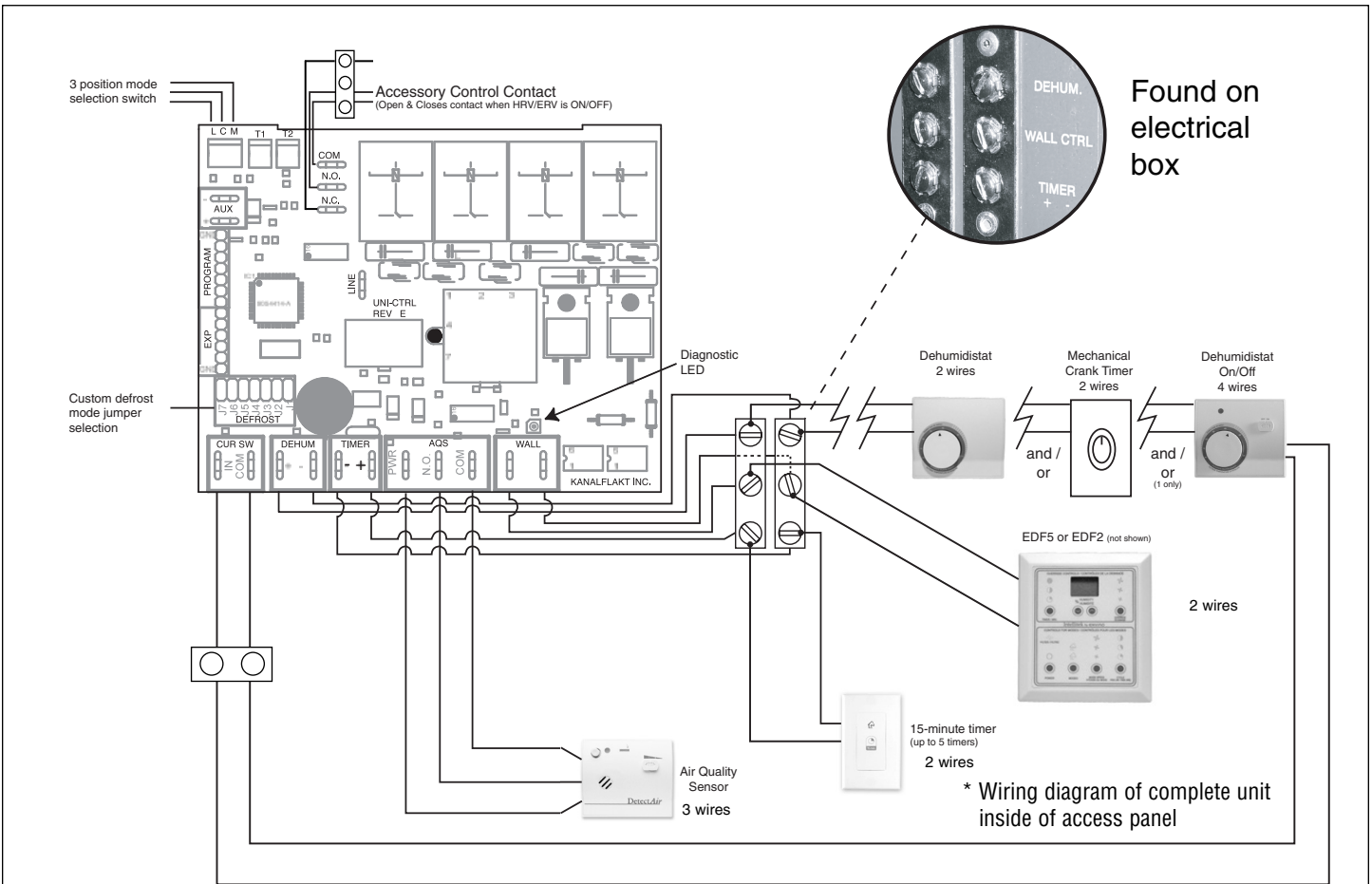

ELECTRICAL CONNECTION TO A FURNACE

PRACTICAL TIPS

Caution:

- Never connect a 120 volt AC circuit to the terminals of the Accessory Control Contacts. Only use the low voltage class 2 circuit of the furnace blower control.

For a Furnace Connected to a Cooling System:

- On some older thermostats, energizing the R and G terminals at the furnace has the effect of energizing Y at the thermostat and thereby turning on the cooling system. If you identify this type of thermostat, you must use the "Alternate Furnace Interlock Wiring".

Standard Accessory Control Contact

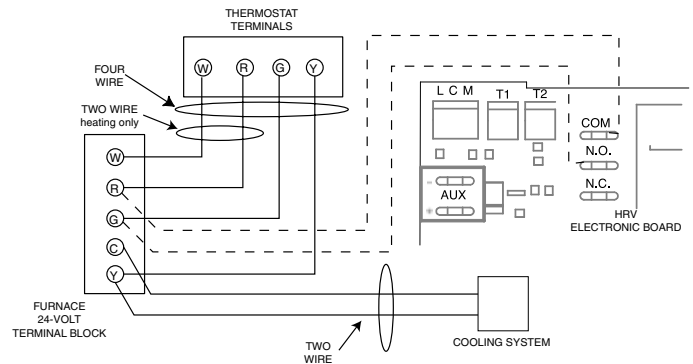

Alternate Accessory Control Contact

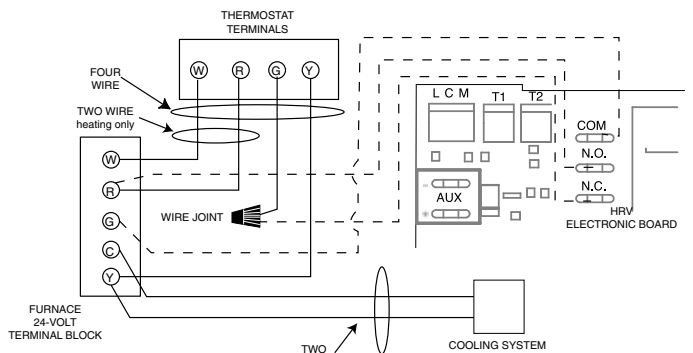

ELECTRICAL WIRING DIAGRAMS

SER 1504, SER 1504N, SER 2004 & SER 2004N

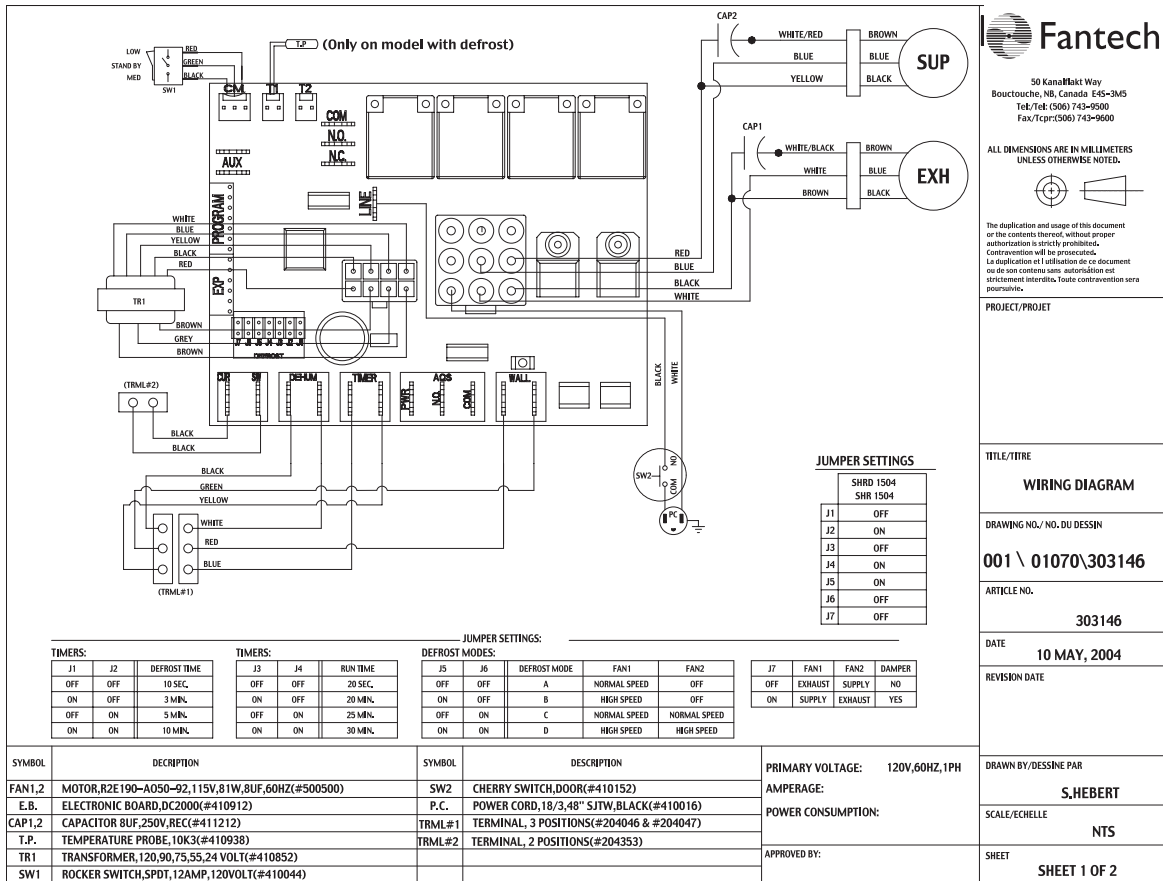

50 KanaBlatt Way
Boucouteche, NB, Canada E45-3M5
Tel./Tél: (506) 743-9500
Fax/Télex: (506) 743-9600

ALL DIMENSIONS ARE IN MILLIMETERS UNLESS OTHERWISE NOTED.

The duplication and usage of this document or the contents thereof, without proper authorization is strictly prohibited. Contrefaçon will be prosecuted. La duplication et l'utilisation de ce document ou de son contenu sans autorisation est strictement interdite. Toute contrefaçon sera poursuivie.

PROJECT/PROJET

TITLE/TITRE
WIRING DIAGRAM

DRAWING NO./ NO. DU DESSIN
001 \ 01070 \ 303146

ARTICLE NO.
303146

DATE
10 MAY, 2004

REVISION DATE

SYMBOL	DESCRIPTION	SYMBOL	DESCRIPTION
FAN1,2	MOTOR,R2E190-A050-92,115V,81W,8UF,60HZ(#500500)	SW2	CHERRY SWITCH,DOOR(#410152)
E.B.	ELECTRONIC BOARD,DC2000(#410912)	P.C.	POWER CORD,18/3,48" SJTW,BLACK(#410016)
CAP1,2	CAPACITOR 8UF,250V,REC(#411212)	TRML#1	TERMINAL, 3 POSITIONS(#204046 & #204047)
T.P.	TEMPERATURE PROBE,10K3(#410938)	TRML#2	TERMINAL, 2 POSITIONS(#204353)
TR1	TRANSFORMER,120,90,75,55,24 VOLT(#410852)		
SW1	ROCKER SWITCH,SPDT,12AMP,120VOLT(#410044)		

PRIMARY VOLTAGE:	120V,60HZ,1PH
AMPERAGE:	
POWER CONSUMPTION:	
APPROVED BY:	

DRAWN BY/DESSIN PAR	S.HEBERT
SCALE/ECHELLE	NTS
SHEET	SHEET 1 OF 2

ELECTRICAL WIRING DIAGRAMS

SER 3204D

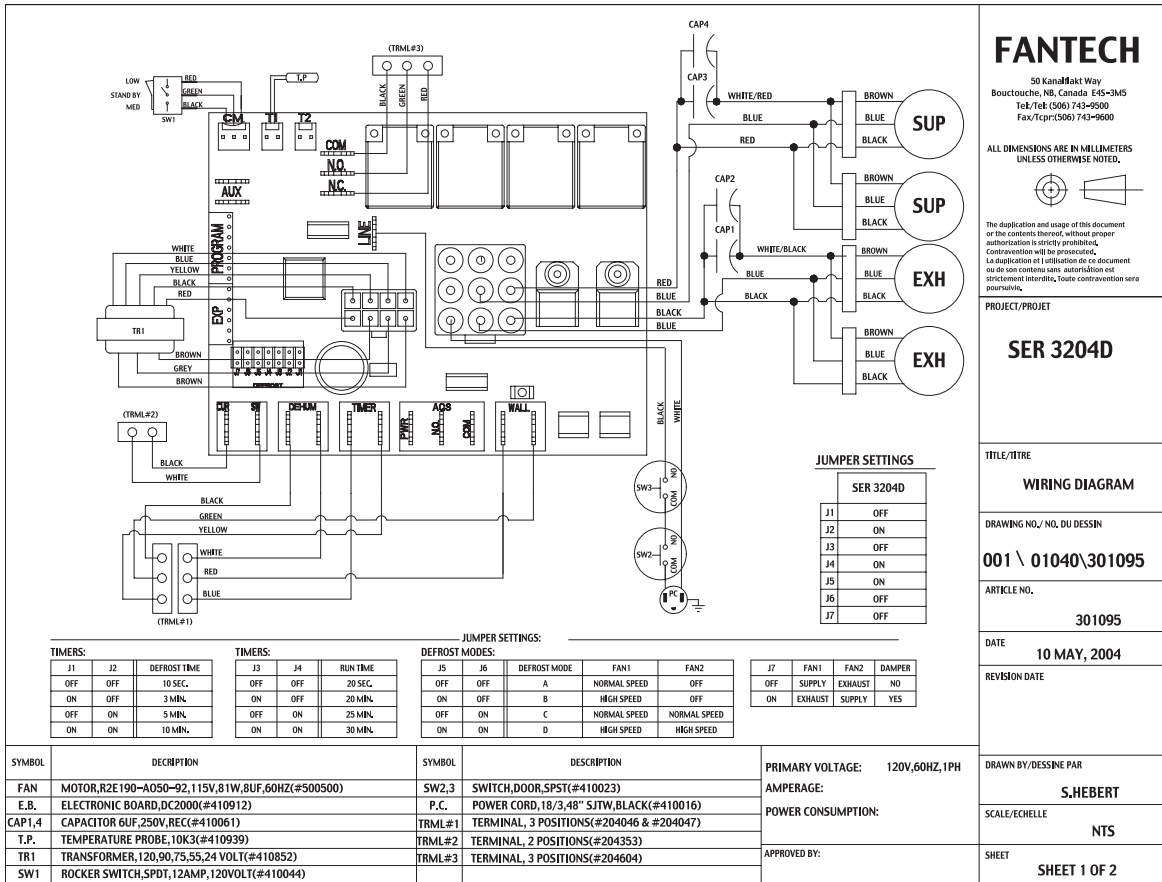

FANTECH

50 KanalBakt Way
 Bouctouche, NB, Canada E4S-3M5
 Tel./Tel (506) 743-9500
 Fax/Fax (506) 743-9600

ALL DIMENSIONS ARE IN MILLIMETERS UNLESS OTHERWISE NOTED.



The duplication and usage of this document or the contents thereof, without proper authorization is strictly prohibited. Contrefaçon will be prosecuted. La duplication et l'utilisation de ce document ou de son contenu sans autorisation est strictement interdite. Toute contrefaçon sera poursuivie.

PROJECT/PROJET

SER 3204D

TITLE/TITRE
WIRING DIAGRAM

DRAWING NO./ NO. DU DESSIN

001 \ 01040\301095

ARTICLE NO.

301095

DATE

10 MAY, 2004

REVISION DATE

DRAWN BY/DESSINE PAR

S.HEBERT

SCALE/ECHELLE

NTS

SHEET

SHEET 1 OF 2

SER 3204N

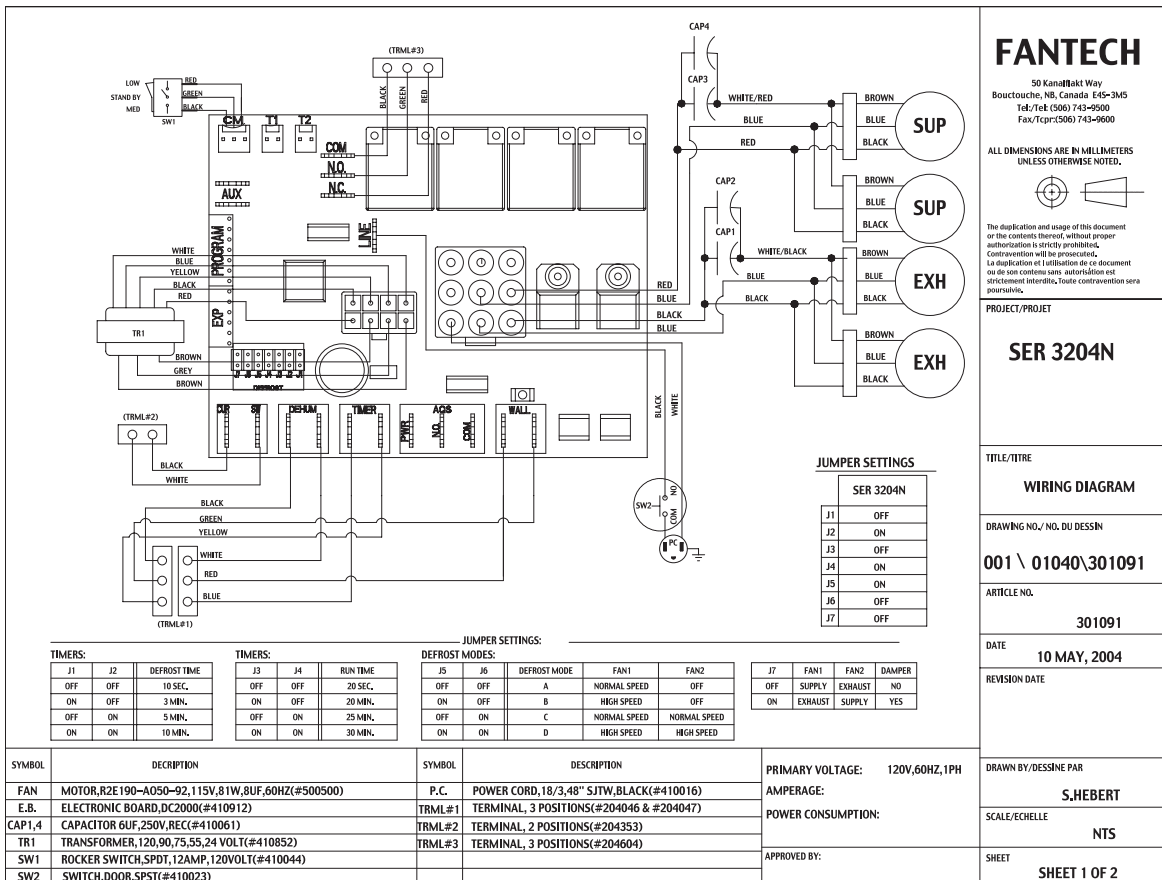

FANTECH

50 KanalBakt Way
 Bouctouche, NB, Canada E4S-3M5
 Tel./Tel (506) 743-9500
 Fax/Fax (506) 743-9600

ALL DIMENSIONS ARE IN MILLIMETERS UNLESS OTHERWISE NOTED.



The duplication and usage of this document or the contents thereof, without proper authorization is strictly prohibited. Contrefaçon will be prosecuted. La duplication et l'utilisation de ce document ou de son contenu sans autorisation est strictement interdite. Toute contrefaçon sera poursuivie.

PROJECT/PROJET

SER 3204N

TITLE/TITRE
WIRING DIAGRAM

DRAWING NO./ NO. DU DESSIN

001 \ 01040\301091

ARTICLE NO.

301091

DATE

10 MAY, 2004

REVISION DATE

DRAWN BY/DESSINE PAR

S.HEBERT

SCALE/ECHELLE

NTS

SHEET

SHEET 1 OF 2



Fantech

United States

1712 Northgate Blvd.,
Sarasota, FL. 34234
Phone: 800.747.1762; 941.309.6000
Fax: 800.487.9915; 941.309.6099
www.fantech.net; info@fantech.net

Canada

50 Kanalfakt Way,
Bouctouche, NB E4S 3M5
Phone: 800.565.3548; 506.743.9500
Fax: 877.747.8116; 506.743.9600
www.fantech.ca; info@fantech.ca

Fantech, reserves the right to modify, at any time and without notice, any or all of its products' features, designs, components and specifications to maintain their technological leadership position.

Article #: 301096
Item #: 401455
Rev Date: 020905