

# MR Modulo

Adjustable Constant  
Airflow Regulator

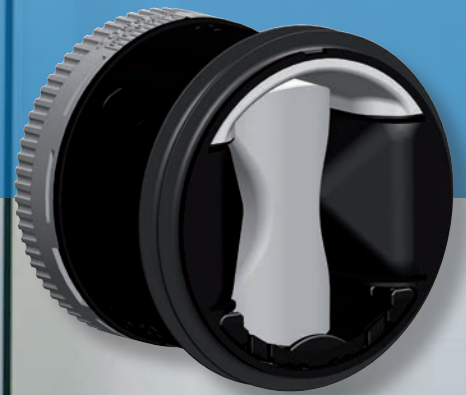





## MR Modulo – balanced airflow with a twist

Airflow balancing is the key to a properly commissioned HVAC system. A balanced system does not suffer from over-ventilation (noise, high temperatures, high energy consumption) or under-ventilation (poor air quality and uncomfortable temperatures). In tightly built structures, ventilation and air-conditioning systems are specifically sized to guarantee that the proper amounts of air exit and enter the building.

Actual operating airflows are often far from the original HVAC system design. Accurate balancing is nearly impossible with traditional balancing dampers. A system may start out balanced, but it is susceptible to pressure fluctuations. Maintaining system balance requires constant adjustments, which are costly and time consuming. Fluctuations are unavoidable, but Aldes has a dynamic solution that preserves system balance.

The Aldes MR Modulo Adjustable Constant Airflow Regulator is a passive device that automatically compensates for changes in static pressure and adjusts to maintain the specified airflow value.

The MR Modulo is an elegant, cost-effective solution. It is available in 5 diameters, and each device supports at least 7 airflow rates. Twist the rotating ring to change the airflow set-point. Then simply insert the MR Modulo into duct or fittings. No tools, no balancing, no maintenance. Buildings large and small can benefit from the MR Modulo.

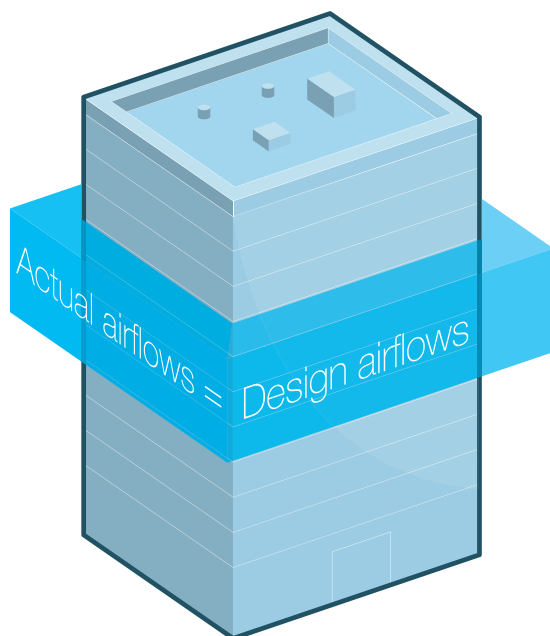

**Unbalanced HVAC system. Actual airflow is only at the specified rate in certain parts of the building.**

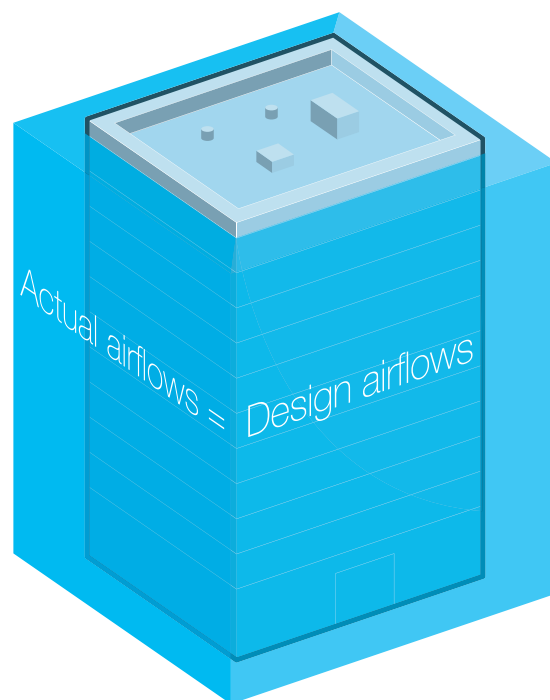

**Balanced HVAC system. Actual airflow is at the specified rate throughout the entire building.**



# Features of the MR Modulo

## Guaranteed quality

100%  
test

- Every unit is run-tested.
- 5-year warranty.



## Easy to install



- No manual balancing.
- Tool-free airflow setting.
- Self-powered, no wiring or electricity required
  - Can be inserted into duct and fittings.
  - Multi-position mounting.

MR Modulo Adjustable Constant Airflow Regulators balance airflows in ventilation or air conditioning ductworks. They fit easily into round ductwork to maintain constant and reliable airflow within a wide range of differential pressure (0.2-1.0 in. w.g./50 - 250 Pa).

The MR Modulo's flexible membrane inflates and deflates according to the difference in pressure between the upstream and downstream flow, thus modifying the airflow. **This principle of operation guarantees constant airflow regardless of pressure variations in the ductwork.**



## Precise Airflow Regulation



- Regulating silicone membrane resists clogging and requires no maintenance.
- Silent operation: no mechanical clatter or other noise interference due to variations in pressure.
- Available in 5 diameters, each one with multiple airflow set-points.

## Smart design



- Double-lip seal for secure, air-tight fit.
- Rotating ring for on-site airflow setting (patent pending).
- Made of recyclable, chlorine-free plastic that meets UL 2043 standards for flame and smoke generation.
- Stainless steel regulation spring.

# Technical Details

## Airflow Range

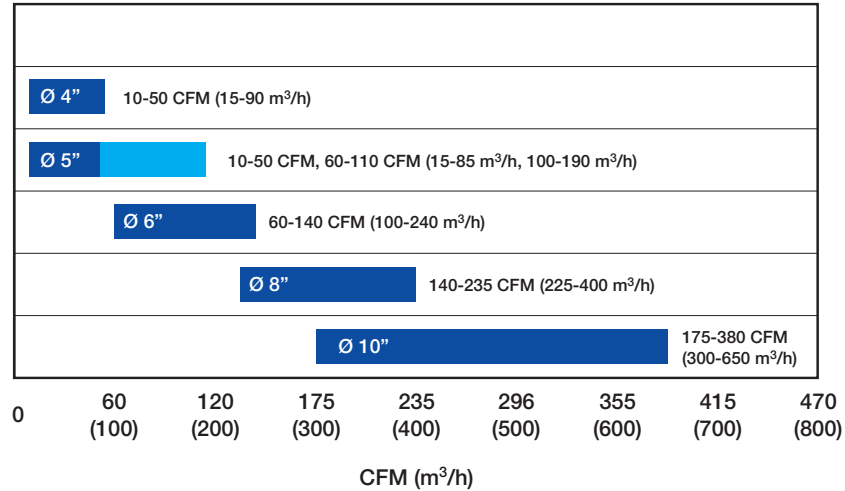

### Airflow Accuracy:

- +/- 3 CFM (5 m<sup>3</sup>/h) for nominal flow ≤ 30 CFM (50 m<sup>3</sup>/h)
- +/- 10% for nominal flow > 30 CFM (50 m<sup>3</sup>/h)

**Operating Pressure Range:** 0.2-1.0 in. w.g. (50-250 Pa)

**Operating Temperature Range:** 14 to 140°F (-10 to 60°C)

## Dimensions & Weight

Ø Duct	ØN	ØB	A	Weight
4" (100 mm)	3.62 (92 mm)	4.13 (105 mm)	2.76 (70 mm)	0.26 lbs (0.12 kg)
5" * (125 mm)	4.57 (116 mm)	5.20 (132 mm)	2.76 (70 mm)	0.33 lbs (0.15 kg)
5" ** (125 mm)	4.57 (116 mm)	5.20 (132 mm)	4.33 (110 mm)	0.37 lbs (0.17 kg)
6" (150 mm)	5.79 (147 mm)	6.02 (153 mm)	4.65 (118 mm)	0.82 lbs (0.37 kg)
8" (200 mm)	7.48 (190 mm)	8.27 (210 mm)	5.67 (144 mm)	1.31 lbs (0.59 kg)
10" (250 mm)	9.37 (238 mm)	10.32 (262 mm)	7.05 (179 mm)	2.25 lbs (1.02 kg)

\* 10-50 CFM (15-85 m<sup>3</sup>/h)

\*\* 60-110 CFM (100-190 m<sup>3</sup>/h)

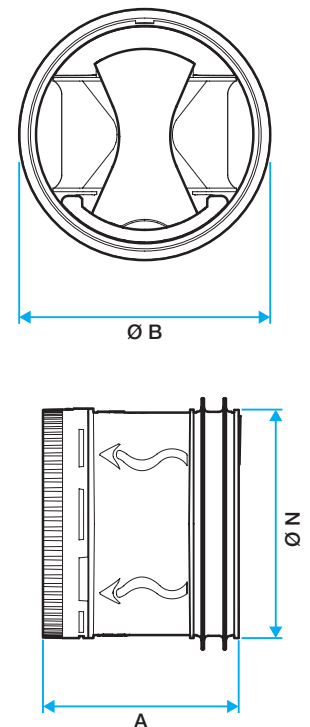

## Installation

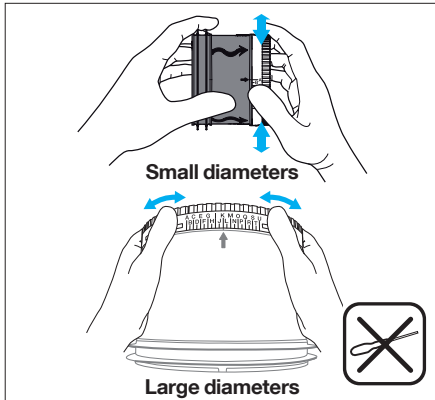

### 1. Adjust the airflow setting.

Twist the rotating adjustment ring until the desired airflow is reached (correlation table printed on the device). No tools are required.

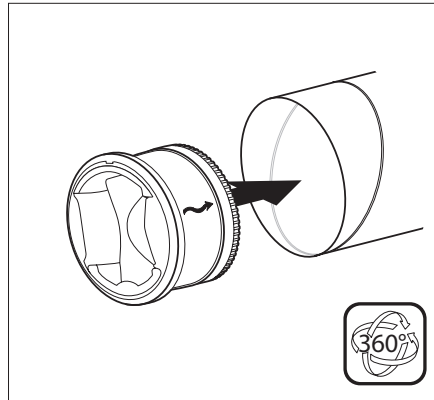

### 2. Position the MR Modulo.

Introduce the MR in the duct according to the arrow that shows the airflow direction. There is no recommendation regarding the membrane positioning.

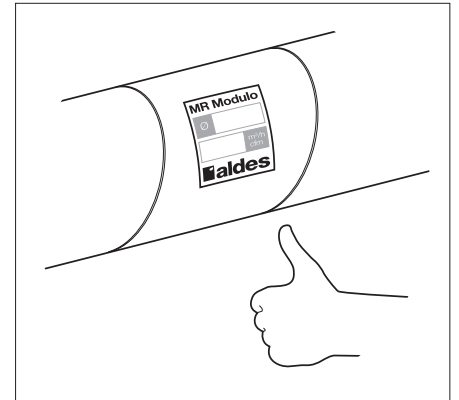

### 3. Product localization.

MR Modulo is delivered with a sticker that will need to be filled out on-site (diameter and airflow setting) and placed directly onto the duct to indicate where MR Modulo has been mounted.

## Product Information

The following information is indicated on the product:

- Airflow direction
- Diameter in mm and inches
- Airflow settings correlation table
- Differential pressure operating range
- Product code
- Date of manufacture

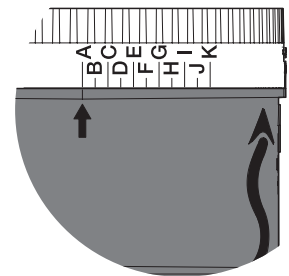
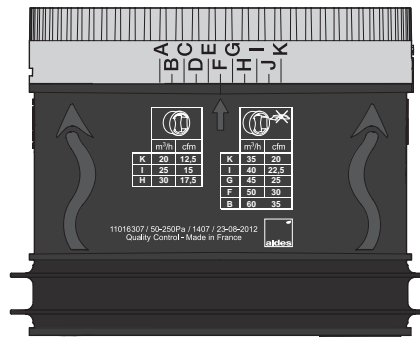

## Warranty & Maintenance

- MR Modulo performance is not altered by clogging, therefore it requires practically no special maintenance.
- If the intended application includes air heavily loaded with grease or dust, a fitting with an access panel or door, such as that used for flame dampers, should be used.
- Five (5) year warranty

[www.aldes.us](http://www.aldes.us)

Distributed By:

American ALDES Ventilation Corporation  
4521 19th Street Court East, Suite 104 - Bradenton, FL 34203 USA  
Tel: 941.351.3441 - Fax: 941.351.3442 - Toll-Free: 1.800.255.7749

© 2014 American ALDES Ventilation Corporation. Reproduction or distribution, in whole or in part, of this document, in any form or by any means, without the express written consent of American ALDES Ventilation Corporation, is strictly prohibited. The information contained within this document is subject to change without prior written notice.

