



F300E Electronic Air Cleaner

PRODUCT DATA



FEATURES

- Available in four sizes to fit most ducts; adapts to airflow from either side.
- Capacity varies from 1200 cfm (2040 m³/hr) to 2000 cfm (3400 m³/hr), depending on size.
- Solid state power supply is self-regulating and maintains peak efficiency during a wide range of cell dirt loading conditions.
- Pressure drop is approximately equal to that of a regular fiberglass filter.
- Optional W8600F Air Cleaner Monitor indicates air cleaner performance, reminds homeowner when a cell and prefilter wash is due, and when to check the system.
- Optional wireless W8600A AIRWATCH™ LCD indicator provides reminder when air cleaner electronic cells need washing, as well as reminder when UV lamps need replacing and when humidifier pad needs replacing.
- Galvanized cabinet protects against rust.
- Neon light next to on-off switch tells if air cleaner is powered and if high voltage is present.
- Prefilter screens protect cells from large dirt particles.

APPLICATION

The F300E Electronic Air Cleaner is mounted in the return air duct of a forced air heating, cooling, or ventilating system. It captures a significant amount of the airborne particles 0.3 microns and larger from the air circulated through it.

Contents

Application	1
Features	1
Specifications	2
Ordering Information	2
Planning the Installation	4
Installation	7
Operation	13
Checkout	13
Service	13
Replacement Parts/Exploded View	18
Electrical Troubleshooting	20



SPECIFICATIONS

IMPORTANT

The specifications given in this publication do not include normal manufacturing tolerances. Therefore, this unit may not exactly match the listed specifications. This product is tested and calibrated under closely controlled conditions, and some minor differences in performance can be expected if those conditions are changed.

Model:

Electronic Air Cleaner: Includes cabinet, access door, solid state power supply, two electronic cells and two prefilters.

Electrical Ratings:

Voltage and Frequency: 120V, 60 Hz. Can be converted in the field to 240V, 60 Hz or 220/240V, 50 Hz with the 203365A Conversion Kit.
 Power Consumption: 36W maximum.
 Current Draw: See Table 1.
 Ionizer Voltage: 8150 Vdc.
 Collector Voltage: 4075 Vdc.

Capacity, Efficiency, Pressure Drop:

See Fig. 1, for capacity, pressure drop and ASHRAE dust spot efficiencies.

Fractional Efficiency:

70% efficient on 0.3 micron particles at 500 fpm.
 90% efficient on 1.0 micron particles at 500 fpm.
 99% efficient on 10.0 micron particles at 500 fpm.

Temperature Ratings:

Operating Ambient: 40° to 125°F (4° to 52°C).
 Temperature of Airflow Through Cells: 40° to 125°F (4° to 52°C).
 Maximum Cell Washing Temperature: 220°F (140°C).
 Storage and Shipping Ambient: Minus 40°F to plus 140°F (minus 40°C to plus 60°C).

Mounting:

Mounts in the return air duct of a forced air heating, cooling, or ventilating system. Mount upstream from the atomizing humidifier. See the Planning the Installation section.

Table 1. Current Draw.

Size		No. Cells	Max. Current (A)	
			120V	220/240V
in.	mm			
16 x 20	406 x 508	2	0.4	0.2
16 x 25	406 x 635	2	0.4	0.2
20 x 20	508 x 508	2	0.4	0.2
20 x 25	508 x 635	2	0.4	0.2

Table 2. Shipping and Installation Weight.

	Weight							
	16 x 20 in. (406 x 508 mm)		16 x 25 in. (406 x 635 mm)		20 x 20 in. (508 x 508 mm)		20 x 25 in. (508 x 635 mm)	
	lb	kg	lb	kg	lb	kg	lb	kg
Electronic Cell (Each)	5	2.25	6	2.7	6-3/16	2.8	7-1/2	3.4
Shipping Weight	30	13.6	33	15.0	33	15.0	38	17.2
Installed Weight (Cells Included)	26	11.6	28	12.7	29	13.2	33	15.0

ORDERING INFORMATION

When purchasing replacement and modernization products from your TRADELINE® wholesaler or distributor, refer to the TRADELINE® Catalog or price sheets for complete ordering number, or specify

1. Order number.
2. Voltage and frequency.
3. Dimensions: 16 x 20, 16 x 25, 20 x 20, or 20 x 25 in. (406 x 508, 406 x 635, 508 x 508, or 508 x 635 mm).
4. Conversion kit for changing two cell 120V, 60 Hz models to 240V, 60 Hz or 220/240V, 50 Hz.
5. W8600F Air Cleaner Monitor, if desired.
6. W8600A AIRWATCH™ Indicator, if desired.

If you have additional questions, need further information, or would like to comment on our products or services, please write or phone:

1. Home and Building Control Customer Assistance
 Honeywell, 1885 Douglas Drive North
 Golden Valley, MN 55422-4386 (612) 951-1000
2. Visit our web site @ www.honeywell.com/yourhome/

In Canada—Honeywell Limited/Honeywell Limitée, 155 Gordon Baker Road, North York, Ontario M2H 3N7.
 International Sales and Service Offices in all principal cities of the world. Manufacturing in Australia, Canada, Finland, France, Germany, Japan, Mexico, Netherlands, Spain, Taiwan, United Kingdom, U.S.A.

AIR CLEANER EFFICIENCY AND PRESSURE DROP AT VARIOUS AIRFLOW RATES.

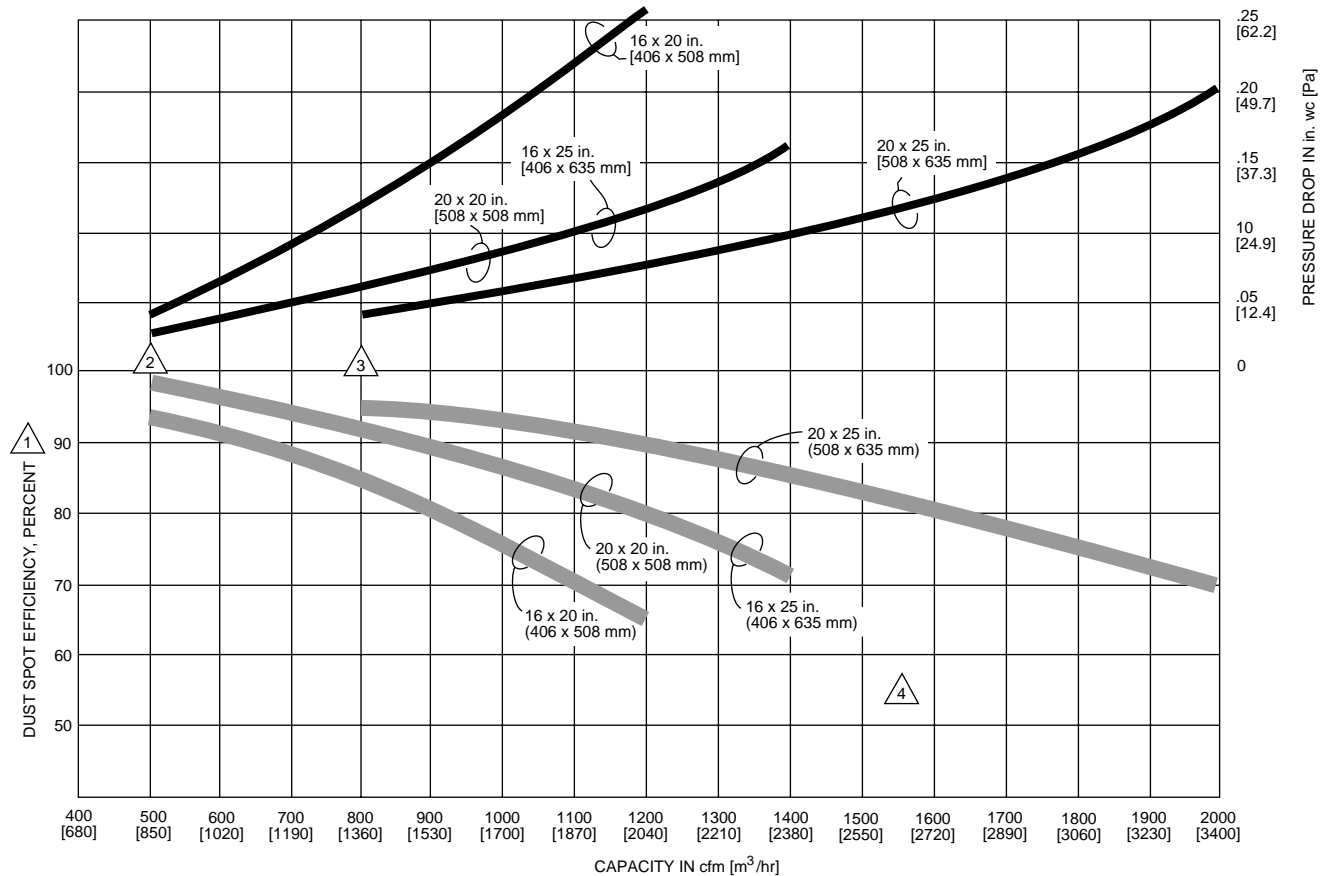

△1 EFFICIENCY RATINGS BASED ON NATIONAL BUREAU OF STANDARDS INITIAL DUST SPOT METHOD USING ATMOSPHERIC DUST, AND AMERICAN SOCIETY OF HEATING, REFRIGERATING AND AIR-CONDITIONING ENGINEERS STANDARDS 52.1-92.

△2 MINIMUM RECOMMENDED cfm FOR 16 x 25 in. [406 x 635 mm], 20 x 20 in. [508 x 508 mm], 16 x 20 in. [406 x 508 mm] MODELS.

△3 MINIMUM RECOMMENDED cfm FOR 20 x 25 in. [508 x 635 mm] MODEL.

△4 SELECT SIZE THAT MOST CLOSELY FITS DIMENSIONS OF FURNACE/AIR HANDLER RETURN AIR OPENING

M14730

Fig. 1. Air cleaner efficiency and pressure drop at various airflow rates.

Weight:

See Table 2.

Dimensions:

See Fig. 2.

Underwriters Laboratories Inc. Listed:

File No. E30954.

Accessories:

203365A Conversion Kit for changing 120V, 60 Hz power supply to 240V, 60 Hz or 220/240, 50 Hz.

W8600F Air Cleaner Monitor.

W8600A AIRWATCH™ Indicator.

Repair Parts:

See Replacement Parts/Exploded View section.

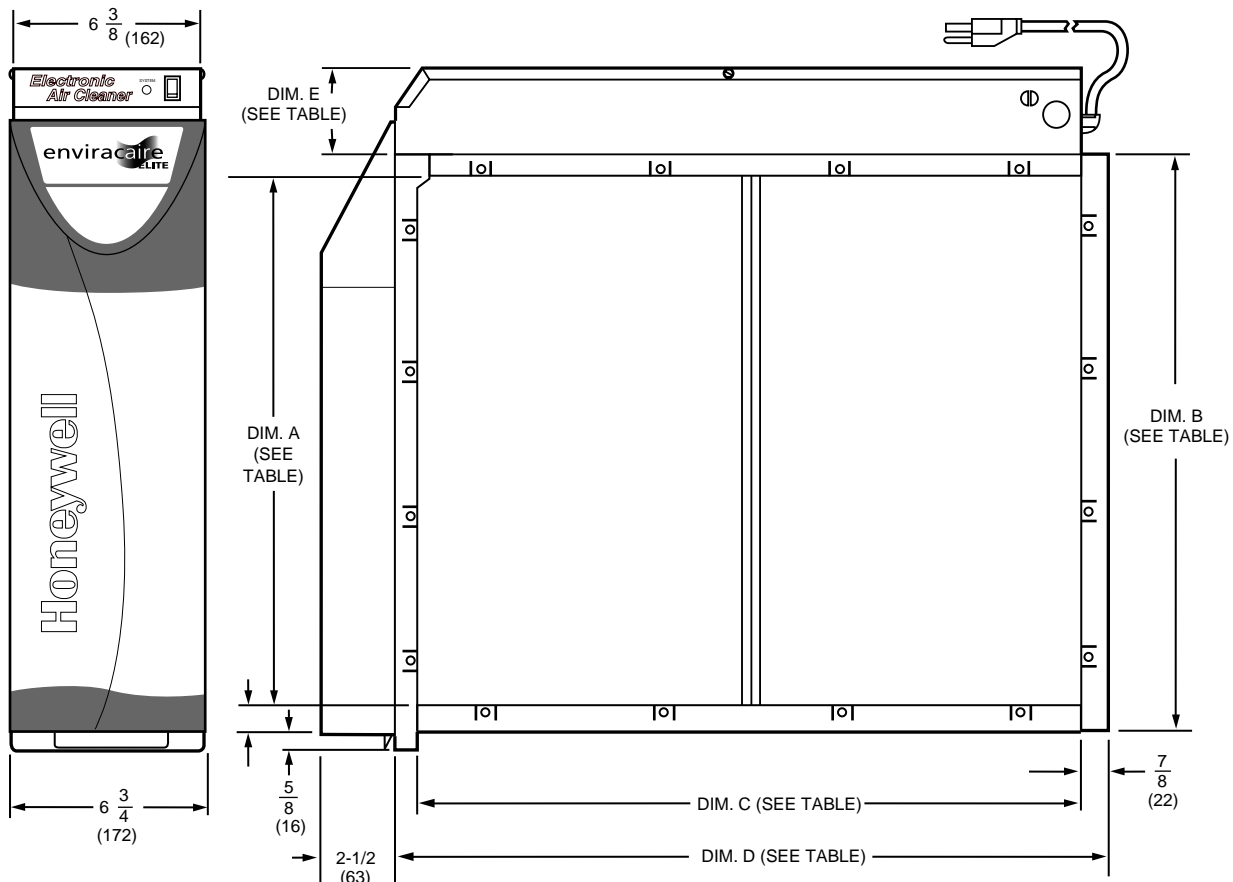

F300		DIM. A		DIM. B		DIM. C		DIM. D		DIM. E	
IN.	MM	IN.	MM	IN.	MM	IN.	MM	IN.	MM	IN.	MM
16 X 25	406 X 635	14 7/16	367	16 3/16	411	23 1/4	591	25	626	2 3/4	70
16 X 20	406 X 508	14 7/16	367	16 3/16	411	18 1/4	457	20	509	2 3/4	70
20 X 25	508 X 635	18 7/16	468	20 3/16	513	23 1/4	591	25	626	2 3/4	70
20 X 20	508 X 508	18 7/16	468	20 3/16	513	18 1/4	457	20	509	2 3/4	70

M14731

Fig. 2. Installation dimensions of Electronic Air Cleaner in in. (mm).

PLANNING THE INSTALLATION

Application

The F300E Electronic Air Cleaner is used in a forced air heating, cooling, or ventilating system. It removes airborne particles from the air circulated through it. All models have an internal air flow switch that operates the air cleaner when the system blower is on.

Review Installation Requirements

The air cleaner should be installed where all the air passing through the system circulates through it. The best location is in the return air duct next to the blower compartment so the air cleaner can help keep the blower motor and evaporator coils clean.

IMPORTANT

Do not mount in the discharge air duct.

For most efficient air cleaning, airflow must be spread evenly across the face of the air cleaner. If the duct is a different size than the air cleaner cabinet, gradual transitions are recommended. If the duct turns sharply just before the air cleaner, turning vanes are recommended.

Applications with Air Conditioning

The air cleaner should be installed upstream from the evaporator coil. The air cleaner will help keep the coil clean, reducing maintenance.

Applications with a Humidifier

An evaporative humidifier can be mounted upstream from the air cleaner. An atomizing humidifier should be mounted downstream from the air cleaner, even though hard water salts will be blown into the living space and deposited as dust. If an atomizing humidifier must be mounted upstream from the air cleaner:

1. Mount it as far as possible upstream from the air cleaner.
2. Install a standard disposable furnace filter between the humidifier and the air cleaner to trap water droplets and hard water salts.
3. Frequently clean the air cleaner to prevent a hard water salt buildup.

NOTE: The volume of water that passes through an atomizing humidifier can overload the air cleaner, resulting in hard water salts being deposited as dust in the living space.

Applications with an Activated Carbon Filter

An activated carbon (charcoal) filter can be used to remove odors or other gaseous contaminants (not particle-based) that are not removed by the air cleaner. Locate the carbon filter:

- Downstream from the air cleaner. This means that dust from the carbon filter will not be collected by the air cleaner and will be deposited in the living space.
- Outside the air cleaner cabinet. Some carbon filters are combustible and contact with high voltage could result in smoke or fire.
- Where carbon granules cannot fall into the electronic cell. If necessary, use a disposable furnace filter between the carbon filter and the electronic cell.
- With proper transitions, if the activated carbon filter requires a differently sized duct than the air cleaner. Allow 20 degrees expansion per side, per fitting.

NOTE: Honeywell does not offer carbon filters. Refer to an activated carbon filter manufacturer for sizing and application.

Applications with Outdoor Air Intake

Return air temperature must be at least 40°F (4°C). Lower temperatures can cause ionizer wire failure. If outdoor air is used, warm it upstream from the air cleaner by:

- Making sure the outdoor intake is far enough upstream from the air cleaner so the return and outdoor air is thoroughly mixed. Stratified air can dump a stream of very cold air into one section of the air cleaner.
- Adding baffles upstream from the air cleaner to force thorough air mixing.
- Installing a Honeywell Home Ventilation System that transfers up to 80 percent of the heat from the exhaust air to the incoming outside air. This keeps the incoming air above 40°F (4°C) and reduces energy usage.
- Installing a preheater if large amounts of outdoor air are used. The preheater, which could be an electric strip heater or hot water coil, should be controlled by a thermostat. Hot water or steam coils should be protected by a freeze-up control.

Optional W8600F Air Cleaner Monitor

The terminal board is recessed slightly so it or the wires will not interfere with installation. The entire power supply box can be unplugged and removed to provide access to the terminals. The W8600F Air Cleaner Monitor can be mounted in the living area or in the furnace room. It should be located in a convenient location to observe the display.

Optional W8600A AIRWATCH™ Indicator

The W8600A can be mounted next to the thermostat or in any other location in the living area of the home where the display can be conveniently observed. No wiring is necessary.

Choose Location

Choose a location that is readily accessible for regular inspection and cleaning. Allow at least 13 in. (330 mm) in front of the access door for removing the prefilter and electronic cell. Allow enough room above the power supply so it can be serviced without removing pipes, ducts, or other heating system components.

The air cleaner must be installed where the temperature will not exceed 40° to 125°F (4° to 52°C).

Choose Mounting Position

WARNING

Heavy Equipment.

Can cause injury or equipment damage.

Do not mount the air cleaner with the access door facing down. If the access door faces down, the latch may not hold, and the cell and prefilter can fall unexpectedly. Also, nothing holds the cell and prefilter in place when the access door is opened.

The air cleaner can be mounted in any position except with the access door facing down. Following is a list of air cleaner mounting positions for a variety of furnace installations.

NOTE: At least 13 in. (330 mm) clearance is required between the access door and any obstructions for cell and prefilter maintenance.

- Upflow “Highboy” furnace: Side installation; air cleaner is mounted vertically where return enters side inlet of furnace. See Fig. 3A.
- Upflow “Highboy” furnace: Installation beneath furnace (air cleaner cabinet can easily support weight of furnace and air conditioner coil). Air cleaner is mounted horizontally where return enters from below. See Fig. 3B.
- Upflow “Highboy” furnace: Closet installation. Air cleaner is mounted vertically on furnace between furnace and louvered return air opening in closet door. See Fig. 3C.
- “Lowboy” furnace: Air cleaner is mounted horizontally in return plenum just above furnace, opposite of supply plenum. See Fig. 3D.
- Downflow “Counterflow” furnace: Air cleaner is mounted horizontally in return duct or plenum just above furnace. See Fig. 3E.
- High capacity system: Two or more air cleaners can be used together. See Fig. 3F.
- Horizontal furnace: Air cleaner is mounted vertically where return enters. See Fig. G.

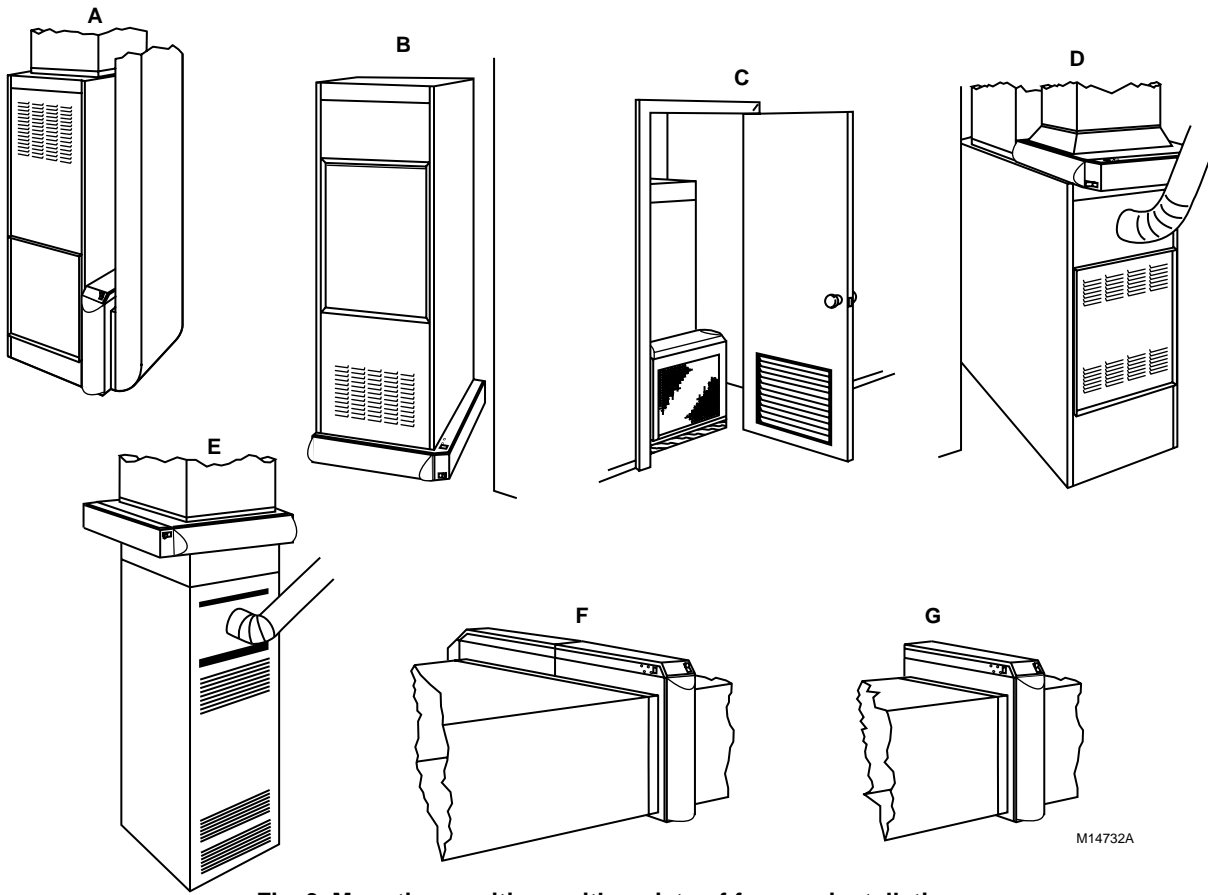

Fig. 3. Mounting positions with variety of furnace installations.

Determine Duct Design Requirements

The air cleaner is adaptable to all new or existing forced air heating, cooling and ventilating systems used in residential applications. Transitions, turning vanes, or offsets may be needed in some applications for effective operation.

Transitions

Transitions are needed when the duct is a different size than the air cleaner cabinet. Gradual transitions reduce air turbulence and increase efficiency. Limit expansion to no more than 20 degrees or about 4 in. per running foot (100 mm per 300 linear mm) on each side of a transition fitting. See Fig. 4.

CHANGE DUCT SIZE GRADUALLY TO MINIMIZE TURBULENCE.

20 DEGREE EXPANSION PER SIDE PER FITTING (4 in. PER LINEAR FOOT [100 mm PER 300 LINEAR mm]).

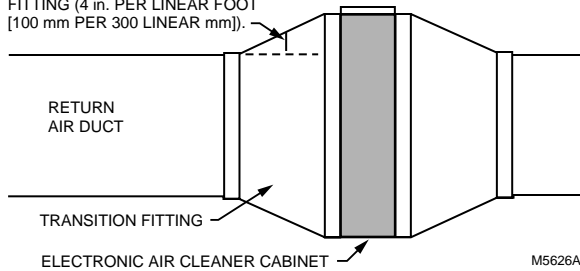

Fig. 4. Change duct size gradually to minimize turbulence.

Turning Vanes

If the air cleaner is installed close to an elbow or angle fitting, install turning vanes inside the angle to distribute airflow more evenly across the face of the cell. See Fig. 5.

Offsets

If the duct connection to the furnace in a side installation allows less than 7 in. (178 mm) for mounting the air cleaner cabinet, add an offset to the elbow. See Fig. 5.

TYPICAL USE OF DUCT OFFSET TO ALLOW SPACE FOR ELECTRONIC AIR CLEANER.

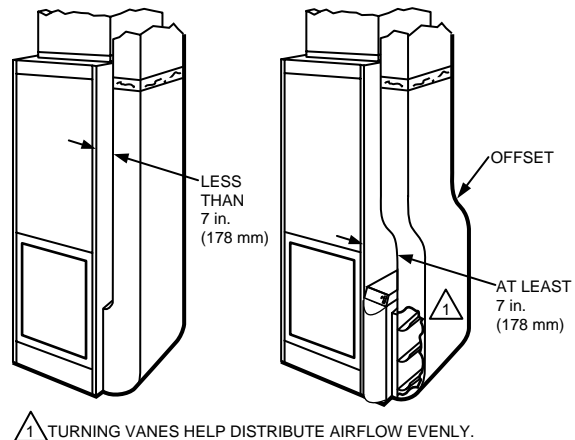

1 TURNING VANES HELP DISTRIBUTE AIRFLOW EVENLY.

M14733

Fig. 5. Typical use of duct offset to allow space for electronic air cleaner.

INSTALLATION

When Installing this Product...

1. Read these instructions carefully. Failure to follow them could damage the product or cause a hazardous condition.
2. Check the ratings given in the instructions and on the product to make sure the product is suitable for your application.
3. Installer must be a trained, experienced service technician.
4. After installation is complete, check out product operation as provided in these instructions.

WARNING

Electric Shock Hazard.
Can cause electrical shock or equipment damage.

Do not connect to power before installation is complete.

Unpack Electronic Air Cleaner

- Check that all components are included. The electronic air cleaner is shipped assembled. The unit consists of a galvanized steel cabinet, power supply with on-off switch and neon light, two electronic cells and prefilters, access door, and product data literature.
- Order W8600F (optional), mounting hardware and installation literature separately.
- Order W8600A (optional), including mounting hardware, batteries, and literature separately.

Clean Blower Compartment

- Remove and discard the existing furnace filter.
- Thoroughly clean the blower compartment.
- If possible, power vacuum the ductwork to remove accumulated dust in an existing home, or construction dirt in a new home. The electronic air cleaner cannot remove dust that has settled in the blower compartment and distribution ducts.
- Check the edges of the furnace fan blades for dirt buildup and clean as necessary. The fan will not deliver the rated cfm if the blades are dirty.

Fasten Cabinet To Furnace

NOTE: This procedure shows a side installation on a typical highboy furnace. You may need to alter the procedure to fit your application.

- Remove and set aside the access door, electronic cell(s) and prefilter(s).
- Align the cabinet with the return air opening.
- Create opening in furnace to match air cleaner cabinet opening.
- Install a transition when the furnace and air cleaner openings are different sizes. See Fig. 4.

- Place blocks under the cabinet so the unit is firmly supported and level. The 5/8 in. (16 mm) mounting foot on the cabinet hinge plate provides the minimum clearance required for the access door hinge.
- Attach the cabinet securely to the furnace. The unit can be attached directly, as shown, or a starting collar can first be fitted in the furnace opening. Either drill holes and fasten with sheet metal screws or rivets, or use slip joints. See Fig. 6.

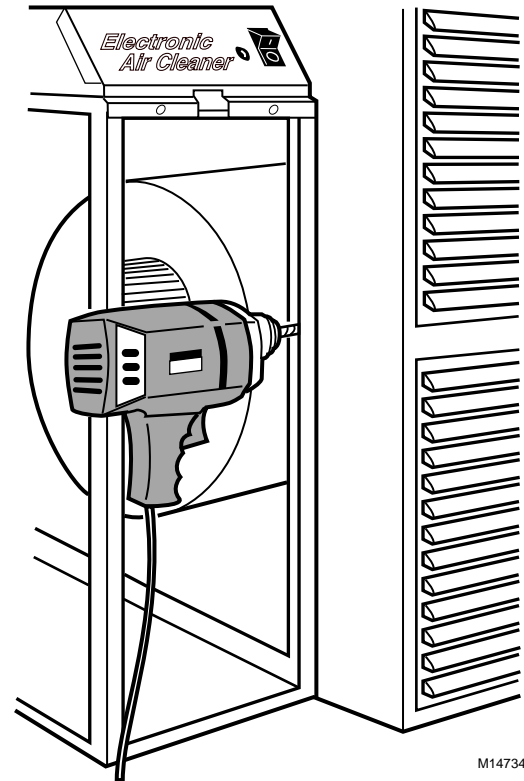

Fig. 6. Fasten cabinet to furnace.

Install Turning Vanes

- Mount turning vanes inside the elbow or angle fitting that is directly against the air cleaner cabinet. See Fig. 5 and 7.

Fasten Cabinet To Ductwork

- Install a transition when the opening in the air cleaner cabinet and the duct are different sizes. See Fig. 4.
- Fasten the other side of the cabinet to the elbow using sheet metal screws, rivets, or slip joints as appropriate. If drilling holes, use locking pliers to help hold the unit in place during drilling. See Fig. 7.

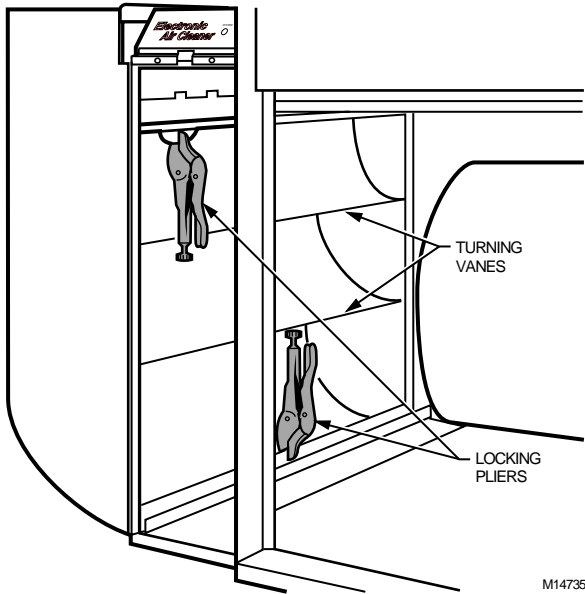

Fig. 7. Connect ductwork to air cleaner. Note turning vanes. Locking pliers hold duct to air cleaner cabinet during installation.

Table 3. Description of W8600F Function Indicator Panel.

Indicators	Condition
ON	EAC is powered and system blower is running.
BATTERY	Battery that maintains W8600F memory is low and needs to be replaced.
SERVICE	EAC prefilter and cells need to be washed .
FAULT	<ul style="list-style-type: none"> Shorting of collector plates. Continuous ionizer or collector plate arcing. Power supply failure. Excessive current. Major reduction in high voltage. EAC prefilter and cells are past SERVICE level of dirt and need to be washed immediately. Call a service technician.

W8600F Location

The styling of the W8600F is designed to blend with the latest T8600 family of Honeywell Chronotherm® IV Deluxe Programmable Thermostats. A special mounting template is included for mounting next to the T8600. The W8600F can also be mounted at any other convenient location in the living area or equipment room.

NOTE: The W8600F shares no electrical connections with the thermostat.

Install Optional W8600F Air Cleaner Monitor

The W8600F Air Cleaner Monitor is an option available for use with the F300E.

The W8600F function indicator panel has four liquid crystal display (LCD) arrowheads that point to ON, BATTERY, SERVICE or FAULT. See Fig. 8. The arrowheads darken to indicate the existing EAC condition. See Table 3.

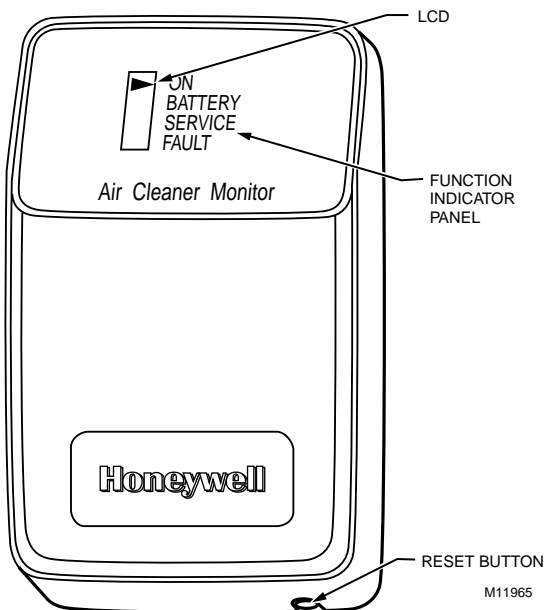

Fig. 8. W8600F Air Cleaner Monitor features.

Mounting

The following mounting instructions assume that the W8600F is mounted next to a T8600 Thermostat. If installing the monitor at another location, modify the procedure to fit the installation.

1. Hold the mounting template (included in the bag assembly) next to the T8600 as shown in Fig. 9.
2. Mark the holes for the screw anchors and the 3-conductor thermostat cable.
3. Remove the template and drill the holes.
4. Remove the W8600F from the base.
5. Position the W8600F base over the holes and install the anchors and screws. Tighten the screws until the base is mounted firmly on the wall.

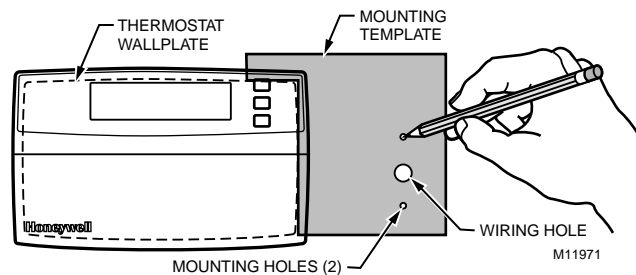

Fig. 9. Positioning mounting template.

Select Wash Frequency

Use the W8600F DIP switches to program the time between SERVICE indications. Be sure to select the setting according to the conditions of the home. Factors to consider include the duty cycle of the EAC, the number of people and pets, and activities such as woodworking and other crafts that are being done in the home.

Refer to Table 4 to select the wash frequency. Set the W8600F DIP switches to match the selection. See Fig. 10. The time listed represents actual run time of the EAC, not calendar days.

Table 4. Wash Frequency Options.

DIP Switch Settings			Wash Frequency (Days)
F1	F2	F3	
Off	Off	Off	10
Off	Off	On	20
Off	On	Off	30
Off	On	On	40
On	Off	Off	50
On	Off	On	70
On	On	Off	100
On	On	On	180

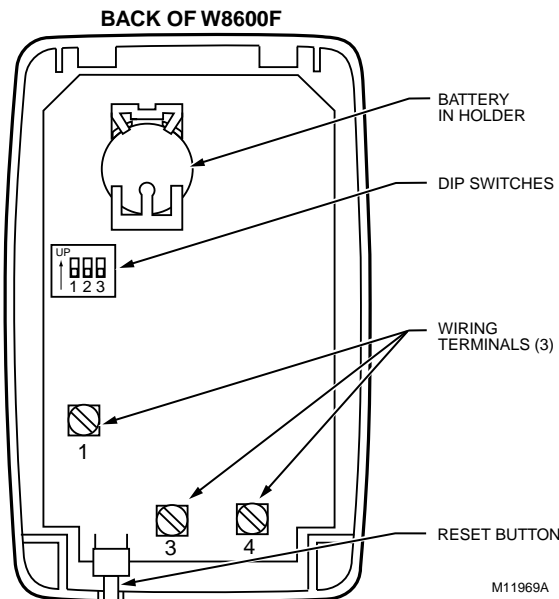

Fig. 10. Back of W8600F.

Wiring

1. Run a 3-conductor thermostat cable (up to 18 gauge) from the W8600F to the terminal strip on the air cleaner.

IMPORTANT

Connect cable to W8600F before attaching to the air cleaner terminals to minimize the risk of damage due to static electricity.

2. Connect the wires to terminals 1, 3 and 4 on the W8600F. See Fig. 10.
3. Check that the battery is correctly installed in the W8600F battery holder.
4. Snap the W8600F onto the base.
5. Turn off the power for the EAC.

⚠ WARNING

Electric Shock Hazard.

Can cause electrical shock or equipment damage.

Disconnect EAC power and open the access door before opening the power supply box cover.

6. Open the power supply box cover.
7. Remove the plug from the side of the power supply box (plug can be a metal knockout or a blank terminal strip).
8. Install the terminal block/cable assembly supplied with W8600F kit.
9. Plug the connector on the end of the cable assembly into the J2 terminal on the driver board (included with W8600F kit). See Fig. 11.

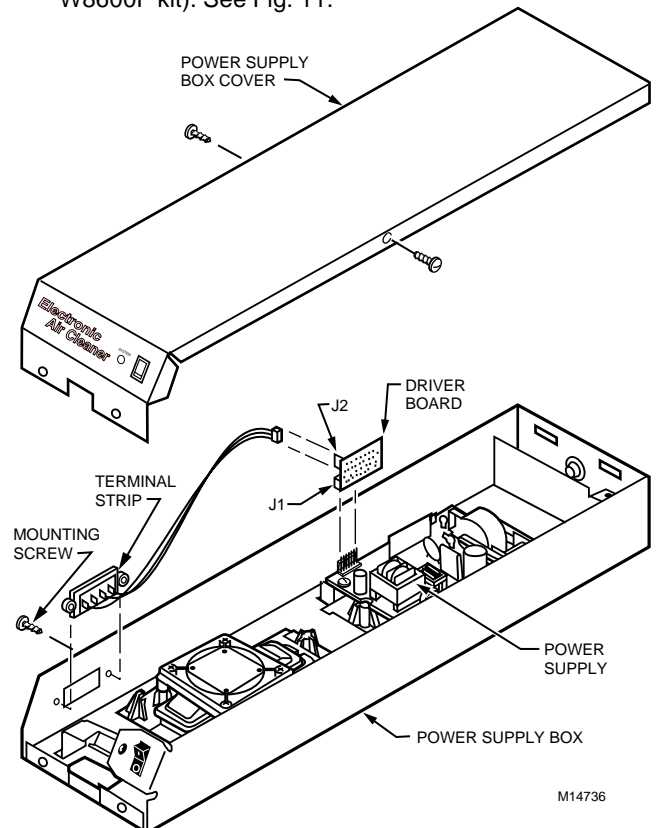

Fig. 11. Installing the driver board on the EAC.

10. Plug the driver board assembly into the J1 power supply connector.
11. Replace the power supply box cover.
12. Connect the three wires from the W8600F to the EAC terminals 1, 3 and 4. See Fig 12.

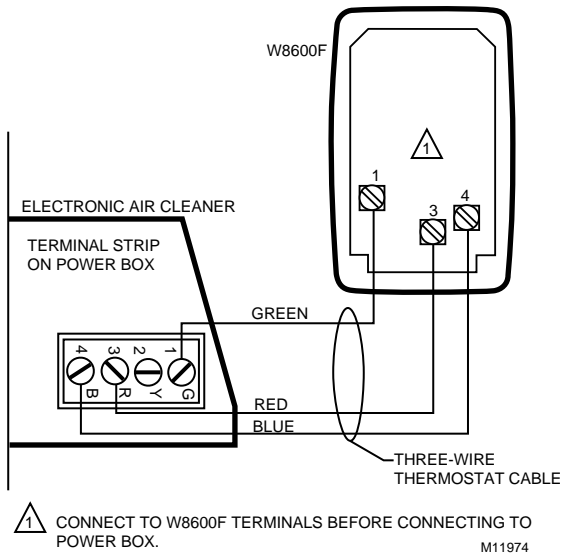

Fig. 12. Wiring W8600F to F300E power box terminal strip (two-cell model).

NOTE: Connect terminal 1 to 1, 3 to 3 and 4 to 4.

13. Turn on the EAC power.
14. Turn on the system fan.
15. Push the W8600F reset button. All four indicators on the display will flash 5 times. The ON indicator will stay active as long as the EAC and system fan are on. See Fig. 13.

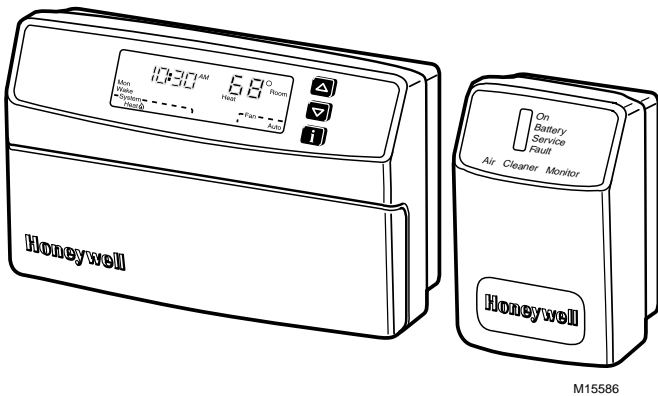

Fig. 13. Complete T8600/W8600F installation.

OR Install Optional W8600A-1007 AIRWATCH™ Indicator

The W8600A AIRWATCH Indicator is an option available for use with the F300E. It is a battery-operated timer. Installation only requires drilling holes in the wall to mount the device.

The W8600A function indicator panel has four liquid crystal display (LCD) arrow indicators that point to Battery, Air Cleaner, UV Air Treatment, and Humidifier. See Fig. 14. The blinking arrowheads indicate the devices that need service. See Table 5.

Table 5. W8600A.

LCD	If arrow is flashing or unit is beeping...	Rset by...
Battery	Batteries need changing	Changing batteries within 30 seconds of removing old batteries to maintain correct indication time.
Air Cleaner	Media filter needs replacing or electronic filter needs washing.	Pressing and holding reset button for 10 seconds or until arrow is no longer displayed.
UV Air Treatment	UV lamps need replacing in UV air treatment system.	
Humidifier	Humidifier pad needs replacing.	

NOTE: The W8600A beeps whenever an arrow is blinking to alert you to identify the device that needs service. After servicing, press the reset button at the bottom of the W8600A and hold for 10 seconds to reset the timer.

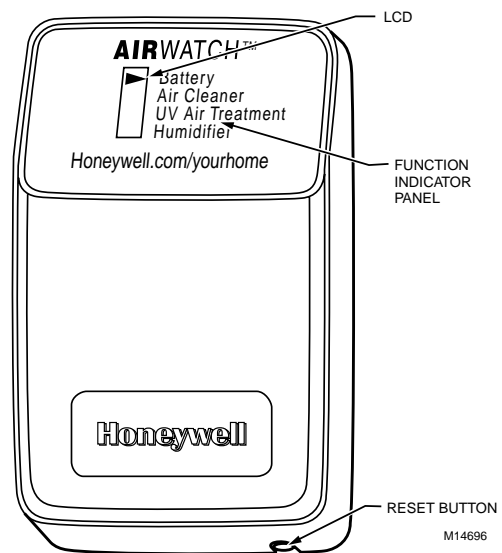

Fig. 14. W8600A AIRWATCH Indicator features.

Set DIP Switches

1. Set then DIP switches according to equipment installed in the home:
 - a. Use default position set at the factory when all devices (air cleaner, UV air treatment system, humidifier) are installed in the home.
 - b. Move DIP switch to left (off position) when a device is not installed in the home.

NOTE: The UV air treatment system and the humidifier settings are for one year. The air cleaner settings are selectable according to homeowner activities and needs.

2. Determine the air cleaner filter run time you desire and set the DIP switches accordingly:
 - a. If air cleaner filter is used, select desired filter time of 3, 6, 9 or 12 months. Follow the settings on the back of the W8600A to set the DIP switches for the desired number of months.
 - b. If air cleaner filter is not used, move the filter time DIP switches 4 and 5 to the left (off).
 - c. Use factory default settings to change the media filter or wash the electronic filter every three months.

Seal Joints

- ❑ Seal all joints in the return air system between the air cleaner and the furnace to prevent dust from entering the clean airstream. Use optional air cleaner cabinet gasket kit (part no. 32002109-001), mastic or foil tape.

Disable Unused Prefilter Guide

- ❑ Crimp the end of the downstream (closest to the furnace) prefilter guide to prevent incorrect prefilter installation following cleaning. See Fig. 15.

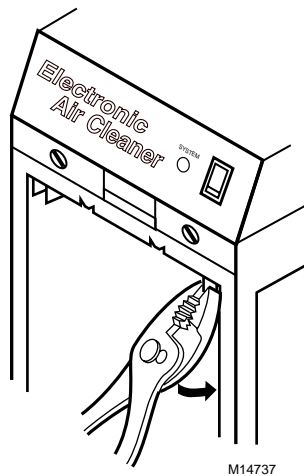

Fig. 15. Crimping prefilter guide.

Position Cell Key

The electronic cell must always be installed so the ionizer section is on the upstream side. A factory-installed cell key on the bottom of the cabinet allows the cell to be inserted in only one direction. If the arrow molded into the plastic key points in the same direction as the airflow, the ionizer will always be on the upstream side.

If the position of the key must be reversed, proceed as follows:

1. Remove the electronic cell.
2. Remove the screw holding the cell key in place. See Fig. 16.
3. Turn the key around and place it over the opposite holes. The tab on the bottom fits into the larger hole, and the screw fits into the smaller hole. Make sure the arrow on the key points in the direction of the air flow (downstream).

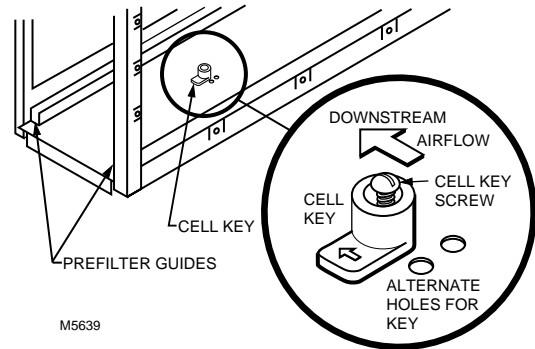

Fig. 16. Position of cell key determines orientation of cell (arrow on key must point downstream).

4. Tighten the screw into the new hole.
5. Insert the electronic cell. The ionizer section will now be on the air-entering (upstream) side of the cabinet.

Attach Cell Handle(s)

The cell handles must be installed on the end of the cell closest to the access door. To install:

1. Orient the cell as it will be when installed. The gray contact board must be toward the power supply and the airflow arrow stamped into the cell must point downstream.
2. Hold the handle sideways and insert the solid tab on the back of the handle into the slot in the cell. Turn the handle 90 degrees clockwise to align the divided tab with the square hole. See Fig. 17.

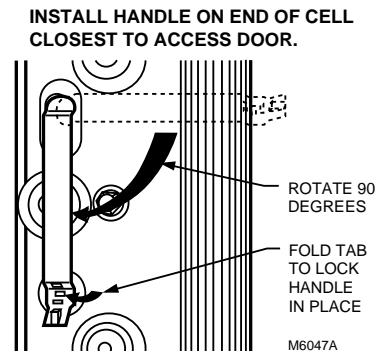

Fig. 17. Install handle on end of cell closest to access door.

3. Insert the divided tab into the square hole.
4. Fold up the wedge and insert it into the divided tab to lock the handle in place. If necessary, press with a blunt instrument like the end of a pliers.

Reassemble Air Cleaner

- ❑ Insert the electronic cell with the gray contact board toward the power supply and the airflow arrow pointing downstream. If the cell does not slide easily into the cabinet, check the orientation of the cell key.
- ❑ Insert the prefilter on the upstream side of the cabinet in the guide provided.
- ❑ Replace the access door. Insert the tab on the bottom of the door into the slot in the cabinet, then swing it closed and press into place. The door must be firmly in place or the air cleaner will not operate.

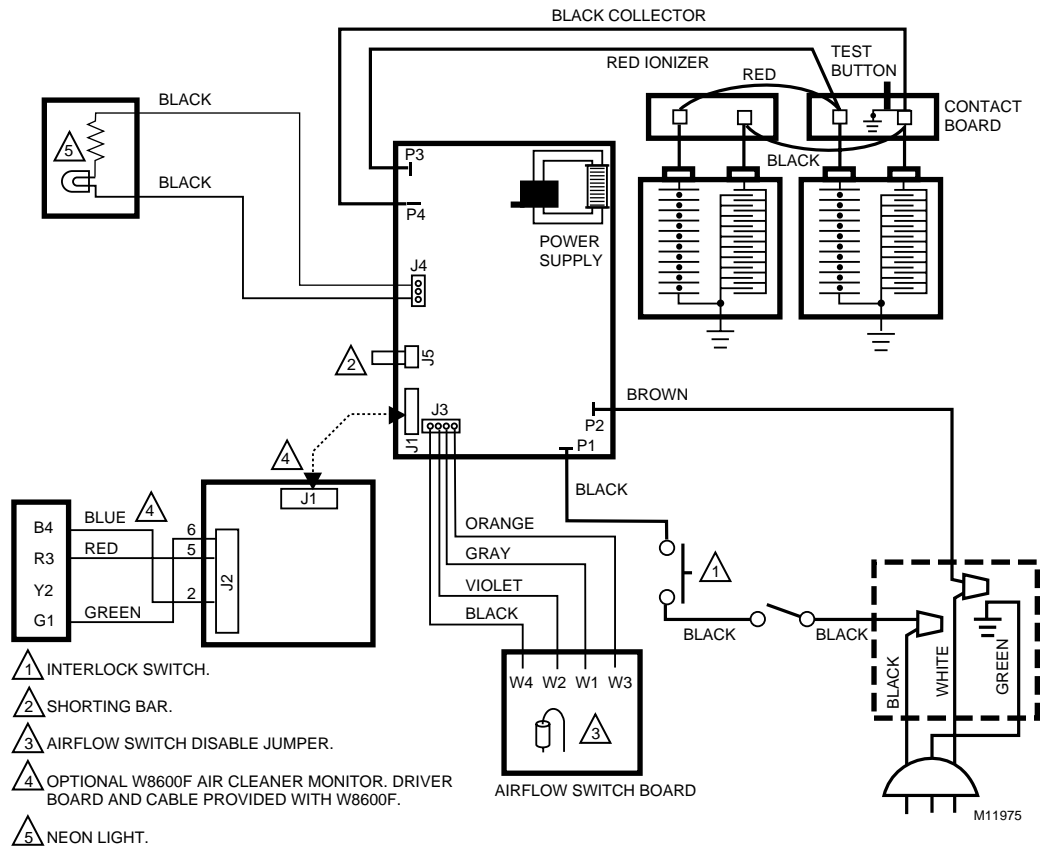

Fig. 18. Internal schematic for electronic air cleaner with W8600F.

Complete Wiring

⚠ WARNING

Electric Shock Hazard.
Can cause personal injury.
Do not use an extension cord.

- Assure all wiring complies with local codes and ordinances.
- The line voltage power source must match the voltage and frequency printed on the label inside the access door.
- When the system fan comes on the Air Flow Switch (AFS) senses the negative pressure in the duct and turns the power supply on. If power to the air cleaner is controlled by another switch, such as a sail switch or fan timer board, the AFS can be disabled by cutting the jumper on the back of the AFS circuit board. See Fig. 18.

- ❑ Plug the electronic air cleaner directly into the correct voltage and frequency outlet. See Fig. 18 for internal schematic.

NOTE: To reduce the risk of electric shock, this product has a grounding type plug that has a third (grounding) pin. This plug will only fit into a grounding type power outlet. If the plug does not fit into the outlet, contact a qualified electrician to install the proper outlet. Do not change the plug in any way.

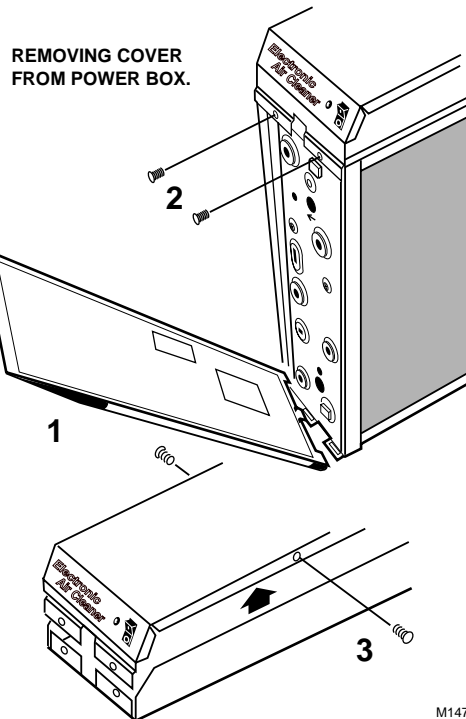

Fig. 19. Removing cover from power box.

- Alternatively, the electronic air cleaner can be wired with conduit.
 1. Open access door.
 2. Remove and retain the (2) screws from the front of the power box and the (2) screws from the sides of the power box. See Fig. 19.
 3. In the power box, remove and retain (2) wire nuts that connect the line cord leads to the power box wiring.
 4. Remove the power cord green lead from the green grounding screw on the wiring compartment barrier.
 5. Remove the power cord and the strain relief.
 6. Install the plug (provided with the literature pack) in the hole left by the power cord.
 7. Attach conduit through a power box side knockout.
 8. Wire the air cleaner directly to line voltage using wire nuts. See Fig. 20. Secure ground connection to the green ground screw on the wiring compartment barrier.
 9. Replace power supply cover and access door.

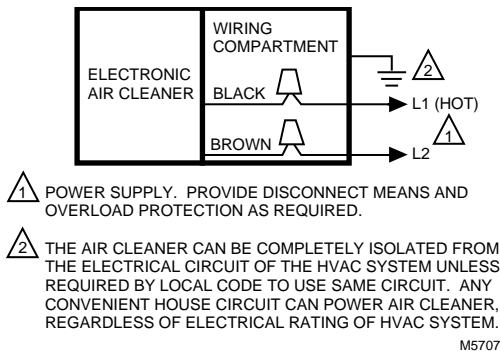

Fig. 20. Conduit connection for electronic air cleaner.

OPERATION

Large particles (lint, hair) are caught by the prefilter. As the dirty air passes through the intense high voltage electric field surrounding the ionizer wires, all particles are given an electrical charge. The air then moves through the collector part of the cell where alternate parallel plates are charged positively and negatively, creating a uniform electrostatic field. The charged particles are attracted to and collected on the plates that have the opposite electrical charge. The air leaving the air cleaner has fewer particles. Each time the air circulates through the electronic air cleaner, more particles are removed.

CHECKOUT

Inspect the Installation

Make sure:

- Turning vanes and transitions, as needed, are properly installed.
- Sheet metal joints between air cleaner and furnace are sealed.
- All sheet metal connections are complete.
- Original furnace filter has been removed and the blower compartment cleaned.
- If atomizing humidifier is installed upstream from the air cleaner, a disposable furnace filter is installed between the humidifier and the air cleaner.

- Outside air, if used, is mixed with return air or heated, as necessary, before it can reach the air cleaner.
- Airflow arrows on the electronic cell point downstream.
- Prefilter is on the upstream side of the cell.
- Cell handle faces outward.
- Electronic cell and prefilter are clean and dry.
- W8600F (if included) wiring connections are properly made.

Check Air Cleaner Operation

With all components in place, turn on the air cleaner switch and energize the system blower. Check the following points of operation:

1. The neon light next to the on-off switch is on. If a W8600F is part of the installation, also check the wall panel and make sure the ON indicator is lit. The W8600F FAULT indicator will come on if there is a problem with the high voltage power supply.
2. Turn off the system blower. The neon light should go off after a few seconds. The neon light shows that the air cleaner is energized and the high voltage power supply is working properly.
3. With a multispeed blower, repeat steps 1 and 2 for each fan speed.
4. If operation is not as described, refer to the Troubleshooting section.

SERVICE

! CAUTION

Sharp Edges.

Can cause personal injury.

Carefully handle the cell(s) or wear protective gloves to avoid cuts from the sharp metal edges.

Cleaning the Cell(s) and Prefilter(s)

To assure optimum performance from the air cleaner, the cell(s) and prefilter(s) must be cleaned regularly—every one to six months. Washing frequency will vary depending on the number of family members, pets, activities (such as cooking or woodworking) and smoking habits. Use the wash reminder schedule on the last page of this document to help establish and maintain a regular cleaning schedule. Keep your wash reminder schedule in a convenient location.

If the air cleaner has a W8600F Air Cleaner Monitor the SERVICE indicator will activate to indicate that it is time to wash the prefilter(s) and cell(s). The time between activation of the SERVICE indicator is based on air cleaner run time that is selected by the installer at installation. See W8600F installation instructions, page 8, for instructions on selecting air cleaner run time. Pressing the Reset button on the bottom right corner of the housing resets the W8600F SERVICE indicator. See Fig. 8.

If the air cleaner has a W8600A AIRWATCH Indicator, the Air Cleaner LCD arrow will blink to indicate it is time to wash the prefilter(s) and cell(s). The time between activation of the Air Cleaner LCD is based on air cleaner run time that is selected at installation. See Set DIP Switches section in the W8600A installation instructions for information on selecting air cleaner run time. After servicing the filters, press and hold the reset button for 10 seconds or until the LCD arrow is no longer displayed to reset the W8600A AIRWATCH Indicator.

NOTE: To let the heating or air conditioning system operate normally while the cell(s) are being washed, simply turn off the air cleaner switch.

Vacuum the prefilter or brush, or soak it in a tub. Do not wash the prefilter in the dishwasher or car wash.

Automatic Dishwasher

CAUTION

Burn Hazard.

Can cause personal injury.

Allow the cell(s) to cool completely in the dishwasher at the end of the wash cycle or wear protective gloves to avoid burns. Hot water can accumulate in the tubes supporting the collector plates. Tip the cell(s) so these tubes will drain.

Record wash times on the chart on last page.

IMPORTANT

- Check the dishwasher owner's manual. Some manufacturers do not recommend washing electronic cell(s) in their dishwashers.
- If the dishwasher has upper and lower arms, position the cell(s) carefully to allow good water circulation.
- Be careful to avoid damaging the cell(s) when placing them in the dishwasher. Broken ionizer wires or bent collector plates are not included in the warranty.
- Very dirty cell(s), especially from tobacco or cooking smoke, can discolor the plastic parts and the lining of some dishwashers. This discoloration is not harmful. To minimize it, wash the cell(s) more frequently or try a different brand of detergent.
- **Do not allow the dishwasher to run through the dry cycle.** This will bake on any contaminants not removed during the wash cycle and reduce air cleaner efficiency.

1. Put the cell(s) on the lower rack of the dishwasher with the airflow arrow pointing up. It may be necessary to remove the upper rack. Do not block water flow to the upper arm.

HINT: Lay a few large water glasses between the spikes on the lower rack and rest the cell(s) on them so the spikes do not damage the aluminum collector blades.

2. Using regular dishwashing detergent, allow the dishwasher to run through the complete wash and rinse cycle. **Do not use the dry cycle.** To avoid burns, let the cell(s) cool completely before removing, or wear protective gloves when removing the cell(s). Remember that water may be trapped inside the cell(s). Tip the cell(s) so the tubes can drain.
3. Wipe the ionizer wires and contact board on the end of the cell using thumb and forefinger with a small, damp cloth.
4. Inspect the dishwasher. Rerun the wash and/or rinse cycle with the dishwasher empty if there is dirt or residue from washing the cell(s). If dirt or residue seems excessive, wash the cell(s) more often or try a different detergent.

Washing the Cell(s) in a Container

CAUTION

Hazardous Chemical.

Can cause personal injury.

- Do not splash the detergent solution in eyes. Wear rubber gloves to avoid prolonged detergent contact with skin.
- Keep detergent and solution out of reach of children.

NOTE: Always wash the cell(s) first, then the prefilter(s), to keep heavy prefilter lint from getting caught in the cell(s).

1. Use a large enough container, such as a laundry tub or trash container, to hold one or both cell(s).

NOTE: Sharp corners on the cell(s) can scratch the surface of a bathtub.

2. Dissolve about 3/4 cup of automatic dishwasher detergent per cell in enough hot water to cover the cell(s). If the detergent does not dissolve readily, or forms a scum on the water, try another brand, or use softened water.
3. After the detergent has completely dissolved, place the cell(s) in the container and let soak for 15 to 20 minutes. Agitate up and down a few times, and remove. See Fig. 21.
4. Next, wash the prefilter(s) the same way. Empty and rinse the wash container.

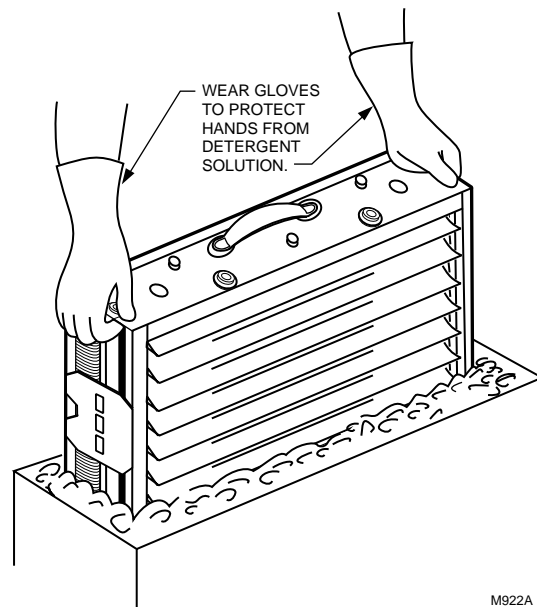

Fig. 21. Washing cell(s) in container.

5. Rinse the cell(s) and prefilter(s) with a hard spray of very hot water; rinse the tub clean, then fill the tub with clean hot water and soak for 5 to 15 minutes. Rinse until the water draining from the cell(s) and prefilter(s) no longer feels slippery.
6. Soak cell(s) and prefilter(s) in a final clear water rinse for ten minutes.
7. Wipe the ionizer wires and contact board on the end of the cell using your thumb and forefinger with a small, damp cloth.

Reinstall the Cell(s) and Prefilter(s)

1. Inspect the cell(s) for broken ionizer wires and bent collector plates. Repair as necessary or take to a Honeywell Authorized Air Cleaner Repair Station.
2. Slide the prefilter(s) into the upstream prefilter guides.
3. Slide in the air cleaner cell(s) so the airflow arrow points downstream and the handle(s) faces outward.
4. Firmly close the access door.
5. Turn on the air cleaner. If the cell(s) and prefilter(s) are wet, the neon light may not come on and you may hear arcing. If the arcing is annoying, simply turn off the air cleaner for two to three hours or until the cell(s) is dry.

If the air cleaner has an Air Cleaner Monitor, the FAULT indicator may activate when the cell(s) and prefilter(s) are wet. Again, if the FAULT indicator is annoying, simply turn off the air cleaner for two to three hours or until the cell(s) and prefilter(s) are dry.

Replacing Ionizer Wires

Broken or bent ionizer wires can cause an electrical short to ground, often resulting in visible arcing or sparking. Do not use cell(s) until broken wires are removed. Cells can be used temporarily with one wire missing, but replace the wire as soon as possible.

Replacement wires are supplied cut to length with eyelets on both ends for easy installation. See Parts and Accessories not illustrated on Page 18 for Part No. To install:

1. Hook the eyelet on one end of the wire over the spring connector on one end of the cell. See Fig. 23. Be careful to avoid damaging the spring connector or other parts of the cell.
2. Hold the opposite eyelet with a needle nose pliers and stretch the wire the length of the cell. Depress the opposite spring connector and hook the eyelet over it.
3. Check the cell for short circuits using an ohmmeter. Check the resistance between the frame of the cell and both the ionizer and the collector contacts. In each case, the resistance should be infinite. See Fig. 24.

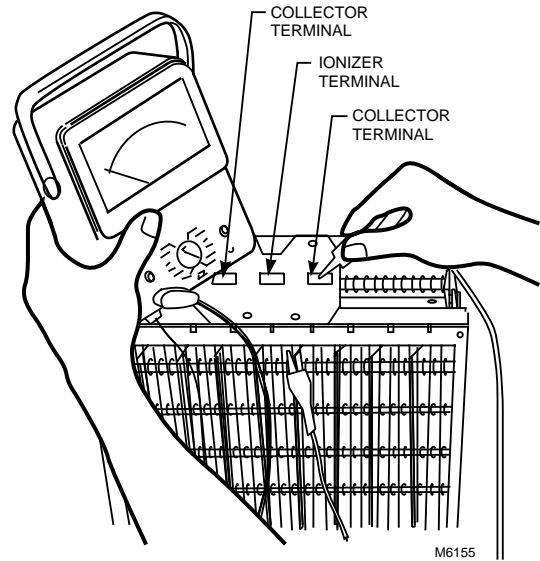
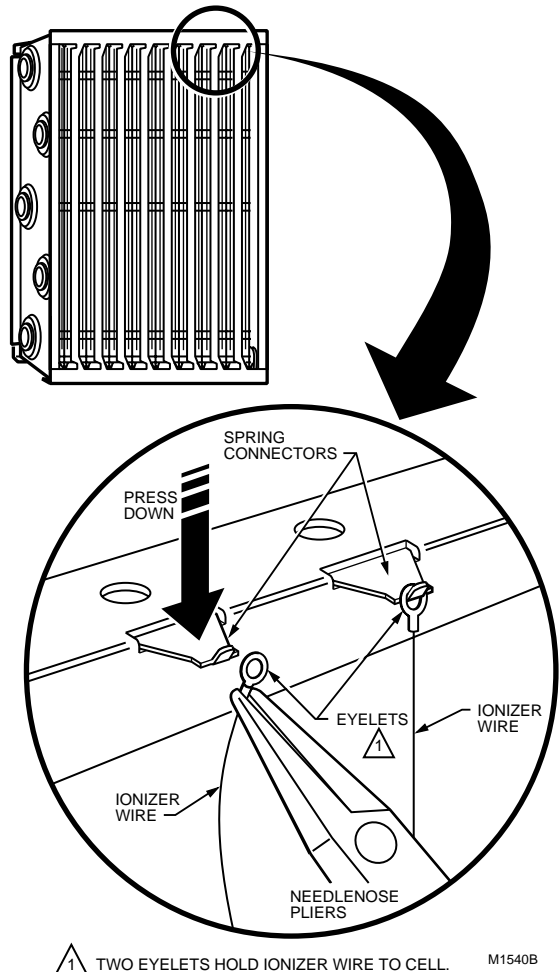

Fig. 22. Use ohmmeter to check electronic cells for short circuits.

REPLACING AN IONIZER WIRE.



⚠ TWO EYELETS HOLD IONIZER WIRE TO CELL.

Fig. 23. Replacing an ionizer wire.

Modification to Reduce Ozone Odor

WARNING

**Electric Shock Hazard.
Can cause personal injury.**

Always disconnect power and open the access door before opening the power supply cover.

The electronic air cleaner generates a small amount of ozone in normal operation. During the first week or two of operation, the amount may be higher because of sharp edges on some of the new high voltage metal parts. Normal use quickly dulls these edges.

The average person can detect the odor of ozone in concentrations as low as 0.003 to 0.010 parts per million (ppm). The electronic air cleaner contributes 0.005 to 0.010 ppm of ozone to the indoor air. The U.S. Food and Drug Administration and Health and Welfare Canada recommend that indoor ozone concentration should not exceed 0.050 ppm. As a comparison, the outdoor ozone level in major cities is sometimes as high 0.100 ppm.

However, if desired, the ozone generated by the air cleaner can be reduced in one of two ways:

1. Install an activated carbon filter downstream from the air cleaner. Make sure particles from the air filter cannot fall into the air cleaner.

WARNING

**Electric Shock Hazard.
Can cause personal injury.**

Only a trained service technician should perform the following procedure.

2. This will reduce ozone production about 20 to 25 percent and reduce efficiency about seven to ten percent, depending on actual airflow delivered by the furnace blower.
 - a. Unplug or disconnect power supply to the air cleaner.
 - b. Open the access door.
 - c. Remove the power box cover. See Fig. 25.
 - d. Locate J5 shorting bar on the power supply. See Fig. 26. Remove the shorting bar and reinstall on only one pin.

NOTE: The ozone will be reduced, but the shorting bar is available for reinstallation if needed.

- e. Replace the power supply cover and access the door. Turn on the power.
- f. Repeat the checkout procedure before leaving the job.

REMOVE POWER BOX FROM AIR CLEANER AND REMOVE THE COVER.

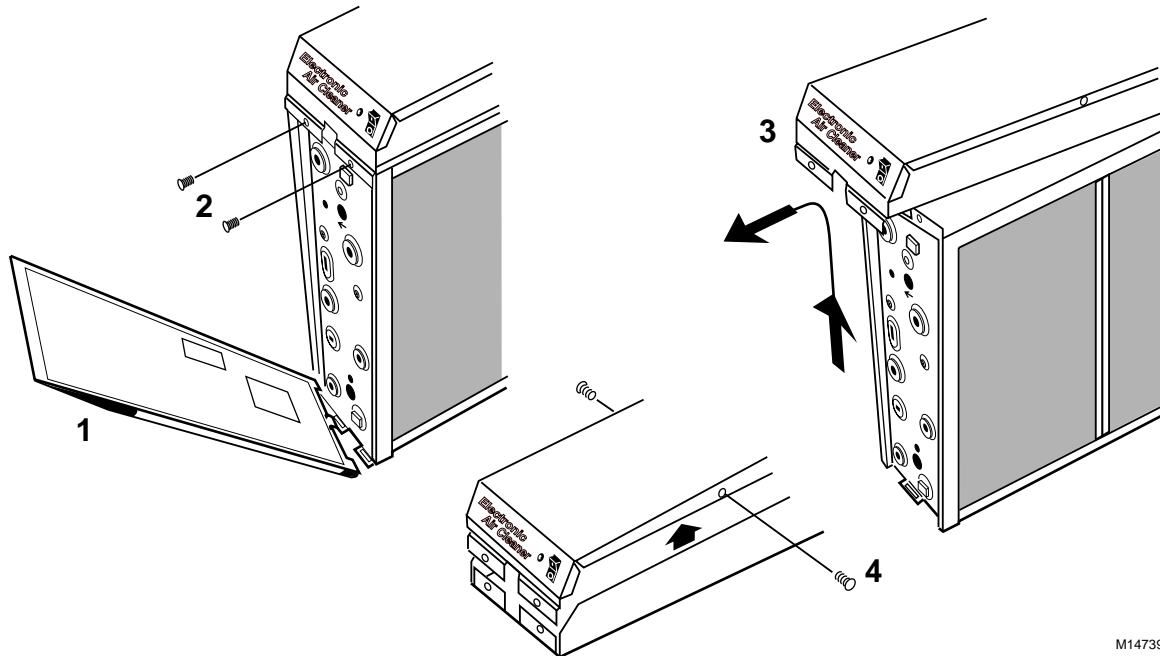

M14739A

Fig. 24. Remove power box from air cleaner and remove cover.

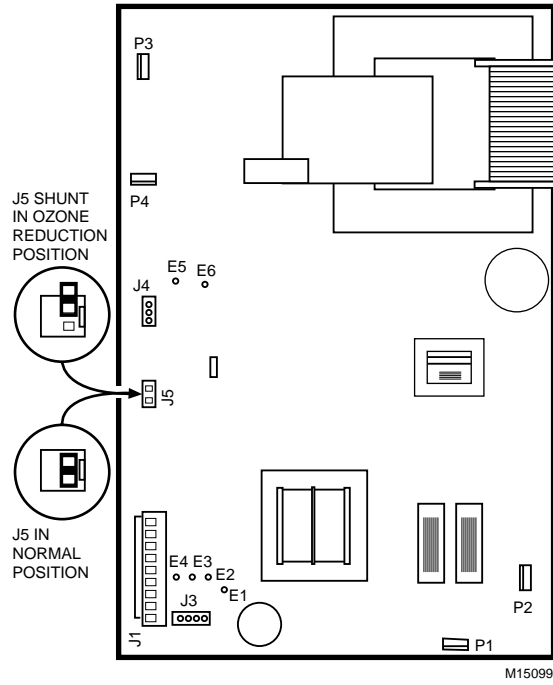

Fig. 25. Move J5 shorting bar to reduce ozone production about 20 to 25 percent.

REPLACEMENT PARTS/EXPLODED VIEW

No.	Description	Nominal Return Air Opening			
		16 x 20 in. (406 x 508 mm)	16 x 25 in. (406 x 635 mm)	20 x 20 in. (508 x 508 mm)	20 x 25 in. (508 x 635 mm)
1	Access Door	32004876-004	32004876-004	32004876-003	32004876-003
2	Electronic Cell	FC37A1114 (2)	FC37A1130 (2)	FC37A1049 (2)	FC37A1064 (2)
3	Cell Handle	137266 (2)	137266 (2)	137266 (1)	137266 (2)
4	Prefilter	209989 (2)	203371 (2)	203373(2)	203372 (2)
5	Cell Key	136518 (1)	136518 (1)	136518 (1)	136518 (1)
6	Power Box Assembly Includes No. 8-20, 120V, 60 Hz	208418E (1)	208417B (1)	208418A (1)	208417A (1)
	240V, 60 Hz ^a	N/A	N/A	N/A	N/A
7	Switch	203321 (1)	203321 (1)	203321 (1)	203321 (1)
8	Power Box Cover and Label	32004930-002	32004930-001	32004930-002	32004930-001
9	Power Supply, 120V, 60 Hz	208414G (1)	208414B (1)	208414B (1)	208414A (1)
	240V, 60 Hz ^a	N/A	N/A	N/A	N/A
10	Interlock Bracket and Switch	4074ETG (1)	4074ETG (1)	4074ETG (1)	4074ETG (1)
11	W8600 Terminal Strip	Supplied with W8600F			
12	Terminal Board Assembly Front	203329B (1)	203329B (1)	203329C (1)	203329B (1)
13	Terminal Board Assembly Rear	203329A (1)	203329A (1)	203329A (1)	203329A (1)
14	Barrier Plate	203331 (1)	203331 (1)	203331 (1)	203331 (1)
15	Strain Relief	203852 (1)	203852 (1)	203852 (1)	203852 (1)
16	Line Cord	4074ETD (1)	4074ETD (1)	4074ETD (1)	4074ETD (1)
17	Hole Plug	203847 (1)	203847 (1)	203847 (1)	203847 (1)
18	Neon Assembly	4074EYS (1)	4074EYS (1)	4074EYS(1)	4074EYS (1)
19	Airflow Switch	4074ETH (1)	4074ETH (1)	4074ETH (1)	4074ETH (1)
20	FC37A Bag Assembly for cell repair. Contains 2 Connector Clips, 1 Terminal Board and Instructions.	4074EHG	4074EHG	4074EHG	4074EHG

(#) = Quantity required per unit N/A = Not available as merchandized part.

^a Use 203365A Conversion Kit for changing 120V, 60 Hz power supply to 240V, 60 Hz or 220V/240V, 50 Hz.

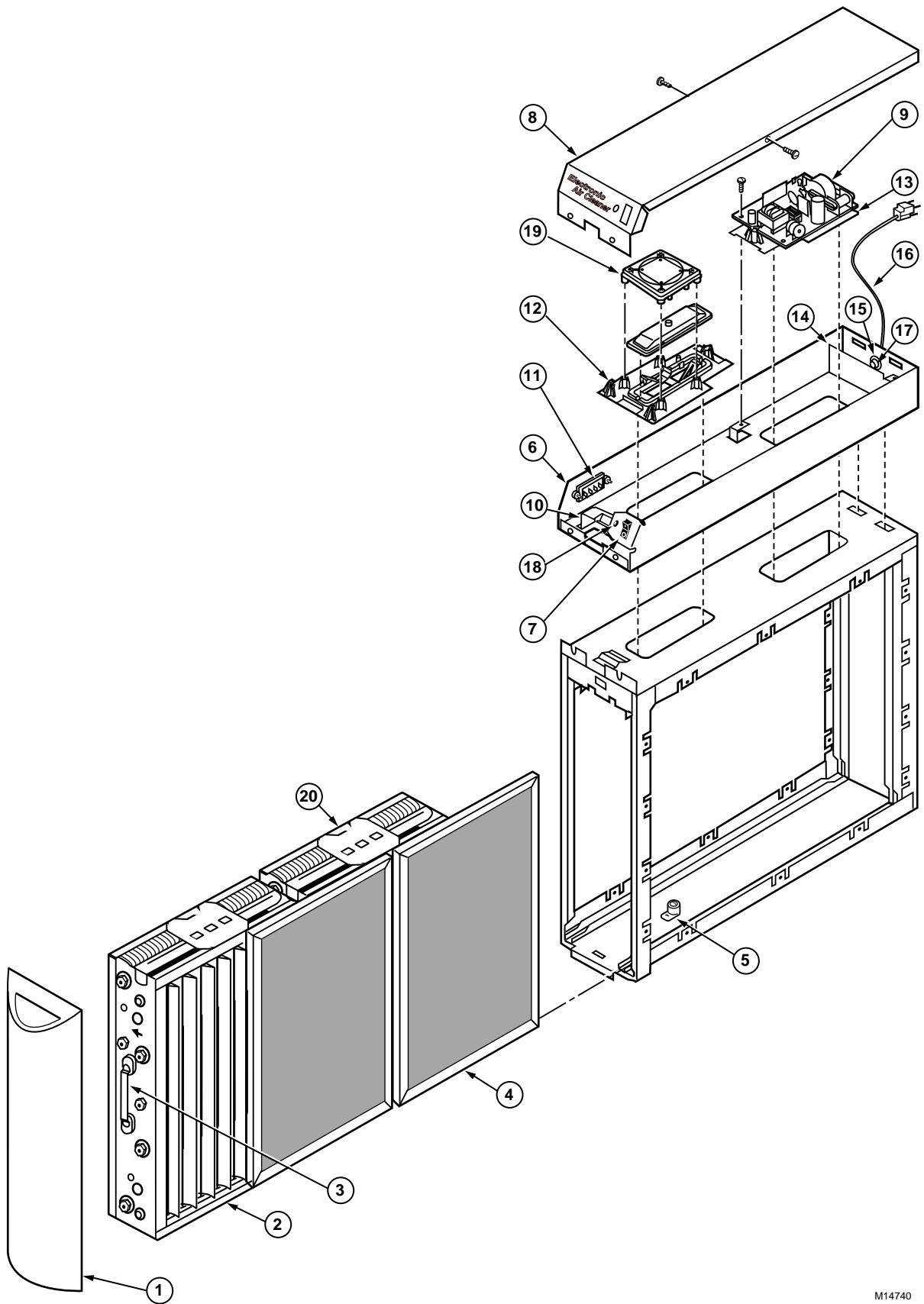

M14740

Fig. 27. Components of the Electronic Air Cleaner (2-cell model shown).

Parts and Accessories Not Illustrated

Description	Nominal Return Air Opening			
	16 x 20 in. (406 x 508 mm)	16 x 25 in. (406 x 635 mm)	20 x 20 in. (508 x 508 mm)	20 x 25 in. (508 x 635 mm)
Air Cleaner Cabinet Gasket Kit	32002109-001	32002109-001	32002109-001	32002109-001
Ionizer Wires (multiples of 5)	136434BA	136434BA	136434AA	136434AA
Mounting Screws	136375 (6)	136375 (6)	136375 (6)	136375 (6)
Air Cleaner Monitor (beige color)	W8600F1008	W8600F1008	W8600F1008	W8600F1008
Premier White® AIRWATCH® Indicator	W8600A1007	W8600A1007	W8600A1007	W8600A1007
Premier White® Air Cleaner Monitor	W8600F1014	W8600F1014	W8600F1014	W8600F1014
2-Stage EAC Cell with Collector Clip	N/A	FC37A1247 (2)	N/A	FC37A1239 (2)
240V Conversion Kit	203365A	203365A	203365A	203365A

(#) = Quantity required per unit N/A = Not available as merchandized part.

ELECTRICAL TROUBLESHOOTING

WARNING

Electric Shock Hazard.
Can cause personal injury or equipment damage.
The following procedures expose hazardous live parts. Disconnect from power between checks and proceed carefully. These instructions are for use by qualified personnel only.

Tools and Equipment

- Troubleshooting the electronic air cleaner requires:
- Needle nose pliers for stringing ionizer wires and inserting edge connectors.
 - Test meter.

Neon Light (On Power Box)

The neon light is powered through the power supply and is on when the power supply output voltage is normal.

FAULT Indicator (Air Cleaners with W8600F)

The FAULT indicator is on the W8600F. It activates to indicate the following conditions: excessive dirt loading, partial shorting of the collector, continuous ionizer or collector arcing, power supply failure, excessive ionizer current, or any condition causing a major reduction in high voltage.

Power Box

WARNING

Electric Shock Hazard.
Can cause personal injury.
Always turn off power and remove access door before removing power supply or its cover.

The solid state power supply within the power supply box can be replaced. When troubleshooting indicates a power supply problem, replace the entire power box or replace the power supply within the box. See Installation Instructions. See Fig. 24 for power box removal.

Troubleshooting Procedure

The electronic air cleaner Troubleshooting charts show how to quickly isolate a problem in the air cleaner. Although a meter is needed for some steps, the primary diagnostic tool is the neon light. See Fig. 28.

TROUBLE SHOOTING AIR CLEANERS WITH PERFORMANCE INDICATOR.

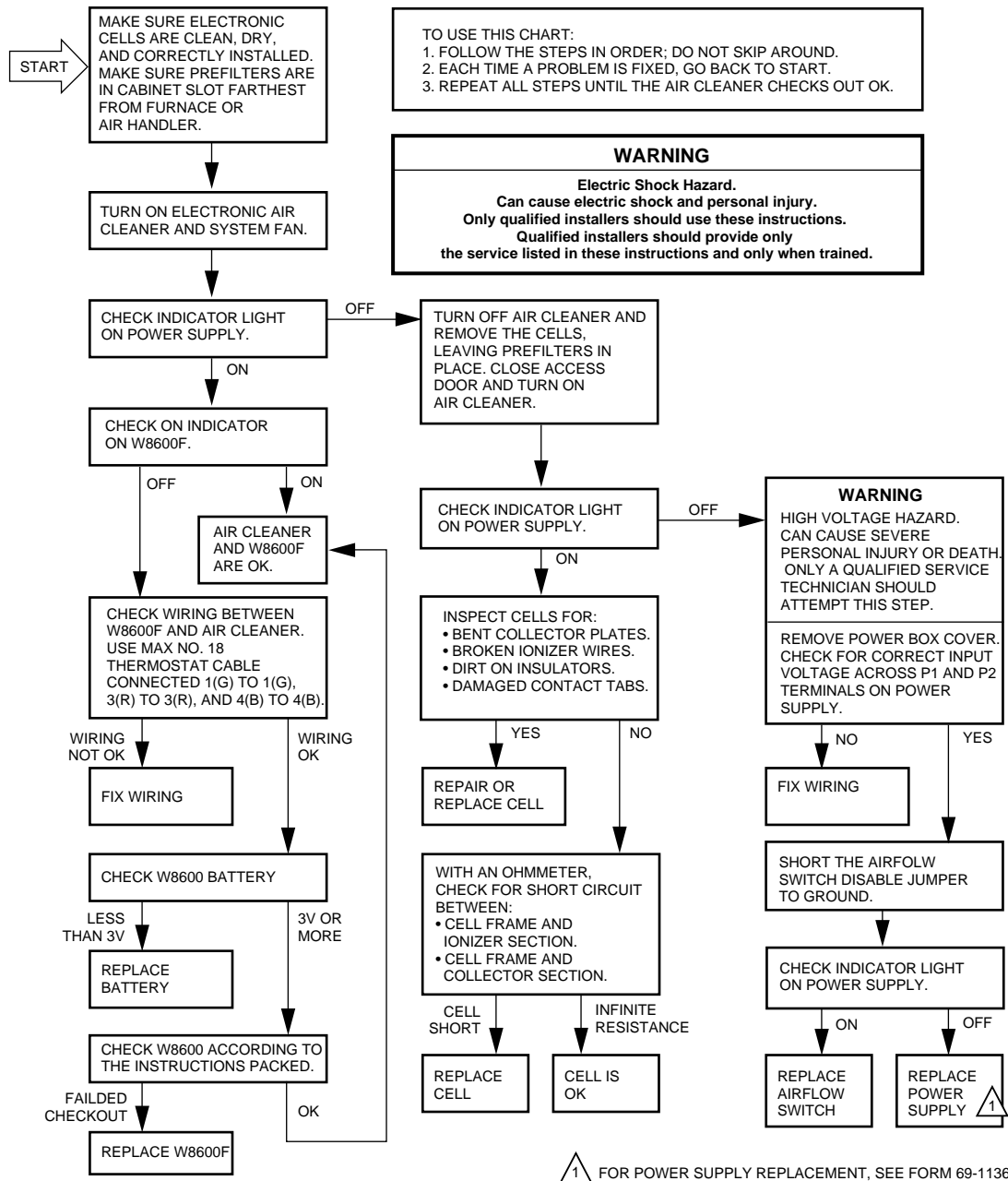

M14741

Fig. 28. Troubleshooting air cleaners.

**IMPROVE YOUR INDOOR AIR WITH A COMPLETE
Whole House Air Quality System by Honeywell**



ULTRAVIOLET AIR TREATMENT SYSTEM

ZAP

- ZAP airborne germs.
- Kill most germs before they recycle through your home.
- Prevent mold spores from growing on your system cooling coils.



F300E ELECTRONIC AIR CLEANER

TRAP

- TRAP airborne particles.
- Up to 99% efficient at capturing airborne particles.
- Effectively REDUCES fungi, bacteria, mold antigen, cat antigen and ragweed pollen antigen that pass through system.



ENVIRACAIRE ELITE HUMIDIFIERS

MOISTURIZE

- Moisturize parched air.
- Help maintain proper humidity to minimize adverse health effects.
- Features special antimicrobial agent to prevent surface growth and migration of bacteria, mold, fungus and algae on the humidifier pad.



Honeywell offers one of the broadest families of home solutions in the industry - ranging from thermostats, zoning, ventilation, air cleaning, humidification to internet-enabled home control and wireless WebPAD™ devices for web surfing and more!! Check out our offerings on-line at www.honeywell.com/yourhome/ ... only from Honeywell.



M14757

Home and Building Control
Honeywell
1985 Douglas Drive North
Golden Valley, MN 55422

Home and Building Control
Honeywell Limited-Honeywell Limitée
35 Dynamic Drive
Scarborough, Ontario
M1V 4Z9

Honeywell

