

OpenAir™ Electronic Damper Actuator GDE/GLB Rotary Non-spring Return

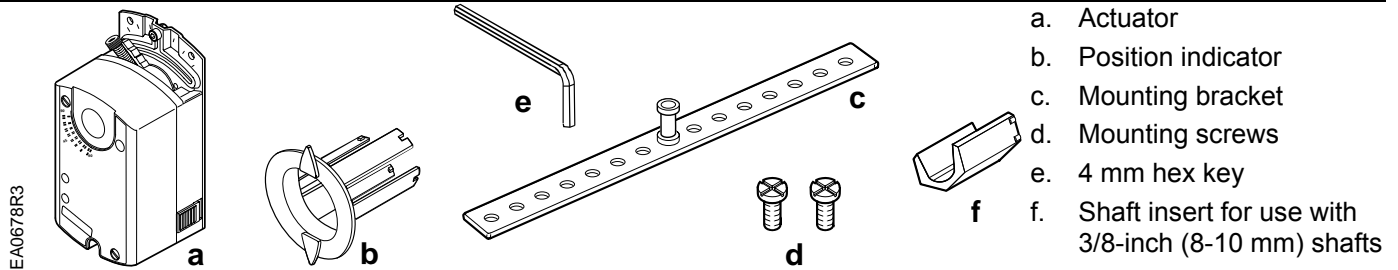

Figure 1. Parts of the GDE/GLB Rotary Actuator.

Product Description

Steps for direct-coupled mounting of the OpenAir GDE/GLB Series non-spring return rotary electronic damper actuator.

Product Numbers

GDE131.1U	GLB131.1P
GDE131.1U/B (24 pk)	GLB132.1P
GDE131.1P	GLB136.1P
GDE131.1P/B (24 pk)	GLB161.1P
GDE131.1Q/B 6-ft cable (12 pk)	GLB163.1P
GDE132.1P	GLB164.1P
GDE136.1P	GLB166.1P
GDE161.1P	
GDE161.1P/B (24 pk)	
GDE163.1P	
GDE164.1P	
GDE166.1P	

Required Tools

- 4 mm hex wrench
- 4 mm (5/32-inch) drill bit and drill
- Small flat-blade screwdriver
- Marker or pencil

Estimated Installation Time

30 minutes

Warning/Caution Notations

WARNING :		Personal injury/loss of life may occur if you do not follow a procedure as specified.
CAUTION:		Equipment damage or loss of data may occur if you do not follow a procedure as specified.

Instructions



WARNING:

Do not open the actuator.

NOTE: Place the actuator on the damper shaft so that the front of the actuator is accessible. The label is on the front side.

1. Determine whether the damper blades will rotate clockwise or counterclockwise to open. See Figure 2.
2. If the blades will rotate counterclockwise, slide the manual override switch to manual, and move the adjustment lever to the right. Return the switch to automatic. See Figure 9.

To mount a (modulating) GDE/GLB16x, set the Dual In-line Package (DIP) switches to the required positions.

1. To access the DIP switches, raise the tab on the lower left side of the actuator. See Figure 2. The factory setting is clockwise (middle switch), with a direct-acting feedback signal (right switch).
2. Close the tab over the DIP switches.

To mount a (3-position) GDE/GLB13x for counterclockwise rotation, follow the *Counterclockwise Damper Rotation* instructions located in the *Wiring Diagrams* section when wiring the actuator to the controller.

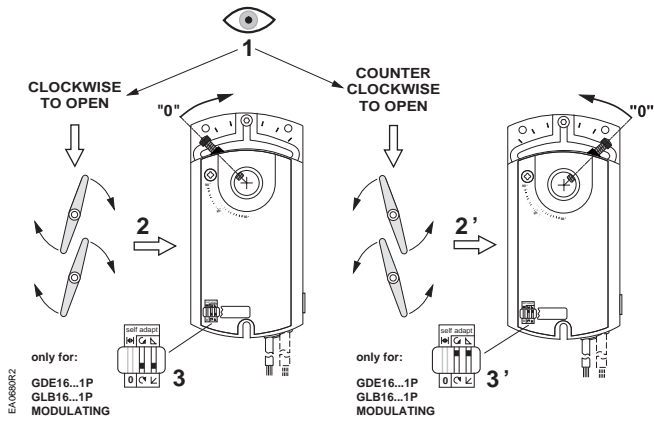

Figure 2. Setting the Direction of Rotation.

NOTE: For DIP switch setting options, see the *Technical Instructions EA GDE/GLB-1* (155-187P25).

Mounting and Installation

NOTE: The GDE/GLB actuator comes with a factory installed 1/2-inch shaft guide. If shaft size is 1/2-inch, proceed with Figure 6.

When using a 3/8-inch shaft: Remove factory installed 1/2-inch guide. See Figure 3.

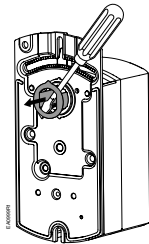

Figure 3. Removing 1/2-inch Ø shaft guide for 3/8-in or 5/8-in shaft.

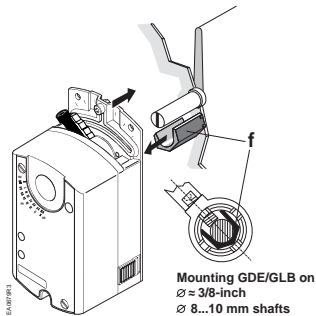

Figure 4. 3/8 Ø inch shaft, see Figure 1 Item f.

1. A 3/8-inch shaft adapter is provided in actuator package.
2. Hold the shaft insert so that the raised tabs are inserted last when placing the insert into the back of the actuator.
3. Proceed to Figure 6.

When using a 5/8-inch shaft:

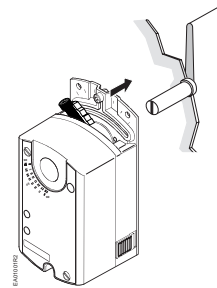

Figure 5. 5/8 Ø inch shaft.

1. Remove factory installed 1/2-inch guide. See Figure 3.
2. Mount actuator to shaft per Figure 6.

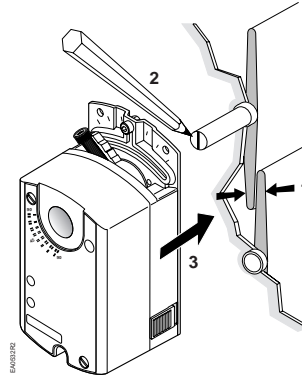

Figure 6. Mounting Actuator to Damper Shaft.

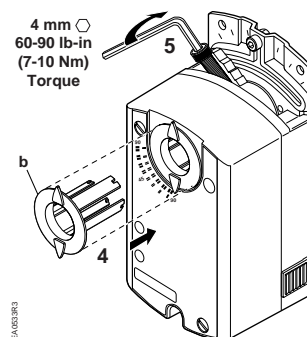

Figure 7. Installing the Position Indicator (b).

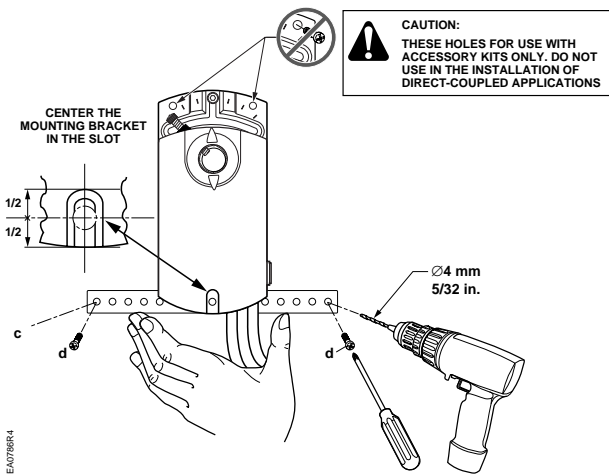

Figure 8. Attaching the Mounting Bracket.

Manual Override

To move the damper blades and lock the position with no power present, do the following:

1. Slide the red manual override knob toward the back of the actuator. See figure 9.
2. Make adjustments to the damper position.
3. Slide the red manual override knob toward the front of the actuator.

Once power is restored, the actuator returns to automated control.

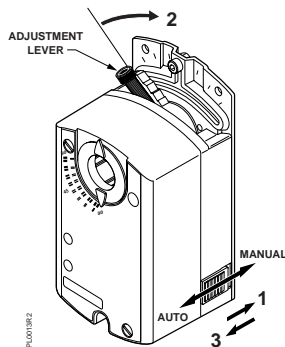

Figure 9. Manual Override.

Dual Auxiliary Switch Setting

For GDE/GLB 136x, GDE/GLB164x and GDE/GLB166x only.

Factory setting: A = 5° B = 85°

Use a flat-blade screwdriver to adjust the A switch. The long arm of the † points to the setting. Manually turn the red ring of the B switch. The narrower tab on the ring points to the setting. See Figure 10.

The auxiliary switch setting shafts rotate with the actuator.

NOTE: The scale is valid only when the actuator is in the "0" position on clockwise motion.

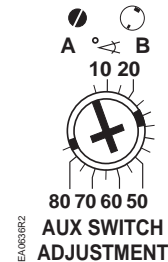

Figure 10. Auxiliary Switch Setting Dial.

Mechanical Range Adjustment

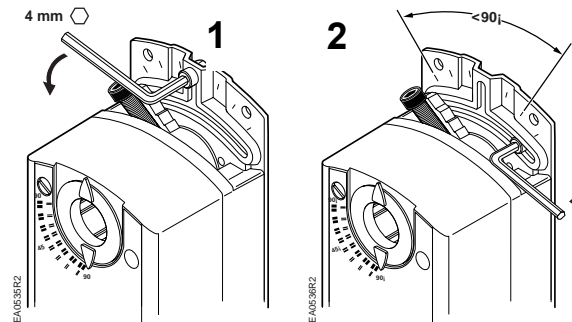

Figure 11. Moving the Mechanical Range Stop.

1. Loosen the stop set screw.
2. Move it along the track to the desired position, and fasten it in place.

Mechanical Range Limitation and Self-adapt Feature

1. To use the entire 0 to 10V input signal to control the adjusted range, raise the tab located on the lower left-hand side of the actuator and locate the DIP switches. See Figure 12.
2. Set the self-adapt DIP switch to (ON).
3. Close the tab over the DIP switches.

For example, if you set the locking screw at 70° and turn the self-adapt switch ON, a 5V input signal will drive the damper to 35° (50% of its adjusted range).

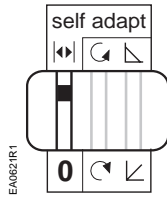

Figure 12. Self-adapt Switch in the On Position.
 Factory setting 0 (OFF)



CAUTION:

When turning the self-adaptive feature on, or after software reset with the feature on, the actuator will enter a five-minute calibration cycle as the actuator adjusts to the rotation limits of the system. The software reset happens after power on, or may be caused by electrostatic discharge (ESD) at levels of 2 kV and above.

Slope (span) and Offset adjustment

For GDE/GLB163x and GDE/GLB164x only

Factory setting:
 Slope (span) $\Delta U \approx 10$
 Offset $U_o = 0$

Use a flat-blade screwdriver to make adjustments. The long arm of the \dagger points to the setting.



Figure 13.

Wiring

All wiring must conform to NEC and local codes and regulations.

Use earth ground isolating step-down Class 2 transformers. Do not use autotransformers.

Determine the supply transformer rating by summing total VA of all actuators used. It is recommended that one transformer power no more than 10 actuators.



WARNING:

Installations requiring CC Conformance

- All wiring for CE rated actuators must only be separated extra low voltage (SELV) or protective extra low voltage (PELV) per HD384-4-41.
- Use safety-isolating transformers (Class III transformer) per EN 61558. They must be rated for 100% duty cycle.
- Overcurrent protection for supply lines is maximum 10A.

Wiring Diagrams

GDE/GLB13x

Counterclockwise Damper Rotation of GDE/GLB13x

If the damper blades turn counterclockwise to open (CCW), reverse the 6 (violet) and 7 (orange) wires at the controller.



CAUTION:

Do not wire different types of actuators (such as GBB or GIB actuators) in parallel with these models.

GDE/GLB13x, Continued

24 Vac power supply 3-position control.

Each wire has the standard symbol printed on it. See Table 1.

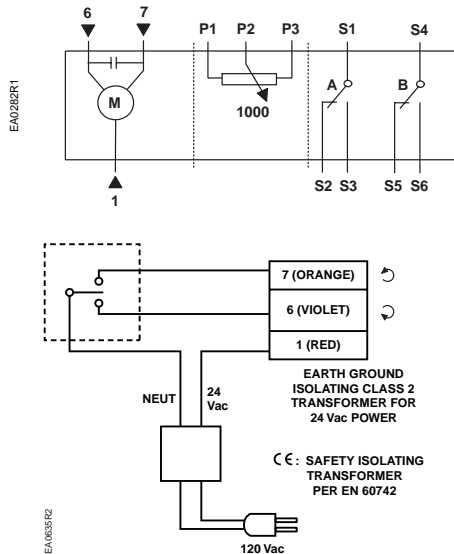

Figure 14. 3-position Control.

GDE/GLB16x

24 Vac power supply 0 to 10V modulating control

Each wire has the standard symbol printed on it. See Table 2.

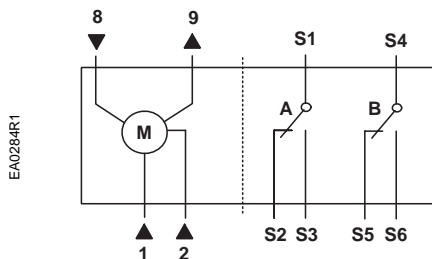

Figure 15. 0 to 10V Modulating Control.

Table 1. 3-position Control 24 Vac.

Standard Symbol	Function	Terminal Designation	Color	
			Standard	Plenum
1	Supply (SP)	G	Red	Red
6	Control signal clockwise	Y1	Violet	Violet
7	Control signal counterclockwise	Y2	Orange	Orange
Factory installed options				
S1	Switch A Common	Q11	Gray/red	Black
S2	Switch A N.C.	Q12	Gray/blue	Black
S3	Switch A N.O.	Q14	Gray/pink	Black
S4	Switch B Common	Q21	Black/red	Black
S5	Switch B N.C.	Q22	Black/blue	Black
S6	Switch B N.O.	Q24	Black/pink	Black
P1	Feedback Potentiometer 0 to 100% P1 - P2	a	White/red	Black
P2	Feedback Potentiometer Common	b	White/blue	Black
P3	Feedback Potentiometer 100 to 0% P3 - P2	c	White/pink	Black

Table 2. Modulating Control.

Standard Symbol	Function	Terminal Designation	Color
1	Supply (SP)	G	Red
2	Neutral (SN)	G0	Black
8	0 to 10V input signal	Y	Gray
9	Output for 0 to 10 Vdc position indication	U	Pink

Factory installed options

S1	Switch A – Common	Q11	Black
S2	Switch A – N.C.	Q12	Black
S3	Switch A – N.O.	Q14	Black
S4	Switch B – Common	Q21	Black
S5	Switch B – N.C.	Q22	Black
S6	Switch B – N.O.	Q24	Black

Dimensions

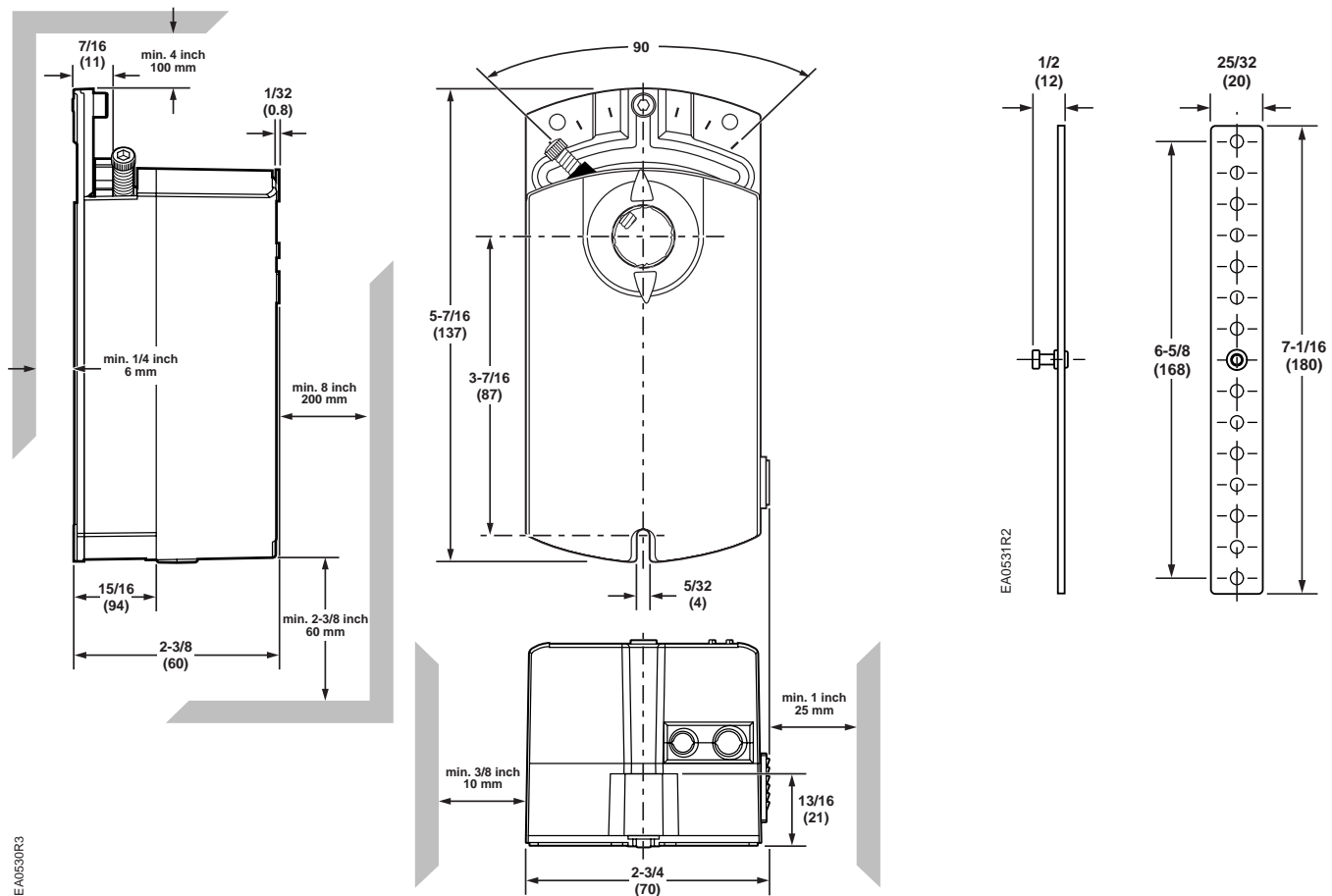

Figure 16. Dimensions of the OpenAir GDE/GLB Actuator and Mounting Bracket.

References

- EA GDE/GLB-1 155-187P25
 OpenAir™ Electronic Damper Actuators
 GDE/GLB Series Non-spring Return Rotary
 24 Vac Modulating Control
- EA GDE/GLB-2 155-188P25
 OpenAir™ Electronic Damper Actuators
 GDE/GLB Series Non-spring Return Rotary
 24 Vac Three-Position Control

Information in this publication is based on current specifications. The company reserves the right to make changes in specifications and models as design improvements are introduced. OpenAir is a trademark of Siemens Building Technologies, Inc. Other product or company names mentioned herein may be the trademarks of their respective owners. © 2003 Siemens Building Technologies, Inc.