



WhisperGreen™

VENTILATION FAN

**FV-08VKML1, FV-08VKSL1, FV-08VKM1,
FV-08VKS1, FV-08VKL1, FV-08VK1, FV-05VK1**

A revolutionary series of vent fans that combine energy efficiency, quietness and a peerless collection of advanced technologies that deliver unparalleled performance.

- CustomVent™ variable speed control with high/low delay timer (Variable 2-Speed with controls only)
- SmartFlow™ system for constant CFM output
- Super energy efficient DC motor
- Ultra-quiet operation
- ENERGY STAR® qualified



FV-08VK1

FV-08VKML1



Panasonic ideas for life



ENERGY STAR® is a U.S. registered trademark.



An outstanding level

Panasonic reaches new heights in distinction among the industry's ventilation fans by improving our already outstanding WhisperGreen™ series. There was a need for light, so we've equipped our variable 2-speed models with it. All models feature remarkably quiet operation, along with the ease of installation that you've been able to count on from Panasonic. And most notable, the WhisperGreen™ line of ventilation fans exceeds ENERGY STAR® standards, and we think it will exceed yours, too!

DC Motor for Lower Energy Consumption

Panasonic WhisperGreen™ Ventilation Fans are an unbelievable 300% - 500% more energy efficient than the minimum ENERGY STAR® requirements. This remarkable performance is thanks to new advanced technologies, including our revolutionary DC motor.

SmartFlow™ Optimum CFM Technology

With SmartFlow™ technology, the fan is designed to perform at a constant CFM, which was nearly impossible until now because of duct length, elbows and other factors that hindered its ability to perform at rated levels. When a WhisperGreen fan faces static pressure, its speed is automatically increased to ensure that the desired CFM is not compromised. This allows the fan to perform as rated and more importantly makes for easier installation because the installer no longer has to worry about compromising the fan's performance.

CustomVent™ Variable Speed Control

This new technology allows the fan to run continuously at a pre-set lower level (30 - 70 CFM). The fan then elevates to a maximum level of operation (80 CFMs) when the switch is turned on, or the SmartAction® motion sensor is activated. A High/Low Delay Timer

returns the fan to the pre-set CFM level after a period of time set by the user, making this the ideal solution for continuous whole house ventilation. (Variable 2-speed with controls only)



SmartAction® Motion Sensor

Featured on the WhisperGreen FV-08VKM1 and FV-08VKML1 models, the SmartAction® sensor automatically activates whenever someone enters or leaves the room.

6-Year Warranty

Panasonic provides a 6-year warranty for the DC motor in its WhisperGreen line.

of energy-efficiency

New Open Hub Structure

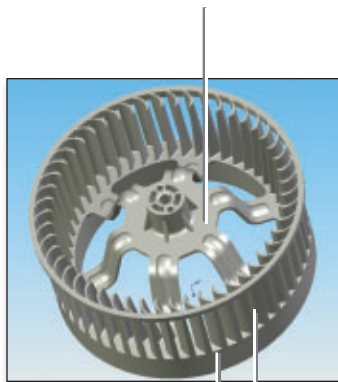

Double-Tapered, Sirocco Fan

Dual Chamber Technology

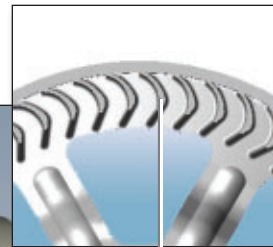
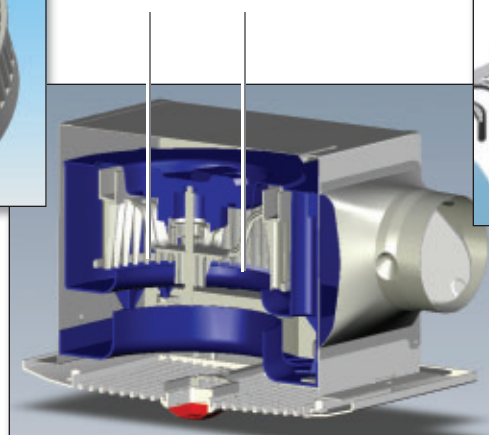

Dolphin-Shaped Blade (Close-up)

ASHRAE 62.2 2007 Standard

The American Society of Heating, Refrigerating and Air Conditioning Engineers (ASHRAE) set a standard for whole house ventilation, requiring that continuous mechanical ventilation be 7.5 CFM per bedroom (master bedroom X 2) plus 1 CFM per 100 square feet, with some level not to exceed 1.0. Panasonic WhisperGreen™ fans are the least expensive, most energy efficient, and quietest way to meet ASHRAE 62.2. ASHRAE has been adopted by LEED for Homes, the ENERGY STAR® Homes Indoor Air Package, and the United States Green Buildings Council (USGBC) for ventilation requirements. Panasonic created WhisperGreen fans specifically to meet 62.2.

Required Continuous Ventilation Rate (CFM)					
Floor area	0-1 BR	2-3 BR	4-5 BR	6-7 BR	>7 BR
<1500	30	45	60	75	90
1501-3000	45	60	75	90	105
3001-4500	60	75	90	105	120
4501-6000	75	90	105	120	135
6001-7500	90	105	120	135	150
>7500	105	120	135	150	165

Sizing example (based on ASHRAE 62.2):

THREE BEDROOMS at 2500 SQ. FT.	
Master Bedroom (7.5 CFM X 2)	= 15 CFM
Other 2 Bedrooms (7.5 CFM each)	= 15 CFM
2500 sq. ft. X .01	= 25 CFM
Total	55 CFM

Use WhisperGreen FV-08VKML1 fans at 30 CFM and 1 WhisperGreen FV-05VK1 fan for 2.5 bathrooms.

Additional Benefits

- ENERGY STAR® qualified
- Totally enclosed motor for long life —rated for continuous run
- Easy installation (double hanger bar system)
- Rust-proof paint treatment on galvanized housing
- Built-in damper to prevent backdraft
- Contemporary grille design
- UL listed for tub/shower enclosure when used with a GFCI branch circuit wire
- Thermal Fuse Protection
- Meets Washington State Ventilation and Indoor Air Quality Code



ENERGY STAR® is a U.S. registered trademark.

Panasonic ideas for life

Variable 2-Speed with Controls



Ceiling-mounted Ventilation Fan
with **SmartAction®** Motion Sensor
FV-08VKML1 **Variable Output** 4" Duct



Ceiling-mounted Ventilation Fan
with **SmartAction®** Motion Sensor
FV-08VKM1 **Variable Output** 4" Duct



Ceiling-mounted Ventilation Fan
FV-08VKSL1 **Variable Output** 4" Duct



Ceiling-mounted Ventilation Fan
FV-08VKS1 **Variable Output** 4" Duct

of energy-efficiency

Single Speed



Ceiling-mounted Ventilation Fan
FV-08VKL1 4" Duct



Ceiling-mounted Ventilation Fan
FV-05VK1 4" Duct / FV-08VK1 4" Duct



WhisperGreen-Lite includes:

- Two 18-Watt Panasonic flicker free compact fluorescent lamps.
Equivalent to 100-Watt incandescent lighting / ENERGY STAR® Qualified /
Electronic ballast / 3500 Kelvin / 1200 Lumens each / 10,000 hours rated life
- 4-Watt night-light
- California Title 24 Compliant

WhisperGreen™ Variable 2-Speed with controls			FV-08VKS1 / FV-08VKM1										FV-08VKS1 / FV-08VKML1												
Characteristics (HVI Certified Data for 0.1" S.P.)	Statistic pressure in inches w. g.	0.1	0.25	0.1	0.25	0.1	0.25	0.1	0.25	0.1	0.25	0.1	0.25	0.1	0.25	0.1	0.25	0.1	0.25	0.1	0.25	0.1	0.25	0.1	0.25
	Air Volume (CFM)	80	74	70	68	60	59	50	49	40	40	30	28	80	78	70	70	60	61	50	50	40	38	30	27
	Noise (sones)	0.3	N/A	<0.3	N/A	<0.3	N/A	<0.3	N/A	<0.3	N/A	<0.3	N/A	0.3	N/A	<0.3	N/A	<0.3	N/A	<0.3	N/A	<0.3	N/A	<0.3	N/A
	Power Consumption (Watts)	11.3	17.3	8.9	15.5	7.6	13.2	6.6	11.2	5.2	9.3	4.7	7.8	13.7	18.7	10.4	16.5	8.5	14.1	7.5	12.5	7.4	10.0	5.3	9.0
	Energy Efficiency (CFMs/Watt)	7.1	4.3	7.9	4.4	7.9	4.5	7.6	4.4	7.7	4.3	6.4	3.6	5.8	4.2	6.7	4.2	7.1	4.3	6.7	4.0	6.3	3.8	5.7	3.0
	Speed	723	957	698	955	685	924	665	913	632	897	615	882	780	975	730	952	692	938	673	923	646	902	631	893
	Current	0.08	0.13	0.07	0.12	0.06	0.10	0.05	0.09	0.04	0.07	0.03	0.06	0.09	0.13	0.07	0.12	0.06	0.10	0.05	0.09	0.04	0.07	0.04	0.06
	Power Rating (V/Hz)	120/60	120/60	120/60	120/60	120/60	120/60	120/60	120/60	120/60	120/60	120/60	120/60	120/60	120/60	120/60	120/60	120/60	120/60	120/60	120/60	120/60	120/60	120/60	120/60
	ENERGY STAR Qualified	Yes												Yes											
Advanced Features	SmartAction® Motion Sensor	N/A (FV-08VKS1) - Yes (FV-08VKM1)												N/A (FV-08VKS1) - Yes (FV-08VKML1)											
	High/Low Delay Timer	Yes												Yes											
	CustomVent Variable Speed Control	Yes												Yes											
	SmartFlow Optimum CFM Technology	Yes												Yes											
Light Specifications	Lamp Watts	N/A												2 x 18											
	Color Rendering Index	N/A												84											
	Color Temperature (Kelvin)	N/A												3,500											
	Rated Life (hours)	N/A												10,000											
	Lamp Model #	N/A												FDS18E35/4											
Night Light Specs	Night Light Watts	N/A												4											
Approved Code/ Standard/ Regulation	UL Tub/Shower Enclosure	Yes												Yes											
	Washington State VIAQ Code	Yes												Yes											
	California Title 24 Compliant	Yes												Yes											
	Mfg in ISO 9001 Certified Facility	Yes												Yes											

WhisperGreen™ Single Speed		FV-05VK1		FV-08VK1		FV-08VKL1	
Characteristics (HVI Certified Data for 0.1" S.P.)	Statistic pressure in inches w. g.	0.1	0.25	0.1	0.25	0.1	0.25
	Air Volume (CFM)	50	49	80	82	80	78
	Noise (sones)	<0.3	N/A	0.3	N/A	<0.3	N/A
	Power Consumption (Watts)	5.9	11.2	11.1	21.5	11.3	20.5
	Energy Efficiency (CFMs/Watt)	8.5	4.4	7.2	3.8	7.1	3.8
	Speed	659	916	733	987	747	973
	Current	0.05	0.09	0.09	0.17	0.04	0.12
	Power Rating (V/Hz)	120/60		120/60		120/60	
ENERGY STAR Qualified	Yes		Yes		Yes		
Advanced Features	SmartAction® Motion Sensor	N/A		N/A		N/A	
	High/Low Delay Timer	N/A		N/A		N/A	
	CustomVent Variable Speed Control	N/A		N/A		N/A	
	SmartFlow Optimum CFM Technology	Yes		Yes		Yes	
Light Specifications	Lamp Watts	N/A		N/A		2x18	
	Color Rendering Index	N/A		N/A		84	
	Color Temp (kelvin)	N/A		N/A		3500	
	Rated Life (hrs)	N/A		N/A		10,000	
	Lamp Model #	N/A		N/A		FDS18E35/4	
Night-Light Specs	Night Light Watts	N/A		N/A		4	
Approved Code/ Standard/ Regulation	UL Tub/Shower Enclosure	Yes		Yes		Yes	
	Washington State VIAQ Code	Yes		Yes		Yes	
	California Title 24 Compliant	Yes		Yes		Yes	
	Mfg in ISO 9001 Certified Facility	Yes		Yes		Yes	

FDS18E35/4 contains mercury. Dispose according to local, state and federal laws.

Panasonic ideas for life

Panasonic Home & Environment Company Unit of Panasonic Corporation of North America

Headquarters

Panasonic Home & Environment Company
One Panasonic Way
Secaucus, NJ 07094

Customer Service

Panasonic Home & Environment Company
5201 Tollview Road
Rolling Meadows, IL 60008

For Order Information:

PHONE: 866-292-7299; FAX: 888-553-0723

For Customer Call Center:

PHONE: 866-292-7292

www.panasonic.com/building

Design and specifications subject to change without notice.



Printed with soy ink on
10% post-consumer
recycled paper.

VF080178SS