



# UV-AIRE AIR PURIFYING SYSTEM

*Model: UV-16R/24*



## ITEMS INCLUDED IN KIT:

- 1- 24Volt UV-Aire Ballast Assembly
- 1-Mounting Base
- 1-Ultraviolet Lamp
- 6-Sheet Metal Mounting Screws
- 1-Instruction Sheet
- 1-Fiberglass Duct Board Mounting Bracket
- 1-UVC Light Shield
- 2-Wire Nuts
- 2-1/4" Male Quick Connect Terminals
- 2-Scotchlok Wire Taps

The UV-Aire unit is designed to emit powerful UVC Band light rays, which sterilize and reduce airborne microorganisms as they pass through a heating or air conditioning system. It is installed in the main supply or return duct and operates continuously to automatically purify the air in the home 24 hours a day.

**This product is not sold as a medical device and is not for the purpose of diagnosis of any disease or condition, nor for use in the mitigation, treatment, or prevention of any disease or condition.**

## READ THESE INSTRUCTIONS CAREFULLY AND COMPLETELY BEFORE PROCEEDING WITH THE INSTALLATION.



**WARNING:** For use with 24V ONLY! Do not exceed voltage rating. Severe damage to device and/or fire could result. Verify proper voltage.

**NOTE:** *This unit may require a supplemental 24V/40VA Transformer.*

**This device MUST be installed by a qualified agency\* in accordance with the manufacturer's installation instructions.** The definition of a qualified agency is: *any individual, firm, corporation or company which either in person or through a representative is engaged in, and is responsible for, the installation and operation of HVAC appliances, who is experienced in such work, familiar with all the precautions required, and has complied with all the requirements of the authority having jurisdiction.*



**FIELD CONTROLS**  
THE VENTING SOLUTIONS COMPANY

**SAFETY CONSIDERATIONS**



**WARNING:** *Never expose eyes or skin to UVC light from any source.*

- Looking directly at the UVC light may cause permanent eye damage or blindness.
- **Never operate the UV-Aire Air Purifying System out of the plenum.**
- Designed for a closed duct system. Do not mount near a supply or a return air opening.
- All duct openings in direct line of site of the UV light must be sealed with aluminum tape or equivalent sealing methods.



**WARNING:** *UV light will break down plastic materials not rated for UV exposure: (Examples: wire insulation, flex duct, drain pans and humidifiers)*

- The unit must be mounted at least 30" from the above stated type of materials.
- If it is necessary to mount the unit in direct line of site of these types of materials, they must be shielded with aluminum foil, aluminum foil tape, or sheet metal.



**WARNING:** *DO NOT mount this unit outdoors.*

- This product is designed for indoor installation only (i.e. Attics, crawl spaces, basements, etc.).



**WARNING:** *Never touch broken lamp or internal contents of lamp. The lamp contains mercury.*

- After opening the carton, unpack and inspect the unit and lamp for damage. Do not install this unit if any damage is noticeable. If lamp is damaged, cracked or broken, do not touch lamp or other contents in carton. Close carton and return to seller immediately.
- In case of accidental exposure to internal contents of lamp, wash hands and any other affected skin area with mild detergent. Remove affected clothing immediately. If skin surface is pierced, seek medical attention immediately.

**NOTE:** *If you touch the glass of the lamp, you should wipe the glass clean with isopropyl alcohol and a lint free wipe. If the lamp is not cleaned, the film of hand oils causes a reduction in the light intensity.*



**WARNING:** *Before installing or servicing a humidifier, air filter, HVAC system, or this unit, etc., always turn all power OFF and have unit unplugged. Electrical shock can cause personal injury or death. Never expose eyes or skin to direct UVC light from any source.*



**WARNING:** *To prevent water damage or electric shock, do not mount unit under a humidifier.*



**WARNING:** *This product is designed for indoor installation only (i.e. attics, crawl spaces, basements, etc.). For use on gas fired, oil fired, electric and split system heat pump forced air systems\*. This product is NOT designed to be mounted outside on gas fired or heat pump packaged units\*\*.*

*\*Split system heat pumps are systems where the air handler and the air conditioning compressor are separate units.*

*\*\*Packaged units are systems where the air handler and the air conditioning compressor are built together and are installed outside of the building.*

**GENERAL INFORMATION**

The UV-Aire unit uses technology that is recommended by doctors who state that “ultraviolet radiation, properly integrated with heating, ventilating, and air conditioning systems, shows the most promise as a widely applicable means of air disinfection”.<sup>1</sup>

**Optional UVC-Light Shield:**

Designed to mount at virtually any angle to guard or shield certain plastics, wiring or air filters that may be affected by UVC light.

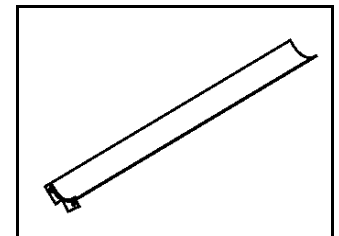

*Optional UVC-Light Shield*

**SIZING AND SELECTING UNITS**

See chart below:

Square Footage	UV-Aire (For ducts at least 16" wide)	Volts	Watts	Amps	Hz
Up to 2000	1	24	23	1.3	60
4000	2	24	46	2.6	60

Notes:

- For applications with multiple systems, we recommend one unit per system.
- For larger applications, multiple units are recommended. Contact technical support at 1-252-522-3031 for sizing.
- Each unit will require it's own transformer.



**WARNING:** *Never expose eyes or skin to UVC light from any source. Looking directly at the UVC light may cause permanent eye damage or blindness. Never operate the UV-Aire Air Purifying System out of the plenum. Avoid touching the glass portion of the lamp with your hands.*

## INSTALLATION

1. Locate a suitable location for the unit downstream from the 'A' coil in the supply plenum or in the return plenum; preferably downstream from the air filter. For optimum "cleaning" effect on the 'A' coil, mount the unit in the supply plenum as close as possible to the 'A' coil. (See Figure 1)

**CAUTION:** Investigate and determine the location of the A coil prior to drilling holes in duct for mounting unit.

**NOTE:** For duct board installation, refer to enclosed bagged assembly containing mounting plate and instructions.

2. Apply supplied mounting template to air duct in either a vertical or horizontal position as shown in Figure 2. (Leave template mounted to duct for future reference.)
3. Drill 1/8" diameter mounting holes at positions indicated on template. (Refer to supplied template as shown in Figure 3)
4. Cut out the large opening (1-1/2" hole) on the template. (Refer to template as shown in Figure 3)
5. Using a 1/4" to 1/2" drill bit, drill a viewport hole as indicated on the template. (Figure 3)
6. Optional Light Shield: The light shield may be mounted at virtually any angle. However, when deciding on a suitable location, the mounting screw head can not be in the shaded area of template. (See Figure 4 to view areas to avoid.)
7. Press shield onto duct wall then secure with screws. (See Figure 5)

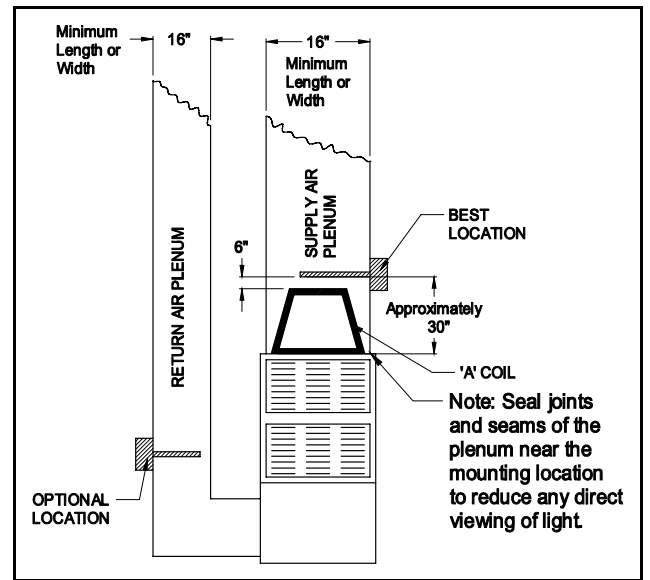

Figure 1

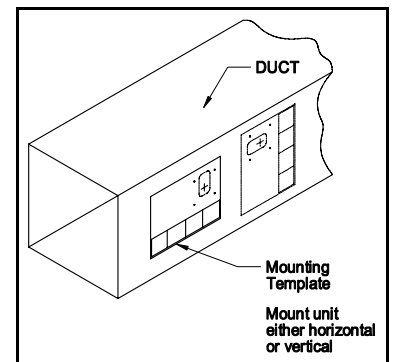

Figure 2

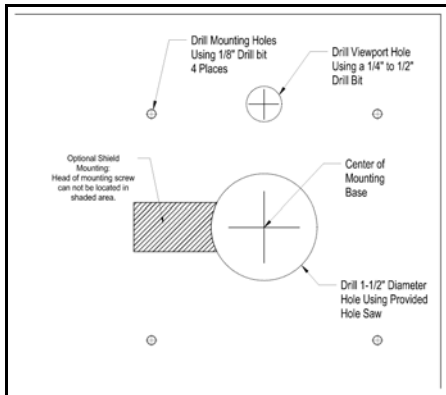

Figure 3

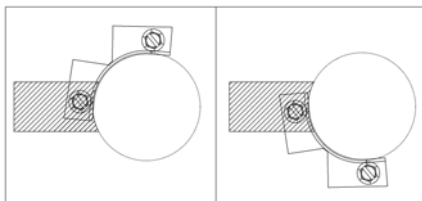

Figure 4  
Head of mounting screw **CAN NOT** be located in shaded area

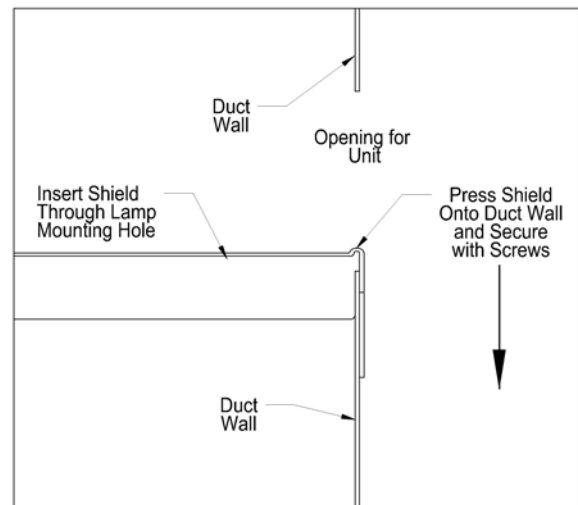

Figure 5

**WARNING:** Never expose eyes or skin to UVC light from any source. Looking directly at the UVC light may cause permanent eye damage or blindness. **Never operate the UV-Aire Air Purifying System out of the plenum.** Avoid touching the glass portion of the lamp with your hands.

- Attach the UV-Aire mounting base onto the plenum with the supplied sheet metal screws. (Refer to template as shown in Figure 3) **This must be tight in order to activate the built in safety switch.**

**NOTE:** DO NOT remove template from duct.

- Do not handle the lamp with bare hands. Oils on your hands tend to reduce lamp intensity. Install lamp into ballast. (See Figure 6)
- Wipe off the lamp glass with the supplied alcohol wipe. Then insert the lamp through the center hole of the mounting base. (See Figure 7) The power cord must be 90° to the viewport hole on the mounting base.
- With the ballast pressed against the mounting base, rotate the ballast clockwise 90°.
- Do not wire the unit into the appliances 24 volt fan or thermostat circuit. Premature failure of the ballast and lamp will occur. The warranty will be void. Do not wire into a standard 120VAC electric supply. Wire according to Diagram A or Diagram B. Unit is designed to be wired to a 24V/40VA power supply only. Check lamp operation by looking through the viewport hole.

**NOTE:** The viewport hole is made of glass and will not allow any UVC rays to pass through. A blue glow should be seen in the duct.

- If blue glow is not seen, make sure the base is properly installed onto duct. There is a proving switch located on the base that needs to be seated properly onto the duct. **Make sure when installing the base the plated washer on the switch is raised approximately 3/16". The proving switch must be fully engaged.** (See Figure 8)
- With aluminum or foil tape, seal all joints and seams of the plenum near the mounting location to reduce any direct viewing of light.

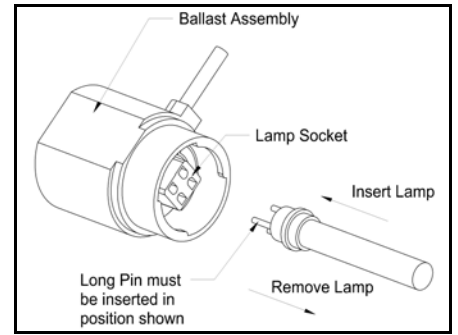

Figure 6

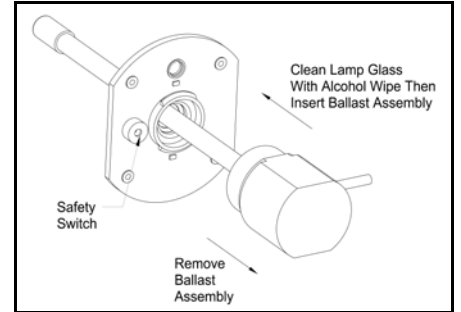

Figure 7

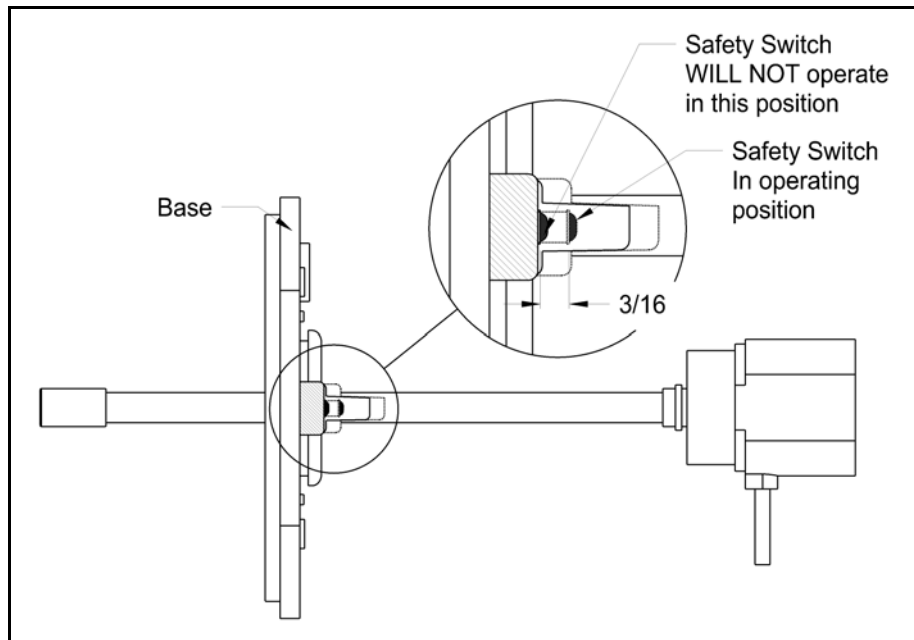

Figure 8



**WARNING:** Never expose eyes or skin to UVC light from any source. Looking directly at the UVC light may cause permanent eye damage or blindness. **Never operate the UV-Aire Air Purifying System out of the plenum.** Avoid touching the glass portion of the lamp with your hands.

## MAINTENANCE



**WARNING:** Disconnect power to the transformer before commencing inspection and cleaning.

**NOTE:** Wear disposable, non-absorbent protective gloves prior to inspection procedure in case of accidental breakage of glass.

1. We recommend inspecting and cleaning the lamp at least every 6 months. Frequency depends upon the environment. Such as: the type of air filter, duration of use and replacement cycle.
2. To maintain maximum output intensity, replace the UV-Aire lamp annually. The lamp should operate continuously for maximum lamp life and light effectiveness.

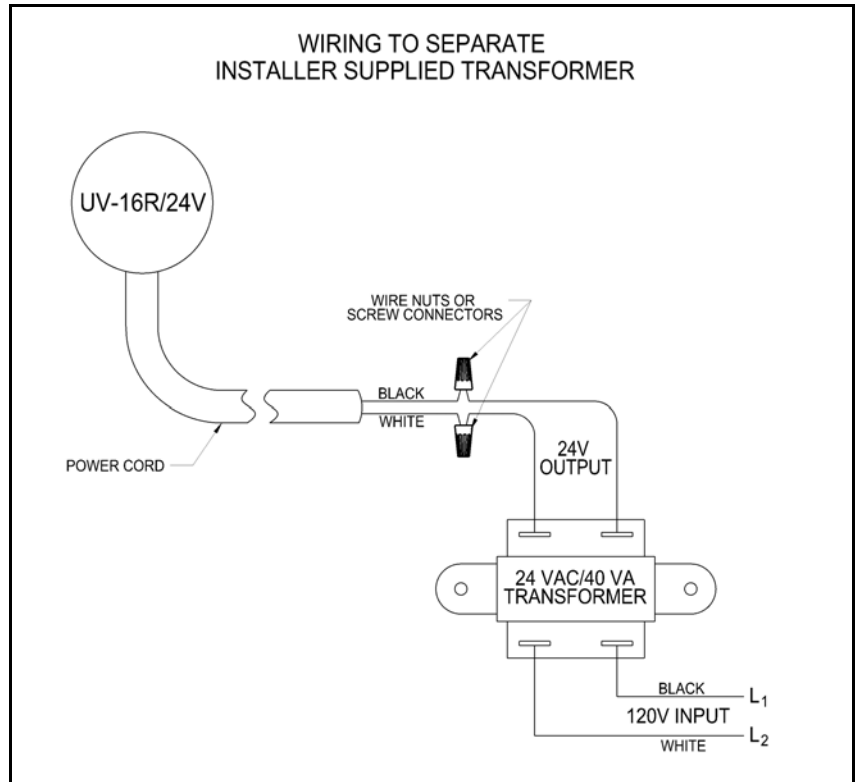

Diagram A

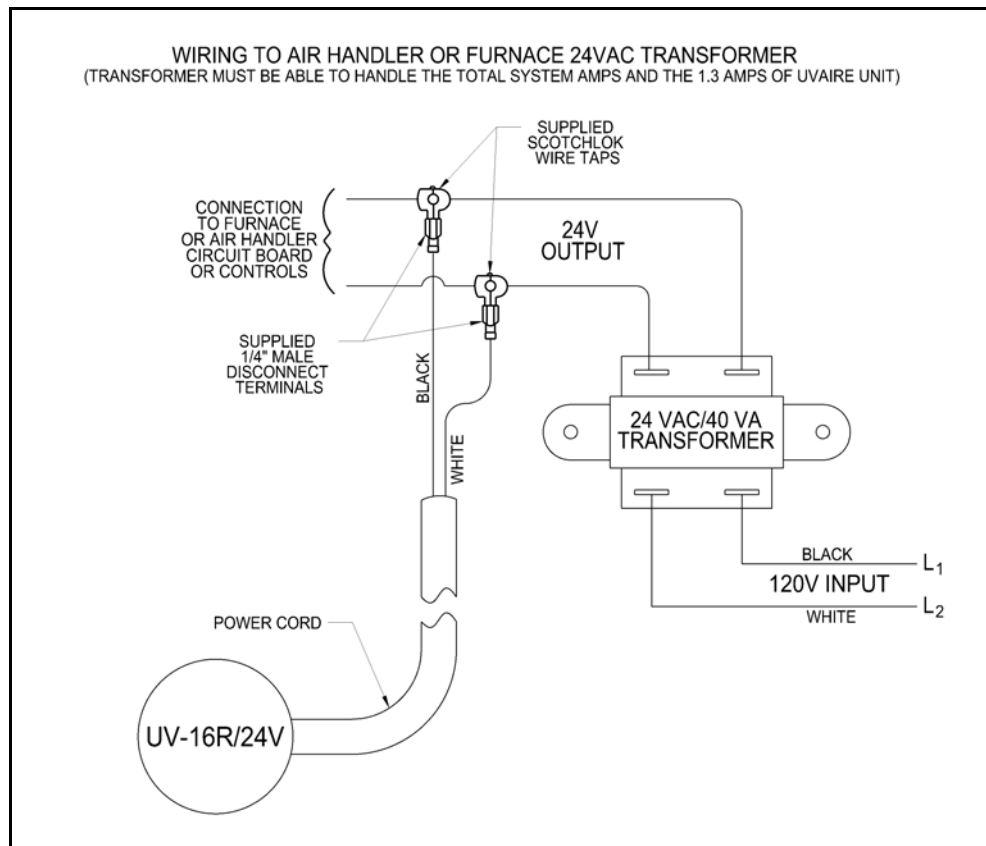

Diagram B



**WARNING:** Never expose eyes or skin to UVC light from any source. Looking directly at the UVC light may cause permanent eye damage or blindness. **Never operate the UV-Aire Air Purifying System out of the plenum.** Avoid touching the glass portion of the lamp with your hands.

## REPLACEMENT PROCEDURE



**WARNING:** Disconnect power to the transformer before starting replacement procedure.

**NOTE:** Wear disposable, non-absorbent protective gloves prior to replacement procedure in case of accidental breakage of glass.

1. Rotate the UV-Aire ballast assembly counter-clockwise until it stops. (See Figure 9)
2. Remove the ballast assembly and lamp from the mounting base. (See Figure 7)
3. Remove the lamp from the lamp socket. (See Figure 6)
4. Install the replacement lamp into lamp socket. Do not handle the lamp with bare hands. Oils on the hands tend to reduce lamp intensity.
5. Wipe off the glass with the supplied alcohol wipe.
6. Position the ballast assembly power cord 90° to the viewport hole on the mounting base. (See Figure 9)
7. Slide the lamp through the hole in the mounting base. (See Figure 7)
8. Press the ballast against the mounting base. Rotate the ballast assembly clockwise until it stops and is locked in place. (See Figure 10)
9. After assembly is firmly in place, reconnect power to transformer, and plug the power supply cord back into the standard electrical outlet. Check lamp operation by looking through the viewport hole. A blue glow should be seen in the duct.
10. After replacing the lamp, make sure to install the *Lamp Replacement Label*. Print the date on the label and apply to the side of ballast assembly.

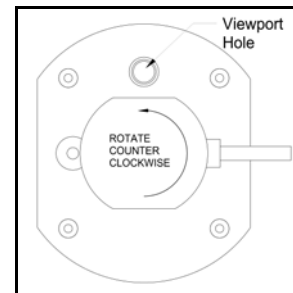

Figure 9

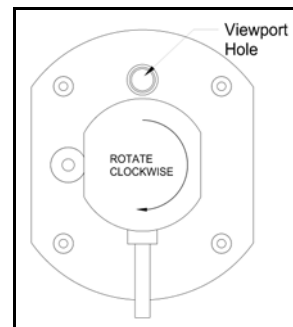

Figure 10

**NOTE:** If blue light leaks through any portion of plenum and/or around mounting plate, unplug power supply cord immediately and seal affected areas and/or rotate ballast and repeat step #8.

11. UV lamps contain a small amount of mercury, like a typical fluorescent lamp. Check with your local waste management authority for local disposal or recycling requirements. According to the EPA's Universal Waste Rule, these types of lamps may be disposed of into household waste.



**WARNING:** Never touch broken lamp or internal contents of lamp. The lamp contains mercury.

**NOTE:** In case of accidental exposure to internal contents of lamp, wash hands and any other affected skin area with mild detergent. Remove affected clothing immediately. If skin surface is pierced, seek medical attention immediately.

## TROUBLESHOOTING GUIDE

1. Do not wire the unit into the appliance 24 volt fan or thermostat circuit. This will cause premature ballast or lamp failure and void the warranty. For proper operation, the unit requires 24VAC at all times.
2. Check to make sure 24VAC power is available at the transformer.
3. If lamp does not light up, pull back metal washer on mounting base. If lamp comes on, the base needs tightening to ensure that the safety switch is fully engaged
4. If lamp does not light up, rotate ballast slightly clockwise or counter-clockwise
5. If lamp does not light up after rotating ballast, replace lamp.
6. If unit still does not light up after replacing lamp, replace unit.

## REPLACEMENT PARTS LIST

LAMP Replacement Part Number
46511200

For replacement parts, contact Field Controls at:

☎ Phone: 1-252-522-3031 • 📠 Fax: 1-252-522-0214

✉ Email: [sales@fieldcontrols.com](mailto:sales@fieldcontrols.com)



**WARNING:** Never expose eyes or skin to UVC light from any source. Looking directly at the UVC light may cause permanent eye damage or blindness. **Never operate the UV-Aire Air Purifying System out of the plenum.** Avoid touching the glass portion of the lamp with your hands.

**CLEAN-UP OF BROKEN LAMPS** (see warnings on page two of this manual)

UV lamps contain a small amount of mercury, like a typical fluorescent lamp. DO NOT touch any of the mercury with your bare hands.

1. While wearing disposable, non-absorbent protective gloves. Carefully pick up the large pieces of glass with your hands.
2. Vacuum the entire area with a standard household vacuum cleaner ensuring the removal of all lamp material.
3. Dispose of the pieces of glass, the vacuum cleaner bag, and the disposable gloves in a sealed garbage bag.
4. Check with your local waste management authority for local disposal or recycling requirements. According to the EPA's Universal Waste Rule, these types of lamps may be disposed of into household waste.
5. Wash hands and remove and wash clothes for added safety measures.

*The health aspects associated with the use of these products and their ability to aid in disinfecting of environmental air have not been investigated by UL.*



**WARNING:** Never expose eyes or skin to UVC light from any source. Looking directly at the UVC light may cause permanent eye damage or blindness. **Never operate the UV-Aire Air Purifying System out of the plenum.** Avoid touching the glass portion of the lamp with your hands.

1. Richard Riley, M.D. "Airborne Infection: The American Journal of Medicine, September 1974, Vol. 57 - 5/16/01



**FIELD CONTROLS**  
**The Venting Solutions Company™**

2630 Airport Road, Kinston, NC 28504  
1-252-522-3031 • [www.fieldcontrols.com](http://www.fieldcontrols.com)

P/N 46520200 09/06