

INSTALLER'S & OWNER'S MANUAL

HVAC INSTALLER: PLEASE LEAVE MANUAL FOR HOMEOWNER

Ultra·Aire™ QUIET-VENT



P/N 4019663 • Serial No. _____ Install Date: _____

Sold by:



Therma-Stor[®] LLC

Driven by performance. Powered by design.™

P.O. Box 8680 Madison, WI 53708 • TOLL-FREE 1-800-533-7533 • www.thermastor.com • sales@thermastor.com

TS-174B

TABLE OF CONTENTS

Table of Contents

1. Specifications	1
2. Installation	1
2.1 Back-Drafting Open Combustion Devices.....	1
2.2 Location of the Ultra-Aire Quiet Vent.....	2
2.3 Fresh Air Inlets	3
2.4 Hanging the Ultra-Aire Quiet Vent.....	3
2.5 Ducting to and from the Ultra-Aire Quiet Vent.....	3
2.6 Wiring the Ultra-Aire Quiet Vent.....	3
3. Operation.....	4
3.1 Using the Timers	4
3.2 Adjusting the Amount of Ventilation	4
4. Maintenance	4
4.1 Cleaning the Blower Screen	4
5. Service	4
5.1 Circuit Breaker Trips.....	4
5.2 Blower Operates on One Speed Only.....	5
5.3 7-Day Timer Does Not Advance.....	5
5.4 Fan Motor	5
5.5 Warranty	5
6. Service Parts List	5
7. Warranty.....	6

Read and Save These Instructions

 **WARNING!** — This symbol indicates important instructions. Failure to heed them can result in serious injury or death.

 **CAUTION!** — This symbol indicates important instructions. Failure to heed them can result in injury or material property damage.

1. Specifications

Model:	Ultra-Aire Quiet Vent
Part Number:	4019663
Electrical Specs:	110-120Vac, 60Hz, 1ph
Max HACR Type Circuit Breaker or Fuse:	10A
Blower:	0.65 Amps, Thermally Protected
Capacitor:	370 VAC, 6 MFD

2. Installation

 **WARNING: To reduce the risk of fire, electric shock, or injury to persons, observe the following:**

- A. Installation work and electrical wiring must be done by qualified person(s) in accordance with all applicable codes and standards, including fire-rated construction.
- B. Sufficient air is needed for proper combustion and exhausting of gases through the flue (chimney) of fuel burning equipment to prevent backdrafting. Follow the heating equipment manufacturer's guideline and safety standards such as those published by the National Fire Protection Association (NFPA), and the American Society for Heating, Refrigeration and Air Conditioning Engineers (ASHRAE), and the local code authorities.
- C. When cutting or drilling into wall or ceiling, do not damage electrical wiring and other hidden utilities.
- D. Ducted fans must always be vented to the outdoors.
- E. If this unit is to be installed over a tub or shower, it must be marked as appropriate for the application.
- F. NEVER place a switch where it can be reached from a tub or shower.

2.1 Back-Drafting Open Combustion Devices

 **CAUTION: Do not use open combustion heating appliances (unless equipped with power exhaust) in a home equipped with exhaust fans (i.e., bath fans, kitchen hoods, down draft stoves, or the Ultra-Aire Quiet**

SAFETY PRECAUTIONS

Vent System).

Under certain conditions, these fans may cause the backdrafting of toxic combustion by-products that are hazardous to human health and could cause death. Therefore, we strongly recommend using only closed combustion (direct-vent or aerodynamically decoupled) heating appliances in weather tight homes. Most furnaces, fireplaces and water heaters are now available with sealed combustion or power exhaust.

2.2 Location of the Ultra-Aire Quiet Vent

Ideally each bathroom and the kitchen are ducted with a

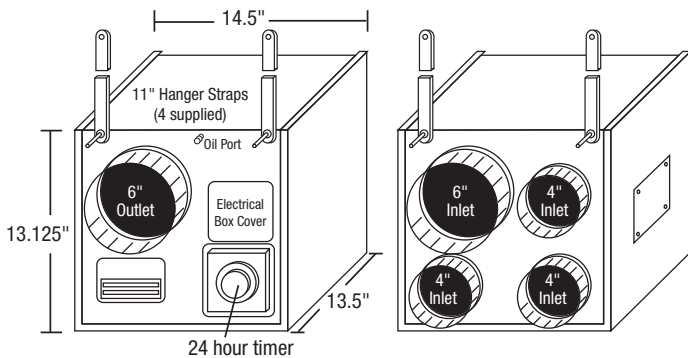

4" duct to the Ultra-Aire Quiet Vent (See Fig. 1). To make installation easy, the Ultra-Aire Quiet Vent has one 6" and three 4" duct inlet Connections. The 6" outlet of the Ultra-Aire

Quiet Vent is ducted to the outside of the home. The Ultra-Aire Quiet Vent should be positioned in the home to minimize the amount of duct and wire required for installation. The unit should be mounted and oriented to allow cleaning of the internal blower screen via the side mounted clean-out port, and adjustment of the 7-day timer (the timer can be remote mounted away from the Ultra-Aire Quiet Vent (see paragraph F). In cold climates the unit should be located in a heated space to prevent condensation from forming inside the cabinet. A basement or utility room is an ideal location.

If the Ultra-Aire Quiet Vent and its ducting must be located in a unheated space in a cold climate, they must be insulated to prevent condensation from forming in the system.

If the Ultra-Aire Quiet Vent is used to correct a moisture problem in an existing house, a 6" duct should be run from near the ceiling in the center of the house to the Ultra-Aire Quiet Vent (see Fig. 1). This will provide adequate ventilation.

2.3 Fresh Air Inlets

The "FRESH 80" fresh air inlets are recommended to provide fresh air to the bedrooms and prevent excessive depressurization. These fresh air inlets should be located on an exterior wall near the ceiling in any isolated rooms that are occupied for extended periods of time with the door closed. These vents have an adjustable opening, a filter and a shut off valve. One air inlet is recommended in each

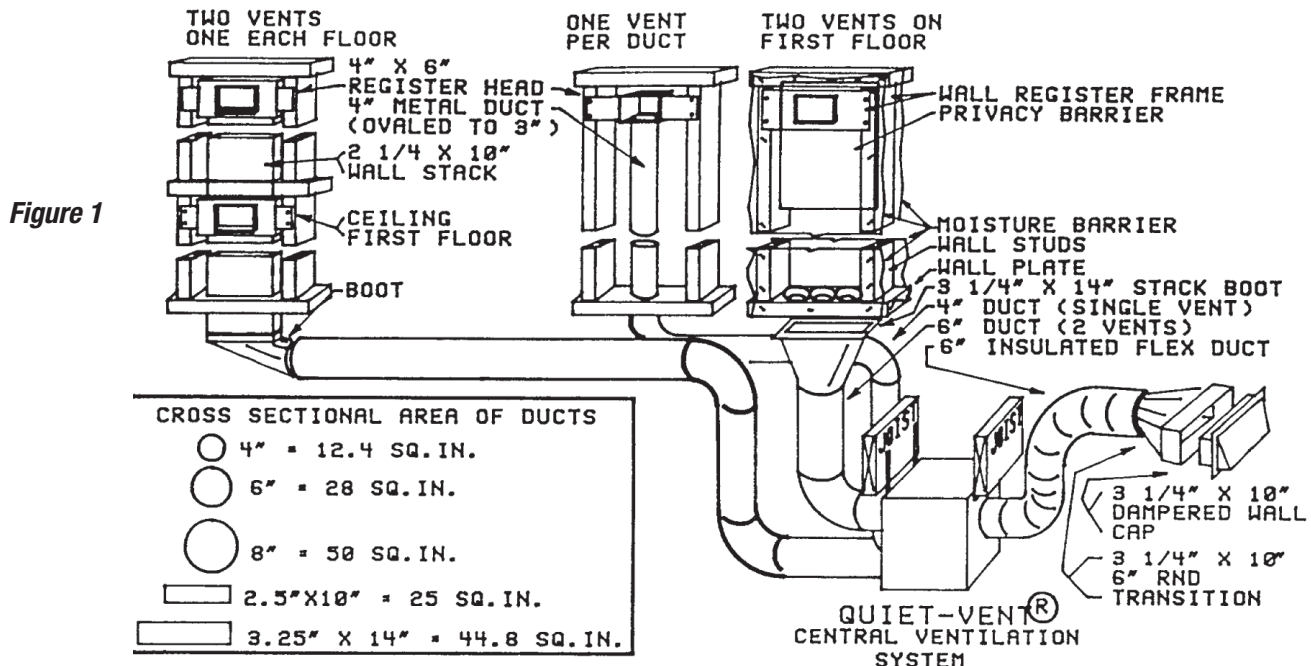

NOTE: 1. FLEXIBLE DUCT IS AN ACCEPTABLE ALTERNATIVE TO METAL DUCT.
 2. SHORT DUCT RUNS OR A POWDER ROOM REQUIRE A BLADE DUCT DAMPER TO AVOID POSSIBLE OVER VENTILATION.

FOR HVAC INSTALLER ONLY

bedroom.

2.4 Hanging the Ultra-Aire Quiet Vent

The Ultra-Aire Quiet Vent has four vibration absorbing straps for hanging from joists, rafters, or trusses and use (4) 1/4" diameter lag bolts or the equivalent. Locate the unit to minimize the ducting from the baths and kitchen to the Ultra-Aire Quiet Vent inlets and from the Ultra-Aire Quiet Vent outlet to the outside.

2.5 Ducting to and from the Ultra-Aire Quiet Vent

All flexible ducting connected to the unit should be UL listed. The preferred method of ducting the exhaust air from the rooms is to use 4" round duct from 4" x 6" register heads located in the wall cavities or the ceiling. For routing through 3.5" stud cavities, flatten the 4" round duct to 3.25". If a 4" duct length from a full bath or kitchen exceeds 50', two 4" ducts or a 6" duct is recommended. The 4" duct can be either metal or flexible and can be routed to the Ultra-Aire Quiet Vent 4" inlet or manifolded to a 6" duct. If more than four 4" ducts are connected to the Ultra-Aire Quiet Vent, use a 6" manifold on the Ultra-Aire Quiet Vent's 6" inlet.

DO NOT locate the register head connecting the kitchen duct to the Ultra-Aire Quiet Vent in the area designated in Fig. 2.

To exhaust the stale air, connect a six inch insulated flexible duct from the outlet of the Ultra-Aire Quiet Vent to a dampered six inch wall cap. If the length of the exhaust duct

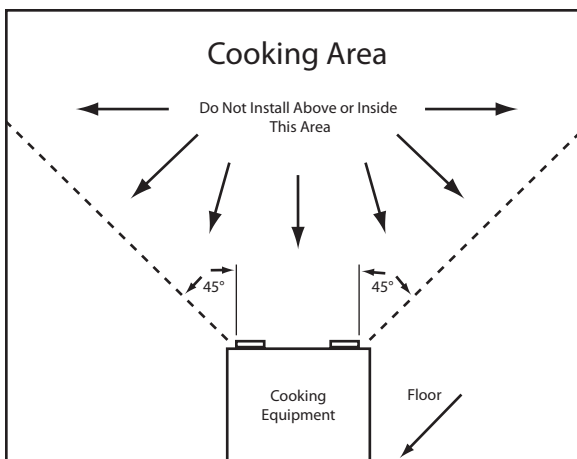
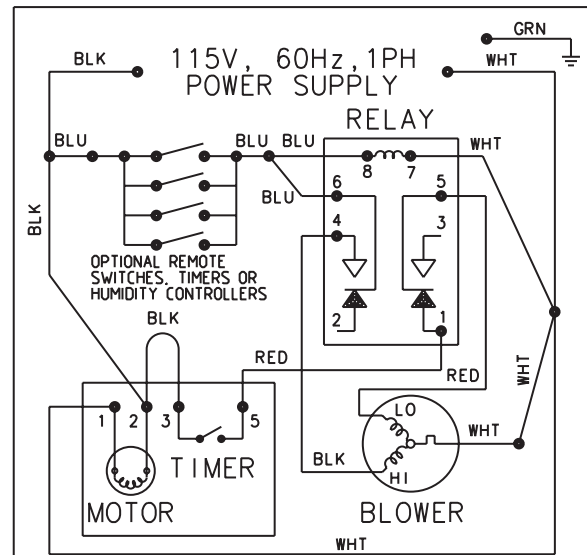
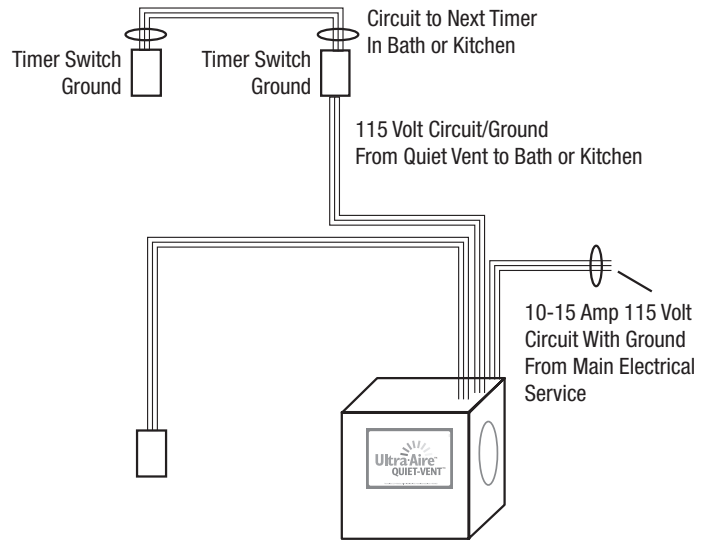

Figure 2

exceeds 50 ft., an 8" duct should be used. All the ducts must be insulated when they are located in non-heated space in a cold climate. Flexible duct can be spliced by threading the ends of the ducts into each other 3 turns. To reduce leakage, all the duct couplings should be taped with 3 turns of duct



MODEL PART NO. 4019663		
LABEL PART NO. 4019654		REV. B

Made in USA
Therma-Star LLC, Madison, Wisconsin
800-533-7533 or Local 608-222-5301
www.thermastar.com

Figure 3

tape. Several ducting alternatives are illustrated in Fig. 1.

2.6 Wiring the Ultra-Aire Quiet Vent

NOTE: All electrical connections must be installed by a qualified electrician. All wiring must conform to the local electric codes and/or the National Electrical Code.

Ultra-Aire Quiet Vent uses a 115 volt, 10 amp circuit which is connected to the black and white wires in the electrical cabinet (see Fig. 3). Spring wound one hour remote timers or humidity controllers located in the baths and kitchen are wired in parallel to the two blue wires. These remote controls

FOR HVAC INSTALLER ONLY

activate the high speed of the exhaust fan. These controls are to be UL listed with minimum electrical ratings of 2 amps inductive load at 125 VAC.

The prewired 7 day timer located on the Ultra-Aire Quiet Vent activates the low speed of the exhaust fan. The timer can be mounted remote from the Ultra-Aire Quiet Vent. This requires a double gang electrical box and 3 conductors plus ground to extend connections to the timer from the Ultra-Aire Quiet Vent.

A 4" junction box cover is used to cover the timer opening on the Ultra-Aire Quiet Vent.

⚠ WARNING: To reduce the risk of fire, electric shock, or injury to persons, observe the following:

A. Use this unit only in the manner intended by the manufacturer. If you have questions, contact the manufacturer.

B. Before servicing or cleaning unit, switch power off at service panel and lock service disconnecting means to prevent power from being switched on accidentally. When the service disconnecting means cannot be locked, securely fasten a prominent warning device, such as a tag, to the service panel.

⚠ CAUTION: For general ventilating use only. Do not use to exhaust hazardous or explosive materials and vapors.

3. Operation

3.1 Using the Timers

1. Setting The 7-Day Timer

Rotate the timer dial until the white pointer indicates the correct time of day. Each segment moved toward the dial center represents 2 hours of low speed exhaust fan operation. Typically, the timer is set to operate during the time of occupancy. If additional ventilation is required to control moisture and odors, additional spades can be moved in. If the home becomes too dry, decrease the hours of low speed operation.

3.2. Using Remote Timers

Estimate the ventilation time required and set it on the timer.

Activate the timer whenever moisture or odors are generated in the room. If timers are not available locally, they may be ordered with the Ultra-Aire Quiet Vent.

3.2 Adjusting the Amount of Ventilation

The amount of air removed from the home depends on the restrictions in the duct system and the amount of time the system operates. If more or less ventilation is required the 7-day timer can be set for more or less low speed operation. The air flow can be reduced by installing a duct damper in the exhaust duct of the Ultra-Aire Quiet Vent.

By partially closing the damper, the CFM of stale air removed from the house can be reduced. Figure 4 indicates air flow and power consumption versus static duct pressure.

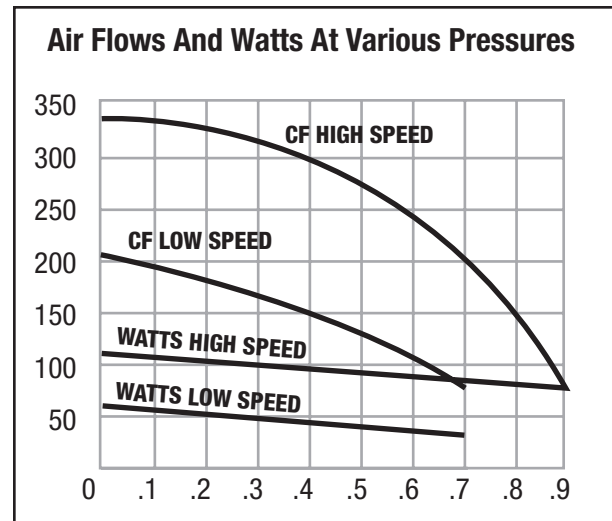

Figure 4

4. Maintenance

4.1 Cleaning the Blower Screen

WARNING: Disconnect the appliance from the power supply before cleaning the blower screen.

A coarse screen covers the blower inlet port located inside the Ultra-Aire Quiet Vent cabinet. Vacuuming the screen is recommended every six months. Remove the 4" x 4" cover on the side of the Ultra-Aire Quiet Vent cabinet for access (See Fig. 1).

5 Service

⚠ CAUTION: Requires a qualified service person because electrical shock hazard is present.

5.1 Circuit Breaker Trips

Check For Short In Wiring:

FOR HVAC INSTALLER ONLY

Turn off the 7-day timer by moving all the spades out. Turn off all the remote timers and the dehumidistat (if used). If the circuit breaker trips, locate a short in the wiring. If the circuit breaker does not trip, activate the 7-day timer. If the circuit breaker then trips, check the blower motor.

5.2 Blower Operates on One Speed Only

Operates On Low Speed Only:

If the blower operates only on low speed, deactivate the 7-day timer so that unit is not running. Activate one of the optional controls and then check for voltage to the relay coil (terminals 7 and 8). See Figure 3. If voltage is not present, check for a loose wire or a defective optional control. If voltage is present, check for voltage between relay terminal 4 and ground. If there is no voltage, the relay is defective. If there is voltage at terminal 4 and the motor does not operate, the high speed winding of the blower motor is defective. Replace the blower.

Operates On High Speed Only:

High speed operation of the blower has priority over low speed. Verify that all the optional controls are in the off position. If the blower operates on high speed constantly, check for voltage between relay terminals 7 and 8. If voltage is present, one of the optional controls is not opening and is defective.

If the blower operates only on high speed (when the optional controls are activated) and is off the rest of the time, check that the segments on the 7-day timer are moved to the center of the dial, thus calling for low speed ventilation. If the blower does not run with the segments in and the optional controls off, check for voltage between timer terminal 5 and ground. If terminal 5 does not have voltage, the timer is defective. If terminal 5 has voltage and relay terminal 5 does not have voltage, the relay is defective. If relay terminal 5 has voltage, the low speed winding of the blower motor is defective.

5.3 7-Day Timer Does Not Advance

Check for voltage between timer terminals 1 and 2. If voltage is present and the timer does not advance, the timer motor is defective and the timer must be replaced.

5.4 Fan Motor

If the blower motor fails to operate when voltage is present at its leads, the motor is defective and the blower must be replaced.

5.5 Warranty

The Ultra-Aire Quiet Vent is guaranteed for two years from the date of installation against all manufacturing defects provided the Ultra-Aire Quiet Vent has been installed, operated, and maintained as stated in this manual. This warranty is limited to the repair or replacement of the equipment, F.O.B. MADISON, WI. Call the factory at 1-800-533-7533.

6. Service Parts

Item	Part Number	Qty.	Description
1	4026929	1	Blower, w/Capacitor, 115V
2	4019782	4	Mounting Strap, Rubber
3	4019649	1	Relay, DPDT, 120V, 10A
4	4019648	1	Timer, 7-Day (Diehl TA-4073, Model 880)
5	4019641	1	Wire Harness, L1
6	4019642	1	Wire Harness, L2
7	4019643	1	Wire Harness, Blue
8	4019644	1	Wire Assembly, Red
9	4019645	1	Wire Assembly, Green
10	4019654	1	Wiring Diagram



Ultra-Aire™
QUIET-VENT

Limited Warranty

Warrantor:
Therma-Stor LLC
PO Box 8680
Madison, WI 53708
Telephone: 1-800-533-7533

Who Is Covered: This warranty extends only to the original residential end-user of the Ultra-Aire Quiet Vent Ventilating System, and may not be assigned or transferred.

Warranty: Therma-Stor LLC warrants that, for two (2) years from the date of installation, the Ultra-Aire Quiet Vent Ventilating System will operate free from any defects in materials and workmanship, provided the Ultra-Aire Quiet Vent has been installed, operated, and maintained as stated in the installation and operation manual. This warranty is limited to the repair or replacement of the equipment F.O.B. Madison, WI. Call the factory at 1-800-533-7533.

Limitation and Exclusions: If any Ultra-Aire Quiet Vent Ventilating System part is repaired or replaced, the new part shall be warranted for only the remainder of the original warranty period applicable thereto (but all warranty periods will be extended by the period of time, if any, that the Ultra-Aire Quiet Vent is out of service while awaiting covered warranty service).

UPON THE EXPIRATION OF THE WRITTEN WARRANTY APPLICABLE TO THE Ultra-Aire Quiet Vent VENTILATING SYSTEM OR ANY PART THEREOF, ALL OTHER WARRANTIES IMPLIED BY LAW, INCLUDING MERCHANTABILITY AND FITNESS FOR A PARTICULAR PURPOSE, SHALL ALSO EXPIRE. ALL WARRANTIES MADE BY THERMA-STOR LLC ARE SET FORTH HEREIN, AND NO CLAIM MAY BE MADE AGAINST THERMA-STOR LLC BASED ON ANY ORAL WARRANTY. IN NO EVENT SHALL THERMA-STOR LLC, IN CONNECTION WITH THE SALE, INSTALLATION, USE, REPAIR OR REPLACEMENT OF ANY Ultra-Aire Quiet Vent VENTILATING SYSTEM OR PART THEREOF BE LIABLE UNDER ANY LEGAL THEORY FOR ANY SPECIAL, INDIRECT OR CONSEQUENTIAL DAMAGES (THE END-USER SHOULD TAKE PRECAUTIONS AGAINST SAME), OR LOSS OF USE OR DAMAGE TO ANY REAL OR PERSONAL PROPERTY.

Some states do not allow limitations on how long an implied warranty lasts, and some do not allow the exclusion or limitation of incidental or consequential damages, so one or both of these limitation may not apply to you.

Legal Rights: This warranty gives you specific legal rights, and you may also have other rights which vary from state to state.



Therma-Stor[®] LLC

PO Box 8680 • Madison, WI 53708

Phone: 608-222-5301 • Fax: 608-222-1447

Web: www.thermastor.com • Email: sales@thermastor.com

Information in this document is subject to change without notice. No part of this document may be reproduced or transmitted in any form or by any means, electronic or mechanical, for any purpose, without the express written permission of Therma-Stor LLC. © 2008 Therma-Stor LLC. All rights reserved.