

TrueSTEAM™

Honeywell



Homeowner's Operating Manual

Must be installed by a trained, experienced technician

Read these instructions carefully. Failure to follow these instructions can damage the product or cause a hazardous condition.



E S

Table of contents

About your new humidifier

TrueSTEAM controls	1
Maintaining ideal humidity.....	2
TrueSTEAM function and operation	3
Setting the controls.....	4

Maintenance and operation

LED light indicators.....	5
Cleaning and maintenance	6
Seasonal or vacation maintenance.....	8

Troubleshooting and repair

Homeowner troubleshooting	9
Limited warranty.....	10

Need Help?

For assistance with this product please visit <http://yourhome.honeywell.com>
or call Honeywell Customer Care toll-free at **1-800-468-1502**

Read and save these instructions.

About your new humidifier

Congratulations on your new humidifier. Your Honeywell TrueSTEAM direct-injection humidifier provides the high performance and efficiency of steam humidification with easier maintenance than traditional humidifiers.

Benefits

- Actually controls your equipment for maintaining desirable humidity levels in your home year-round.
- Requires less water, reducing usage up to 70% when compared to flow-through humidifiers.

TrueSTEAM comes with one of the following control packages:



VisionPRO IAQ Total Comfort System YTH9421C1002

- Controls both temperature and TrueSTEAM.
- Sensor for displaying outdoor temperature.
- Intuitive user interface for easy 7-day temperature programming.
- Easy-to-read backlit digital display.
- Maintenance and service reminders.
- Controls other air quality equipment when you're ready.



TrueIAQ Digital Control DG115EZIAQ

- Automatic adjustments maintain ideal humidity.
- Sensor for displaying outdoor temperature and humidity.
- Shows actual humidity and desired setting.
- Maintenance and service reminders.
- Controls other air quality equipment when you're ready.



Manual Control H8908ASPST

- Manual control with intuitive comfort settings.
- Integrated humidity chart for accurate control in changing conditions.

Maintaining ideal humidity

Optimal Relative Humidity (RH) is defined by industry experts* as between 40-60% RH on an average annual basis, and 35% during the heating season in dry climates. An environment with too little humidity leaves the body vulnerable to viruses and bacteria, and can cause woodwork in the house to shrink and crack. On the other hand, too much humidity creates ideal conditions for mold and mildew growth.

Proper indoor humidity can also help you save money on energy bills. When maintained properly, your equipment won't have to run as much because humidified air feels warmer in the winter.

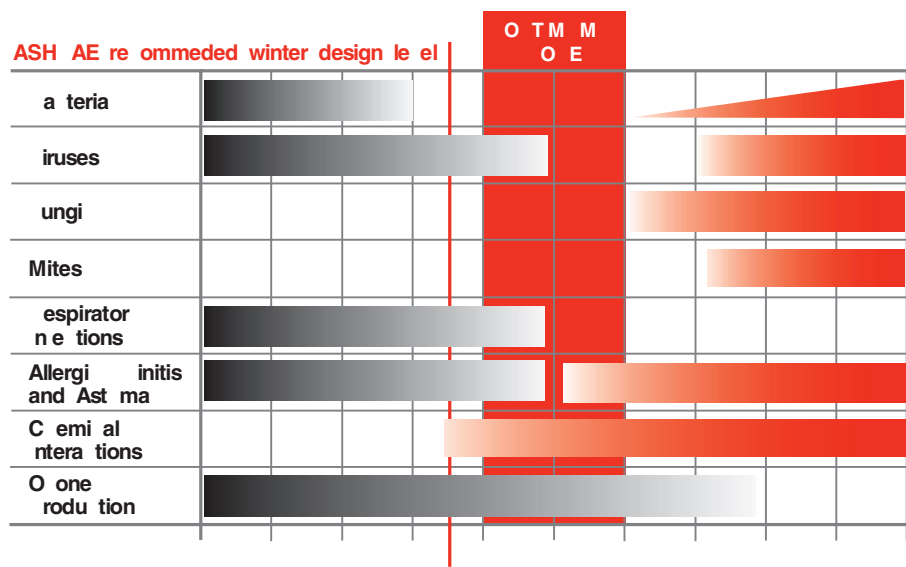

TrueSTEAM function and operation

Your TrueSTEAM humidifier provides the highest capacity and most efficient steam humidification for whole-house residential applications.

LED light feedback allows you to monitor performance, giving you total control and peace of mind.

True steam provides your home with high-capacity true humidity, while using up to 70% less water than flow-through humidifiers.

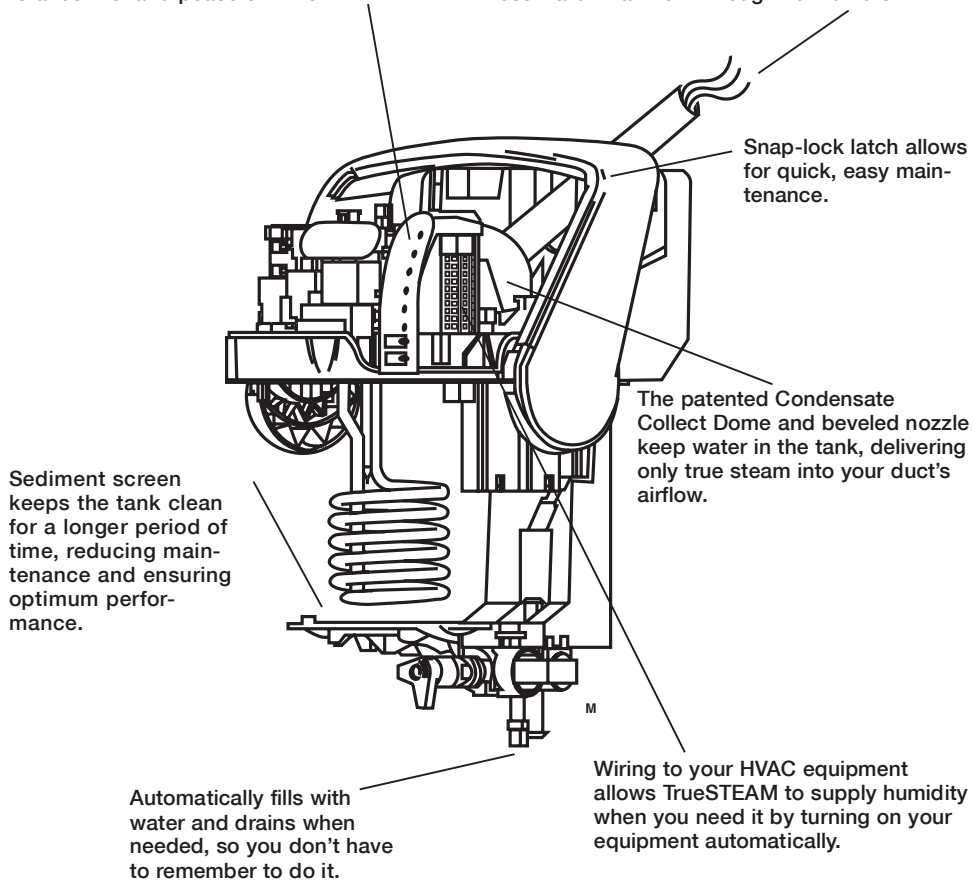

Setting the controls

The colder it is outside, the less humidity can be retained by the air. Initially setting your humidistat to ideal comfort levels will help your TrueSTEAM deliver optimal humidification. The table below provides suggested control settings based on outdoor conditions.

You may experience that your home needs humidity levels to be slightly higher or lower than the suggested levels given in the table, in order to prevent window condensation or dryness. This is because your home is unique in size, shape, building tightness, and age. These variables play an active role in how your indoor humidity fluctuates. Use the table as a starting point, but adjust according to your comfort and observations of condensation.

Outdoor Temperature	Recommended RH % Setting
-20°F (-29°C)	15%
-10°F (-23°C)	20%
0°F (-18°C)	25%
10°F (-12°C)	30%
20°F (-7°C)	35%
>20°F (-1°C)	40%

With automatic controls like TrueIAQ and VisionPRO IAQ, you need only calibrate this setting once. The automatic feature will adjust by itself as outdoor conditions change, based on your initial settings. After setting your auto control to the desired RH% level, check for condensation or frost forming on windows on the first cold day. If present, adjust your frost settings on the control (see control owner's manual if needed).



The Window Frost Protection feature protects your home by limiting humidity output based on outdoor conditions (for example, on colder days, your home can hold less humidity).



Frost Settings should be lowered by one value each morning that you see frost or condensation on windows. Allow 24 hours for the adjustment to take affect. Once you have this set to a comfortable level without condensation forming, you will not need to adjust this again. You can adjust your humidity settings without worrying about condensation.

With Manual Humidity Controls—such as the H8908—you will need to adjust your RH% settings each time the outdoor conditions change (more humidity with warmer outdoor conditions, lower humidity with colder conditions). These controls provide accurate operation, but require more hands on adjustment. These controls are a good choice for homeowners who desire continuous interaction with humidity settings.



LED light indicators

The LED light panel on the TrueSTEAM lets you know that the humidifier is operating correctly, when maintenance is needed, and when it is safe to remove the tank for cleaning. The push buttons allow the tank to be drained for cleaning, and quickly return to operation when the tank is reattached to the humidifier.

Power indicates the TrueSTEAM is plugged in and that the humidifier is ready for operation.

Humidifying indicates that steam is being delivered to the home.

Clean Tank: This LED blinks to indicate the TrueSTEAM is draining when you press the EMPTY button. When the light is on solid (not blinking), the tank is empty and safe to remove for cleaning.

Call Service is a fault indicator. Call your HVAC technician to service the humidifier. **HVAC technicians:** Refer to page 12 for fault identification and troubleshooting.

Press Reset will blink when power is applied or reapplied (upon initial installation or after cleaning). This is a stand-by mode to ensure water lines are hooked up properly before unit resumes operation. This will blink for 5 minutes before going to system ready. The 5-minute default can be overridden by the installer by pressing the RESET button.

Press Empty will blink to indicate that the water tank needs cleaning. Push the EMPTY button to drain the tank for safe removal and cleaning.

Reset Button If the Press Reset light is blinking, press the RESET button to override the 5-minute delay at startup. If the Call Service LED is on (fault is present), press/release the RESET button to blink a diagnostic code on the Call Service LED. Press/hold the button for 5 seconds to clear all faults and reset "Clean Tank" timers. If the Press Empty LED is blinking, press/hold the RESET button for 5 seconds to turn off the Press Empty LED and restart the Clean tank timer.

Empty Button Press and hold for 3 seconds to drain the tank of water for service. Do this before servicing the tank and internal parts.

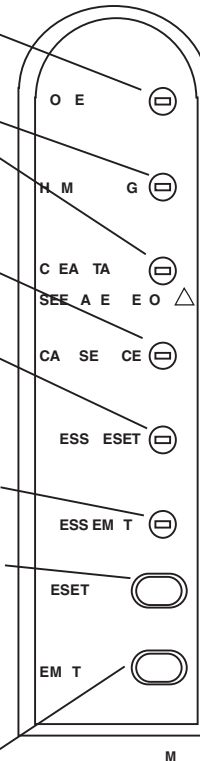

Cleaning and maintenance

Maintenance is made simple with the TrueSTEAM—just remove the water tank for cleaning.



Warning: Scalding hazard.

Do not attempt to remove the humidifier from the mounting bracket during operation, or the humidifier's water tank when full of water. The heating element could be hot when tank is removed. Failure to comply could result in severe scalding or death.



CAUTION

Hot water temperature above 140°F (60°C) can cause burns from scalding.

Drain Operation

- Auto flushing is configurable to 10, 20 or 30 hours of operational time (heating element active).
- During auto flushing, cold water will enter the tank to lower water temperature below 140°F (60°C) before draining.
- During manual flush (performed by pressing the EMPTY button) initial water temperature may be above 140°F (60°C). Ensure drain outlet is not exposed and use caution when pressing the EMPTY button, and do NOT attempt to remove the tank with water in it.
- Manual flush takes approximately 15 minutes to empty the tank completely.

To clean TrueSTEAM:

1. Press the EMPTY button. Wait for the CLEAN TANK light to be on solid (not blinking).

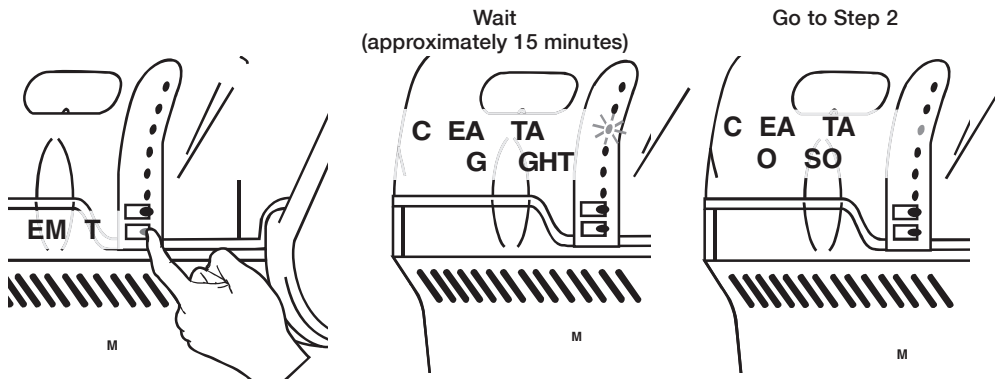

Cleaning and maintenance

- Turn the manual shut-off valve at the bottom of the tank to the "Unlock" position.

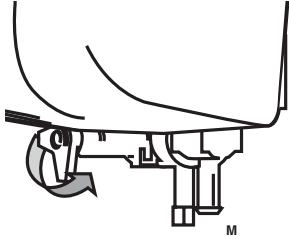

- Grip the white water valve arm and slide it back within the bracket to disengage from the tank.

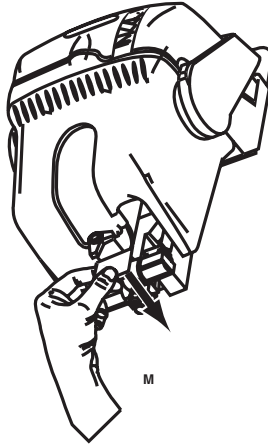

- Firmly grip the tank bottom. Push down the cover's safety button and pull the latch forward to release the tank.

Note: Latch does not come off humidifier with tank.

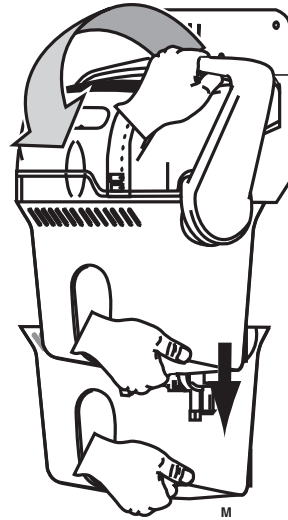

- Use tap water to flush loose minerals from the tank. Sediment screen at tank's bottom is removable. For a more thorough cleaning, soak tank in warm, soapy water, then rinse clean. Tank is also dishwasher-safe.

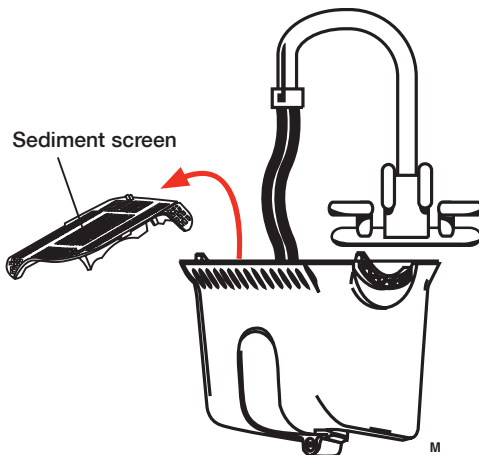

- Carefully rub minerals off of the heating element and reservoir walls. Scouring pads suitable for non-stick pots or pans are suitable for cleaning the TrueSTEAM reservoir walls and components within the tank.

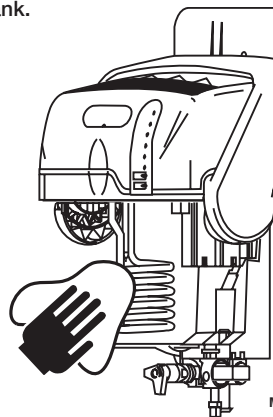

Once clean, reattach tank by securing the latch. Engage the water valve to the cam shaft, and "Lock" the shut-off valve. The "Press Reset" light will blink at start-up. Push the RESET button to ready the humidifier.

Seasonal or vacation maintenance

TrueSTEAM has the built-in intelligence to shut down when humidity is not needed for an extended period. After 48 hours of inactivity, TrueSTEAM will drain its tank and remain empty until it is needed again. This prevents water from stagnating within the tank. There are a few house-cleaning steps to follow to keep your TrueSTEAM at peak efficiency:

1. Follow steps 1–6 in the Cleaning section on pages 7–8 at least once per year, or when the Press Empty light is blinking.
2. Clear ventilation holes in the humidifier's cover.
3. Clear the water drain tube.
4. Make sure the water tank gasket seal is not cracked or split before reattaching the humidifier water tank.
5. Check that the humidifier is still level.

Extended Vacation

When you leave on extended vacations, it is recommended you turn off the humidifier's water supply and turn off the humidity control. When you return, turn on the humidifier water supply and reset your humidity control to a comfortable position.

Homeowner troubleshooting

If you have difficulty with TrueSTEAM, please try the following suggestions. Most problems can be corrected quickly and easily.

Problem	Look For	What to Do
Low humidity	Humidifier heater is not operating	<ul style="list-style-type: none"> • Confirm that power light is on. • Set the humidistat higher. • Check that the furnace power is on. • Reset your circuit breaker or check for blown fuse. • If fault persists, turn humidistat off, unplug unit, reset circuit breaker and call a professional HVAC contractor.
	Rapid air changes. Drafts (cold air is dry and is an added load for the humidifier)	<ul style="list-style-type: none"> • Keep doors and windows closed. • Close fireplace damper when not in use. • Keep exhaust fan running time to a minimum. • Seal around doors and windows.
High Humidity	Condensation on walls	<ul style="list-style-type: none"> • Turn off the humidity control until condensation is completely evaporated. Lower humidistat setting to prevent reoccurrence of condensation (see pages 2–4 for controlling humidity levels).
	Heavy condensation on windows	<ul style="list-style-type: none"> • Turn humidity control down low enough to eliminate condensation caused by moisture from bathing, mopping, cooking, etc. If moisture persists, more ventilation is needed.
Call for Service LED is blinking	TrueSTEAM has detected one of 15 system faults.	<ul style="list-style-type: none"> • Press Reset button. • If fault persists, turn off power supply to the humidifier, and turn back on. • If fault persists, call a professional HVAC contractor.

5-year limited warranty

Honeywell warrants this product to be free from defects in the workmanship or materials, under normal use and service, for a period of five (5) years from the date of purchase by the consumer. If at any time during the warranty period the product is determined to be defective or malfunctions, Honeywell shall repair or replace it (at Honeywell's option).

If the product is defective,

- (i) return it, with a bill of sale or other dated proof of purchase, to the place from which you purchased it; or
- (ii) call Honeywell Customer Care at 1-800-468-1502. Customer Care will make the determination whether the product should be returned to the following address: Honeywell Return Goods, Dock 4 MN10-3860, 1885 Douglas Dr. N., Golden Valley, MN 55422, or whether a replacement product can be sent to you.

This warranty does not cover removal or reinstallation costs. This warranty shall not apply if it is shown by Honeywell that the defect or malfunction was caused by damage which occurred while the product was in the possession of a consumer.

Honeywell's sole responsibility shall be to repair or replace the product within the terms stated above. HONEYWELL SHALL NOT BE LIABLE FOR ANY LOSS OR DAMAGE OF ANY KIND, INCLUDING ANY INCIDENTAL OR CONSEQUENTIAL DAMAGES RESULTING, DIRECTLY OR INDIRECTLY, FROM ANY BREACH OF ANY WARRANTY, EXPRESS OR IMPLIED, OR ANY OTHER FAILURE OF THIS PRODUCT. Some states do not allow the exclusion or limitation of incidental or consequential damages, so this limitation may not apply to you.

THIS WARRANTY IS THE ONLY EXPRESS WARRANTY HONEYWELL MAKES ON THIS PRODUCT. THE DURATION OF ANY IMPLIED WARRANTIES, INCLUDING THE WARRANTIES OF MERCHANTABILITY AND FITNESS FOR A PARTICULAR PURPOSE, IS HEREBY LIMITED TO THE FIVE-YEAR DURATION OF THIS WARRANTY. Some states do not allow limitations on how long an implied warranty lasts, so the above limitation may not apply to you.

This warranty gives you specific legal rights, and you may have other rights which vary from state to state.

If you have any questions concerning this warranty, please write Honeywell Customer Relations, 1985 Douglas Dr, Golden Valley, MN 55422 or call 1-800-468-1502. In Canada, write Retail Products ON15-02H, Honeywell Limited/Honeywell Limitée, 35 Dynamic Drive, Toronto, Ontario M1V4Z9.

Automation and Control Solutions

Honeywell International Inc.

1985 Douglas Drive North

Golden Valley, MN 55422

<http://yourhome.honeywell.com>

Honeywell Limited-Honeywell Limitée

35 Dynamic Drive

Toronto, Ontario M1V 4Z9



Printed in U.S.A. on recycled paper containing at least 10% post-consumer paper fibers.

© U.S. Registered Trademark.
© 2007 Honeywell International Inc.
Patents pending.
69-2035EFS—03 M.S. Rev. 11-07

Honeywell