

T8400B,C; T8401C Electronic Thermostats

INSTALLATION INSTRUCTIONS

T8400B Thermostat provides single-stage, non-programmable temperature control for 24V heat-only applications. Heating cycle rate is selectable at 1, 3, 4, 5, 6, 9, or 12 cph. Temperature indication can be set for °F or °C.

The T8400B Thermostat is powered through the heating system controls.

The T8400C and T8401C Thermostats provide single-stage, non-programmable temperature control for 24V heating-cooling systems with manual changeover from heat to cool. Heating cycle rate is selectable at 1, 3, 6, 9, or 12 cph. Cooling cycle rate is fixed at 3 cph. Temperature indication can be set for °F or °C.

The T8400C Thermostat is powered through the heating/cooling system controls. The T8401C Thermostat is powered directly from the system transformer.

Batteries are not required because setpoints are held permanently by nonvolatile memory for all models.

All models include a thermostat, wallplate (for wiring and mounting thermostat) and Owner's Guide. Two decorator cover plates (for covering wall marks) are included for select models.



MERCURY NOTICE

If this control is replacing a control that contains mercury in a sealed tube, do not place your old control in the trash. Dispose of properly.

Contact your local waste management authority for instructions regarding recycling and the proper disposal of an old control.

INSTALLATION

When Installing this Product...

1. Read these instructions carefully. Failure to follow them could damage the product or cause a hazardous condition.
2. Check the ratings given in the instructions and on the product to make sure the product is suitable for your application.
3. Installer must be a trained, experienced service technician.
4. After installation is complete, check out product operation as provided in these instructions.



CAUTION

Electrical Shock or Equipment Damage Hazard.

Can shock individuals or short equipment circuitry.

Disconnect power supply before installation.

Location

Install the thermostat about 5 ft (1.5m) above the floor in an area with good air circulation at average temperature. See Fig. 1. Do not install the thermostat where it can be affected by:

- drafts or dead spots behind doors and in corners.
- hot or cold air from ducts.
- radiant heat from the sun or appliances.
- concealed pipes and chimneys.
- unheated (uncooled) areas such as an outside wall behind the thermostat.

This thermostat is a precision instrument and was carefully adjusted at the factory. *Handle it carefully.*



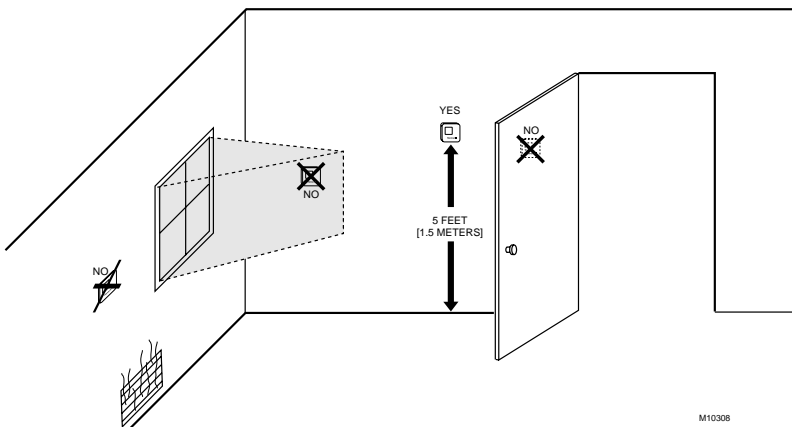

Fig. 1. Typical location of thermostat.

Mounting Wallplate and Decorator Cover Plate (Select Models) to Wall

IMPORTANT

Level only for appearance. The thermostat functions normally even when not level.

NOTE: All models include a thermostat, wallplate (for wiring and mounting thermostat) and Owner's Guide. Two decorator cover plates (to cover wall marks) are included for select models.

Mount wallplate and decorator cover plate (select models) as follows (see Fig. 2):

1. Place the desired decorator cover plate and the wallplate at the desired location on the wall.
2. Pull the thermostat wire through the entrance hole on the decorator cover plate, then through the wallplate entrance hole.
3. Select the two mounting holes that best fit the application.
4. Fasten the decorator cover plate and the wallplate to the wall using the anchors and screws provided.
5. After wiring the wallplate, plug the hole to prevent drafts from affecting the thermostat; see Wiring section.

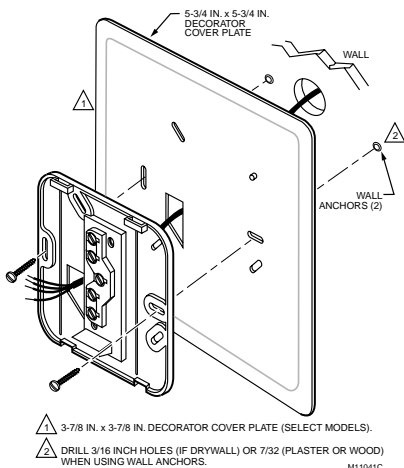

Fig. 2. Mounting decorator cover plate and wallplate to wall.

Wiring

IMPORTANT

Use an 18-gauge maximum wire for wiring the T8400B,C and T8401C Thermostats.

All wiring must comply with local electrical codes and ordinances. Disconnect the power supply to prevent electrical shock or equipment damage.

NOTE: To ensure proper mounting of thermostat, restrict all wiring to the shaded area on the left side of the terminals. See Fig. 3.

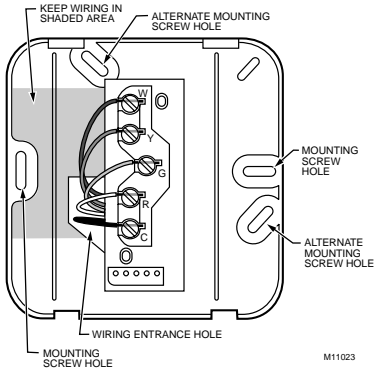

Fig. 3. Restrict wiring to shaded area.

The shape of the terminals permits insertion of straight or wraparound wiring connections; either method is acceptable. See Fig. 4.

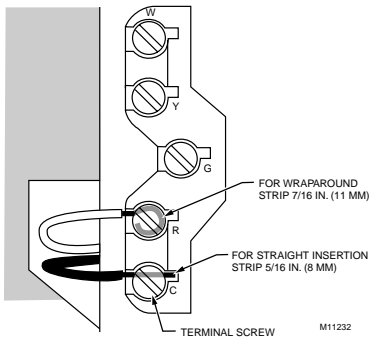

Fig. 4. Wiring connections.

The T8400B Thermostat is powered through the heating system control. The T8400B is adaptable to most 2-wire and 3-wire 18 to 30 Vac heating systems. Refer to Fig. 5 and 6 for typical wiring hookups.

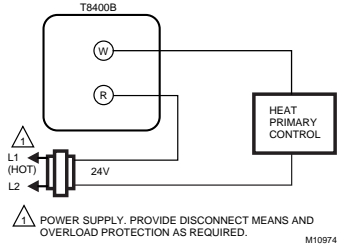

Fig. 5. T8400B heat-only wiring diagram in a single transformer system with gas heat.

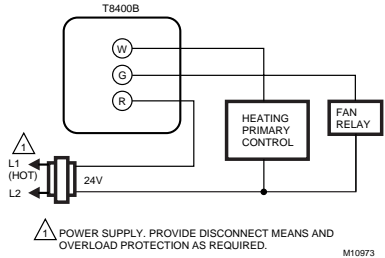

Fig. 6. T8400B heat-only wiring diagram in a single transformer system with gas heat.

The T8400C Thermostat is powered through the heating/cooling system controls and is adaptable to most 4-wire, 18 to 30 Vac heating-cooling systems.

The T8401C Thermostat is powered directly from the system transformer and is adaptable to most 5-wire, 18 to 30 Vac heating-cooling systems. Refer to Fig. 7 and 8 for typical wiring hookups.

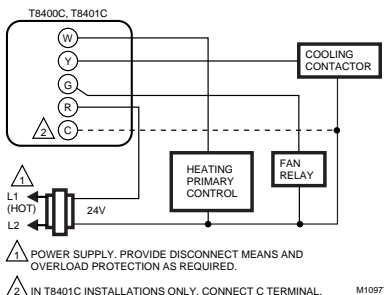

Fig. 7. T8400C/T8401C heat-cool wiring diagram in single transformer system with gas heat/electric cooling.

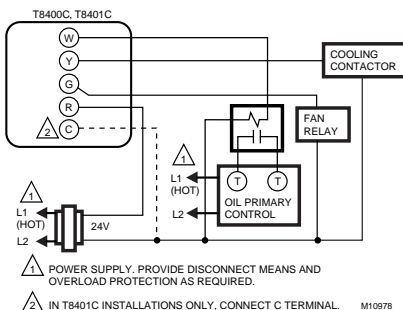

Fig. 8. T8400C/T8401C heat-cool wiring diagram in oil heating/electric cooling system. Oil primary has its own transformer.

Mounting Thermostat to Wallplate

1. Engage the tabs at the top of the thermostat and wallplate.
2. Swing down the thermostat and press the lower edge of the thermostat onto the wallplate to latch. See Fig. 9.

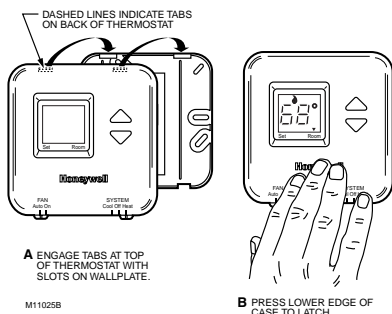

Fig. 9. Mounting thermostat to wallplate. T8400C shown here.

OPERATION

Setting FAN and SYSTEM Switches

Fan and system settings are controlled manually by using the switches located at the bottom of the thermostat case. See Fig. 10.

NOTE: Switch availability is model dependent.

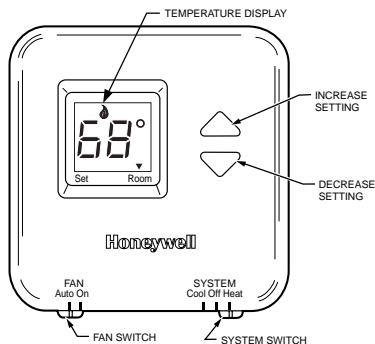

Fig. 10. T8400C Digital Display and Switches.

FAN Switch (Not Available on all Models)

Fan switch settings are:

Auto: Normal setting for most homes. In cooling, the fan starts and stops with the cooling equipment. In heating, the fan is controlled directly by the heating equipment and may start a few minutes after the heating equipment turns on (on most systems). When using an electric heat thermostat, the fan starts and stops with the heating equipment.

On: The fan runs continuously. Use for improved air circulation and air quality.

Slide the switch in the bottom left corner of the thermostat to select the desired fan setting.

SYSTEM Switch

System switch settings control thermostat operation as follows:

Cool: The thermostat controls the cooling system.

Off: Heating and cooling are off.

Heat: The thermostat controls the heating system.

NOTE: Cool Setting availability is model dependent.

Slide the switch in the bottom right corner of the thermostat to select the desired system setting.

Set Temperature Setpoint

NOTE: Temperature setpoint range is 40° to 99°F (5° to 37°C).

The setpoint temperature and the room temperature are shown separately on the digital display. The ▼ indicator points to **Set** when the setpoint temperature is displayed and to **Room** when the room temperature is displayed.

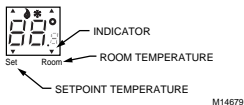

To set setpoint temperature:

1. Select Heat or Cool by sliding the system switch in the lower right corner of the thermostat to the desired mode. See Fig. 10.
2. To display the setpoint temperature on the digital display, press either the ▲ or ▼ key once. The setpoint temperature is displayed for approximately five seconds as the indicator points to **Set** and flashes.



3. To increase the setpoint temperature, press the ▲ key. Each press changes the setpoint one degree; press and hold to change the setpoint several degrees.



4. To decrease the setpoint temperature, press the ▼ key. Each press changes the setpoint one degree; press and hold to change the setpoint several degrees.



Setting °F/°C Indication and Heat Cycle Rate

NOTE: To save changes to the °F/°C indication and the heat cycle rate, all seven steps must be completed.

To set the °F/°C indication and heat cycle rate:

1. If the temperature is displayed in °F, set the setpoint temperature to 52°F. If the room temperature is displayed in °C, set the setpoint temperature to 11°C.

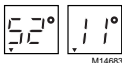

Optional System Checkout

When in steps 2 and 3 only, the ▼ key can be used to turn heat or cool outputs on and off. Change the system switch setting to test heat or cool outputs. No action takes place if the system switch is in the Off position.

Examples: System setting at HEAT: If heat is on, the ▼ key turns it off; if heat is off, ▼ turns it on.

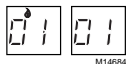

System setting at COOL: If cool is on, ▼ key turns it off; if cool is off, ▼ turns it on.

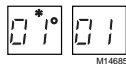

NOTE: The COOL setting is not available on all models.

2. Press the ▲▼ keys simultaneously for more than one second to light all segments on display and enter installer setup mode. When the keys are released, a two-digit software revision code is displayed.

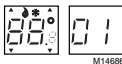

NOTE: In installer setup mode only, each press of the ▲ key momentarily displays 01. Each press of the ▼ key momentarily displays 02. When the keys are released, these two-digit codes are no longer displayed.

3. Press the ▲ key. Factory information is displayed. A typical example is shown, but information displayed varies by model. This information is for factory use only.



4. Press the ▲ key again to display °C or °F.



5. Press the ▼ key to change the °C or °F indication.



6. Press the ▲ key to display the heat cycle rate of 1, 3, 4, 5, 6, 9, or 12. If the desired cycle is displayed, press the ▲ key to exit the installer setup mode. To change the heat cycle rate, press the ▼ key to scroll between 1, 3, 4, 5, 6, 9, and 12. Stop scrolling when the desired rate is displayed. See Table 1 for the cycle rate options and the corresponding system equipment.



Table 1. Heating Cycle Rates.

System	Cycles Per Hour
Steam, Gravity	1
Hydronic Heat, Condensing Gas Furnaces ^a	3
Gas or Oil Forced Air	6
Electric Heat	9
Special Applications ^b	4, 5, 12

^a High Efficiency Furnace.

^b Refer to the equipment manufacturer's Instructions.

NOTE: Steps 7 and 8 are available on select models.

7. Press the ▲ key to display cooling algorithm configuration default.



8. Press the ▲ key to change cooling algorithm to C1 or C3.
 C1 = Standard cooling algorithm.
 C3 = Aggressive cooling algorithm (can cause overshooting).
9. Press the ▲ key to save all changes, exit installer setup mode and return to normal operation.

CHECKOUT

Heating

- Slide the SYSTEM switch to Heat. Slide the FAN switch to Auto, if available.
- Press and hold the ▲ key to raise the temperature setting several degrees above the room temperature. After approximately ten seconds, the heating equipment should start. In conventional systems, the system turns on the fan through the use of a time delay relay or through a limit control. When using an electric heat thermostat, the fan starts immediately.
- Press the ▼ key to lower the temperature setting below the room temperature. Heating equipment should stop.

Cooling (Not Available on all Models)



CAUTION

Low Temperature Hazard.
Operating at too low of an outdoor temperature may cause compressor damage.
 Do not operate cooling if outdoor temperature is below 50°F (10°C). Refer to equipment manufacturer's recommendations.

- Slide the SYSTEM switch to Cool and the FAN switch to Auto.
- Press the ▼ key to lower the temperature setting several degrees below the room temperature. After approximately five minutes, the cooling equipment should start. The fan starts and stops with the cooling equipment.
- Press the ▲ key to raise the temperature setting above the room temperature. Cooling system should shut down.

Fan (Not Available on all Models)

- Slide the SYSTEM switch to Off and the FAN switch to On. The fan should run continuously.
- Slide the FAN switch to Auto. In heating, the fan is controlled directly by the heating equipment and may start a few minutes after the heating equipment turns on (for most systems). When using an electric heat thermostat, the fan starts and stops with the heating equipment. In cooling, the fan starts and stops with the cooling equipment.

Make certain all equipment responds properly to the thermostat.

Honeywell

Automation and Control Solutions

Honeywell	Honeywell Limited-Honeywell Limitée
1985 Douglas Drive North	35 Dynamic Drive
Golden Valley, MN 55422	Scarborough, Ontario
	M1V 4Z9