

INSTALLER'S & OWNER'S MANUAL

HVAC INSTALLER: PLEASE LEAVE MANUAL FOR HOMEOWNER



Santa·Fe™ CLASSIC



New 3 Year Parts & Labor Limited Warranty!

- Free-standing dehumidification for your home.
- Includes installation, operating and safety instructions, warranty information and all ancillary products.
- Read and save these instructions.



P/N 4021400 • Serial No. _____ Install Date: _____

Sold by:



Therma-Stor[®] LLC

Driven by performance. Powered by design.™

P.O. Box 8680 Madison, WI 53708 • TOLL-FREE 1-800-533-7533 • www.thermastor.com • sales@thermastor.com

© 2008 Therma-Stor LLC • Manual P/N TS-192 4/08

TABLE OF CONTENTS

Table of Contents

1. Specifications	2
2. Installation.....	2
2.1 Location	2
2.1A In Humid Area, No Ducting.....	2
2.1B In Humid Area, Duct Inlet and/or Outlet	2
2.1C In Remote Area, Duct Inlet & Outlet.....	2
2.1D In Remote Area, Duct Outlet Only.....	3
2.1E In Remote Area, Duct Inlet Only	3
2.2 Electrical Requirements.....	3
2.3 Condensate Removal.....	3
2.4 Ducting.....	3
2.4A Optional Ducting	3
2.4B Ducting for Dehumidification.....	3
3. Operation.....	3
3.1 Humidity Control Adjustment	3
3.2 Blower Switch	3
4. Maintenance.....	3
4.1 Air Filter	3
5. Service	4
5.1 Warranty.....	4
5.2 Technical description.....	4
5.3 Troubleshooting.....	4
5.4 Refrigerant Charging	4
5.5 Blower Replacement.....	5
5.6 Compressor/Capacitor Replacement.....	5
5.6A Checking Compressor Motor Circuits	5
5.6B Replacing A Burned Out Compressor	5
5.6C Replacing a Compressor - Nonburn Out.....	6
5.7 Humidity Control.....	6
5.8 Defrost Thermostat.....	6
5.9 Condensate Pump	6
6. Wiring Diagram.....	7
7. Service Parts List.....	8
Optional Remote Humidity Control	9
Condensate Pump Installation Instructions.....	10
Ductable Inlet Mounting Detail.....	11
Muffler Kit Instructions	12
Filter Installation Instructions	13
Warranty.....	14

Read the installation, operation and maintenance instructions carefully before installing and using this unit. Proper adherence to these instructions is essential to obtain maximum benefit from your Santa Fe Classic dehumidifier.

When unpacking make sure to remove corrugated shipping cardboard from top of unit.



Specifications

Part Number:	4021400
Blower:	275 CFM @ 0.0" WG
Power:	760 watts @ 80°F and 60% RH
Supply Voltage:	115 volt – 1 phase - 60 Hz
Current Draw:	6.3 Amps
Energy Factor:	2.65 L/kWh
Operating Temp.:	45°F Min., 95°F Max.
Sized for:	2500 Sq. Ft. - Typical
Minimum Performance at 80°F and 60% RH	
Water Removal:	100 Pints/Day
Efficiency:	5.6 Pints/kWh
Air Filter:	MERV-11
Efficiency:	Standard 65% Efficient, ASHRAE Dust Spot Test
Size:	16" x 20" x 2"
Power Cord:	10', – 110-120 VAC, Ground
Drain Hose:	9/16" ID x 8' Direct Gravity Drain Hose

Santa Fe Dimensions

	Unit	With Duct Kit	Shipping
Width:	20"	23"	20"
Height:	36"	42 1/2"	43"
Depth:	17"	17"	24"
Weight:	110 lbs		117 lbs

CAUTION! — This symbol means important instructions. Failure to heed them can result in injury or material property damage.

2. Installation

2.1 Location

The Santa Fe Classic is designed to be installed indoors and is ideal for unfinished and finished basements.

CAUTION!

- Installation outdoors, in a crawlspace or near a pool or spa will void factory warranty.
- Do not use the dehumidifier as a bench or table.

2.1A In humid area, no ducting.

The simplest installation is to place the Santa Fe Classic in the humid area with no ducting. The air inlet on top & outlet on the side must be at least 1' from walls and other obstructions to air flow.

2.1B In humid area, duct inlet and/or outlet.

If the humid area is very large or has high ceilings, dehumidification can be improved by adding an inlet and/or outlet duct to circulate and destratify stagnant areas. For a large area, add inlet or outlet ducting to create flow across the

area's greatest length. For areas with ceilings higher than 12', use an inlet duct to draw warm, moist air from near the ceiling. See section 2.4 for attaching duct collars & ducting.

2.1C In A Remote Area, Duct Inlet & Outlet.

It is often desirable, especially in billiard rooms and finished areas, to install the Santa Fe Classic in an adjacent equipment room or unfinished area. Air is transferred between the humid room and the unit via ducting. The factory mounted humidity control on the Santa Fe Classic cabinet may not sense the humidity in the humid room accurately enough with this installation method. If so, an additional humidity control can be mounted in the humid room and wired to the Santa Fe Classic. Local electrical codes must be followed when wiring the control.

2.1D In A Remote Area, Duct Outlet Only.

A simpler remote installation method than above uses ducting between the Santa Fe Classic discharge and the humid room; the Santa Fe Classic inlet draws air from the room in which it's located. This works well if there is an adequate air flow path between the two rooms; e.g. high door undercut, louvered door or wall grill. This eliminates the need to remote mount the humidity control. There are several potential disadvantages to using this method. First, humid air is drawn into the room where the Santa Fe Classic is located. Second, to accurately sense humidity, the blower in the Santa Fe Classic may need to run continuously to draw air from the humid room into the Santa Fe Classic room. Third, a slight negative pressure is created in the room with the Santa Fe Classic which could back draft open combustion devices located there. If such devices are present, call the factory for specific instructions before using this installation method or consider the option below.

2.1E In A Remote Area, Duct Inlet Only.

When the Santa Fe Classic is located in a room separate from the main area to be dehumidified, it may be desirable to dehumidify and/or slightly pressurize that room. Pressurization assures that open combustion devices do not back draft. This can be accomplished by installing a duct from the humid room to the Santa Fe Classic inlet and by allowing the Santa Fe Classic to discharge dehumidified air into the room in which it's located. An adequate air flow path must exist between the two rooms for this method to work well. An additional humidity control may need to be mounted in the humid area and wired to the Santa Fe Classic to accurately maintain the desired humidity. Local electrical codes must be followed when wiring the control.

2.2 Electrical Requirements

The Santa Fe Classic plugs into a common grounded outlet on a 15 Amp circuit. It draws between 6 and 7 Amps under normal operating conditions.

2.3 Condensate Removal

Condensate drains by gravity via the clear hose extending from the unit. Route hose to a floor drain. Use care to keep the hose as flat to the floor as possible. Excessive humps or kinks will prevent proper drainage.

If the Santa Fe Classic is located too far from a floor drain for the attached hose to reach, 1/2" PVC pipe can be used to extend it. It is commonly available in 10' lengths from building supply, plumbing and hardware stores. It will slide tightly inside the end of the drain hose.

If more than one length of pipe is required they can be joined with a short piece cut from the end of the drain hose.

2.4 Ducting

2.4A Optional Ducting

An inlet shroud with an 8" round collar and an 8" round exhaust collar are available from the factory that will allow round ducting to be attached to the inlet and/or outlet of the Santa Fe Classic.

2.4B Ducting for Dehumidification

Ducting the Santa Fe Classic as mentioned in sections 2.1B-2.1E requires consideration of the following points:

Duct Sizing: For total duct lengths up to 25 feet, use a minimum 8" diameter round or equivalent rectangular. For longer lengths, use a minimum 10" diameter or equivalent. Grills or diffusers on the duct ends must not excessively restrict air flow. **Isolated Areas:** Effective dehumidification may require that ducting be branched to isolated, stagnant areas. Use 6" diameter branch ducting to each of two or three areas, use 4" to each of four or more areas.

3. Operation

3.1 Humidity Control Adjustment

The dehumidifier will run continuously until relative humidity (RH) is reduced to the humidity control dial setting. Setting the humidity control to lower RH levels will **NOT** increase the unit's dehumidification rate, it will simply run longer to reduce the area's RH to the setting. The Santa Fe Classic unit (and refrigerant based dehumidifiers in general) will reduce a warm space's RH to a lower level than that of a cool space. For example, the Santa Fe Classic may reduce an 80° F space to 30% RH. However, if the same space is 65° F, it may only reduce it to 40% RH. It is therefore pointless to set the humidity control to excessively low levels in cool rooms. Doing so will result in long periods of ineffective dehumidifier run time. Quality humidity meters are available from the factory and are recommended to accurately monitor humidity levels.

3.2 Blower Switch

Turning "ON" the fan switch will cause the unit's internal blower to run continuously, whether the unit is dehumidifying or not. This function is desirable if the unit is used for air circulation.

4. Maintenance

4.1 Air Filter

The Santa Fe Classic is equipped with 2 air filters. A foam pre-filter followed by a standard MERV-11 65% efficient pleated fabric filter. These should be checked every six months. Operating the unit with dirty filters will reduce dehumidifier capacity and

efficiency and may cause the compressor to cycle off and on unnecessarily on the defrost control.

If dirty, the foam pre-filter can be vacuumed or carefully hand washed with warm water and mild detergent, then rinsed. The pleated fabric filter can generally be vacuumed clean several times before needing replacement. Replacement filters can be ordered from the factory or purchased locally if available. **DO NOT** operate the unit without the filters or with a less effective filter. The heat exchange coils inside the unit could become clogged and require disassembly to clean.

5. Service

CAUTION!

Servicing the Santa Fe Classic with its high pressure refrigerant system and high voltage circuitry presents a health hazard which could result in death, serious bodily injury, and/or property damage. Only qualified service people should service this unit.

5.1 Warranty

A warranty certificate has been enclosed with this unit. Read it before any repair is initiated. If a warranty repair is required, call the factory first at 1-800-533-7533 for warranty claim authorization and technical assistance.

5.2 Technical Description

The Santa Fe Classic uses a refrigeration system similar to an air conditioner's to remove heat and moisture from incoming air, and add heat to the air that is discharged (see figure 1).

Hot, high pressure refrigerant gas is routed from the compressor to the condenser coil (see figure 1). The refrigerant is cooled and condensed by giving up its heat to the air that is about to be discharged from the unit. The refrigerant liquid then passes through a filter/drier and capillary tubing which cause the refrigerant pressure and temperature to drop. It next enters the evaporator coil where it absorbs heat from the incoming air and evaporates

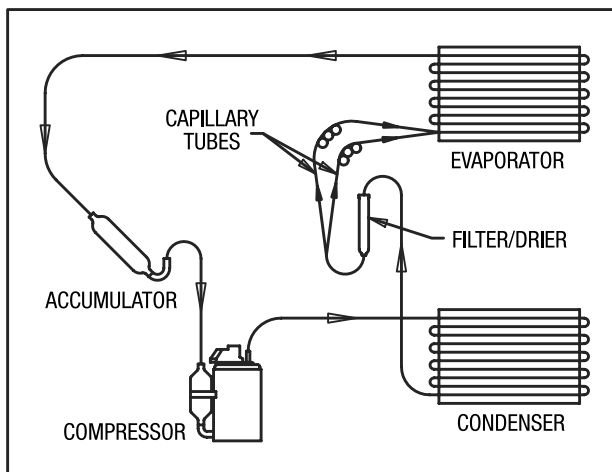

The evaporator operates in a flooded condition, which means that all the evaporator tubes contain liquid refrigerant during normal operation. A flooded evaporator should maintain constant pressure and temperature across the entire coil, from inlet to outlet.

The mixture of gas and liquid refrigerant enter the accumulator after leaving the evaporator coil. The accumulator prevents any liquid refrigerant from reaching the compressor. The compressor evacuates the cool refrigerant gas from the accumulator and compresses it to a high pressure and temperature gas to repeat the process.

5.3 Troubleshooting

No dehumidification. Neither blower nor compressor run with fan switch "FAN AUTO".

1. Unit unplugged or no power to outlet.
2. Humidity control set too high or defective (Sec. 3.1 & 5.7).
3. Loose connection in internal wiring.

No dehumidification. Compressor does not run but blower runs with fan switch "FAN AUTO" and humidity control turned to ON (all the way clockwise).

1. Defective compressor or compressor run capacitor (Sec. 5.6).
2. Loose connection in compressor circuit (see Fig. 2).
3. Defective compressor overload (Sec. 5.6A).
4. Defective compressor (Sec. 5.6).
5. Defrost thermostat open (Sec. 5.8).

Blower runs with fan switch "FAN AUTO", but compressor cycles ON & OFF.

1. Low ambient temperature and/or humidity causing unit to cycle through defrost mode.
2. Defective compressor overload (Sec. 5.6A).
3. Defective compressor (Sec. 5.6).
4. Defrost thermostat defective (Sec. 5.8).

Blower does not run with fan switch in either position. Compressor runs briefly but cycles ON & OFF.

1. Loose connection in blower circuit (see Fig. 2).
2. Obstruction prevents impeller rotation.
3. Defective blower.
4. Blower switch defective.

Evaporator coil frosted continuously, low dehumidifying capacity.

1. Defrost thermostat loose or defective (Sec. 5.8).
2. Low refrigerant charge.
3. Dirty air filter or air flow restricted.

5.4 Refrigerant Charging

If the refrigerant charge is lost due to service or a leak, a new charge must be accurately weighed in. If any of the old charge is left in the system, it must be removed before weighing in the new charge. Refer to the unit nameplate for the correct charge weight and refrigerant type.

5.5 Blower Replacement

The centrifugal blower has a PSC motor and internal thermal overload protection. If defective, the complete assembly must be replaced.

1. Unplug the power cord.
2. If an outlet duct is connected to the unit, remove it.
3. Remove the cabinet side.
4. Remove the 4 screws holding the electrical box located next to the blower.
5. Disconnect the blower leads. Black from the blower switch, and white from the run capacitor.
6. Unbolt the blower capacitor from the blower motor (required for removal clearance).
7. Remove the nuts & bolts holding the blower outlet flange to the cabinet end and remove the blower.
8. Reassembling with the new blower is the above procedure reversed.

5.6 Compressor/Capacitor Replacement

This compressor is equipped with a two terminal external overload run capacitor, but no start capacitor or relay (see Fig. 2).

CAUTION!

ELECTRIC SHOCK HAZARD: Electrical power must be present to perform some tests; these tests should be performed by a qualified service person.

5.6A Checking Compressor Motor Circuits

Perform the following tests if the blower runs but the compressor does not with the blower switch OFF and the humidity control ON.

1. Unplug the unit, remove the cabinet side (with two screws in center) and the electrical connection cover on the compressor top.
2. Plug in the unit and turn the humidity control to ON. Check for 110 volts from compressor terminal R to overload terminal 3 using an AC voltmeter. If voltage is present, go to step 3. If no voltage, the high pressure control or relay are open or there is a loose connection in the compressor circuit. Test each component for continuity; see the appropriate section if a defect is suspected.
3. Unplug the unit, then disconnect the red and yellow wires from compressor terminals R & S. Using an ohmmeter, check continuity between the points listed below.
4. Compressor terminals C and S: No continuity indicates an open start winding. The compressor must be replaced. Normal start winding resistance 3 to 7 ohms.
5. Compressor terminals C and R: No continuity indicates an open run winding. The compressor must be replaced. Normal run winding resistance is .5 to 2 ohms.
6. Compressor terminal C and overload terminal 1: No continuity indicates a defective overload lead.

7. Overload terminals 1 and 3: If there is no continuity, the overload may be tripped. Wait 10 minutes and try again. If there is still no continuity, it is defective and must be replaced.
8. Compressor terminal C and compressor case: Continuity indicates a grounded motor. The compressor must be replaced.
9. Disconnect the yellow wires from the capacitor. Set the ohmmeter to the Rx1 scale. The capacitor is shorted and must be replaced if continuity exists across its terminals. If there is no needle movement with the meter set on the Rx100000 scale, the capacitor is open and must be replaced.
10. Reconnect the wires to the compressor and capacitor. Plug in and turn on the unit. If the compressor fails to start, replace the run capacitor.
11. If the unit doesn't start, adding a hard-start kit (relay & capacitor) will provide greater starting torque. If this doesn't work, the compressor has an internal mechanical defect and must be replaced.

5.6B Replacing a Burned Out Compressor

The refrigerant and oil mixture in a compressor is chemically very stable under normal operating conditions. However, when an electrical short occurs in the compressor motor, the resulting high temperature arc causes a portion of the refrigerant oil mixture to break down into carbonaceous sludge, a very corrosive acid and water. These contaminants must be carefully removed otherwise even small residues will attack replacement compressor motors and cause failures.

The following procedure is effective only if the system is monitored after replacing the compressor to insure that the clean up was complete.

1. This procedure assumes that the previously listed compressor motor circuit tests revealed a shorted or open winding. If so, cautiously smell there frigerant from the compressor service port for the acid odor of a burn out.
2. Remove and properly dispose of the system charge. DO NOT vent the refrigerant indoors or allow it to contact your eyes or skin.
3. Remove the burned out compressor. Use rubber gloves if there is any possibility of contacting the oil or sludge.
4. To facilitate subsequent steps, determine the type of burn out that occurred. If the discharge line shows no evidence of sludge and the suction line is also clean or perhaps has some light carbon deposits, the burn out occurred while the compressor was not rotating. Contaminants are therefore largely confined to the compressor housing. A single installation of liquid and suction line filter/driers will probably clean up the system.

If sludge is evident in the discharge line, it will likely be found in the suction line. This indicates the compressor burned out while running. Sludge and acid has been pumped throughout the system. Several changes of the liquid and suction filter/driers will probably be necessary to cleanse the system.

5. Correct the system fault that caused the burn out. Consult the factory for advice.
6. Install the replacement compressor with a new capacitor and an oversized liquid line filter. In a running burn out, install an oversized suction line filter/drier between the accumulator and compressor. Thoroughly flush the accumulator with refrigerant to remove all trapped sludge and to prevent the oil hole from becoming plugged. A standing burn out does not require a suction line filter/drier.
7. Evacuate the system with a good vacuum pump and accurate vacuum gauge. Leave the pump on the system for at least an hour.

An alternate method of removing moisture and non-condensibles from the system requires evacuation to 29" Hg vacuum. Then break the vacuum with 35 to 50 PSIG refrigerant vapor charge. Leave the vapor charge in the system from at least 5 minutes before removing it. Repeat the vapor charge/wait/remove sequence twice more and then charge the system with the quantity and refrigerant listed on the nameplate.

8. Operate the system for a short period of time, monitoring the suction pressure to determine that the suction filter is not becoming plugged. Replace the suction filter/drier if pressure drop occurs. If a severe running burn out has occurred, several filters/driers may have to be replaced to remove all of the acid and moisture.

NOTE: NEVER use the compressor to evacuate the system or any part of it.

5.6C Replacing a Compressor - Nonburn Out

Remove the refrigerant from the system. Replace the compressor and liquid line filter/drier. Charge the system to 50 PSIG and check for leaks. Remove the charge and weigh in the refrigerant quantity listed on the nameplate. Operate the system to verify performance.

5.7 Humidity Control

The humidity control is an adjustable switch that closes when the relative humidity of the air in which it is located rises to the dial set point. It opens when the RH drops 4 to 6% below the set point.

5.8 Defrost Thermostat

The defrost thermostat is attached to the refrigerant suction tube between the accumulator and compressor. It will automatically shut the compressor off if the low side refrigerant temperature drops due to excessive frost formation on the evaporator coil. The blower will continue to run, causing air to flow through the evaporator coil and melt the ice. When the ice has melted, the evaporator temperature will rise and the thermostat will restart the compressor.

5.9 Condensate Pump

Condensate is automatically pumped to a remote location when the water level in the pump's reservoir rises to close the float switch.

SANTA FE CLASSIC WIRING DIAGRAM

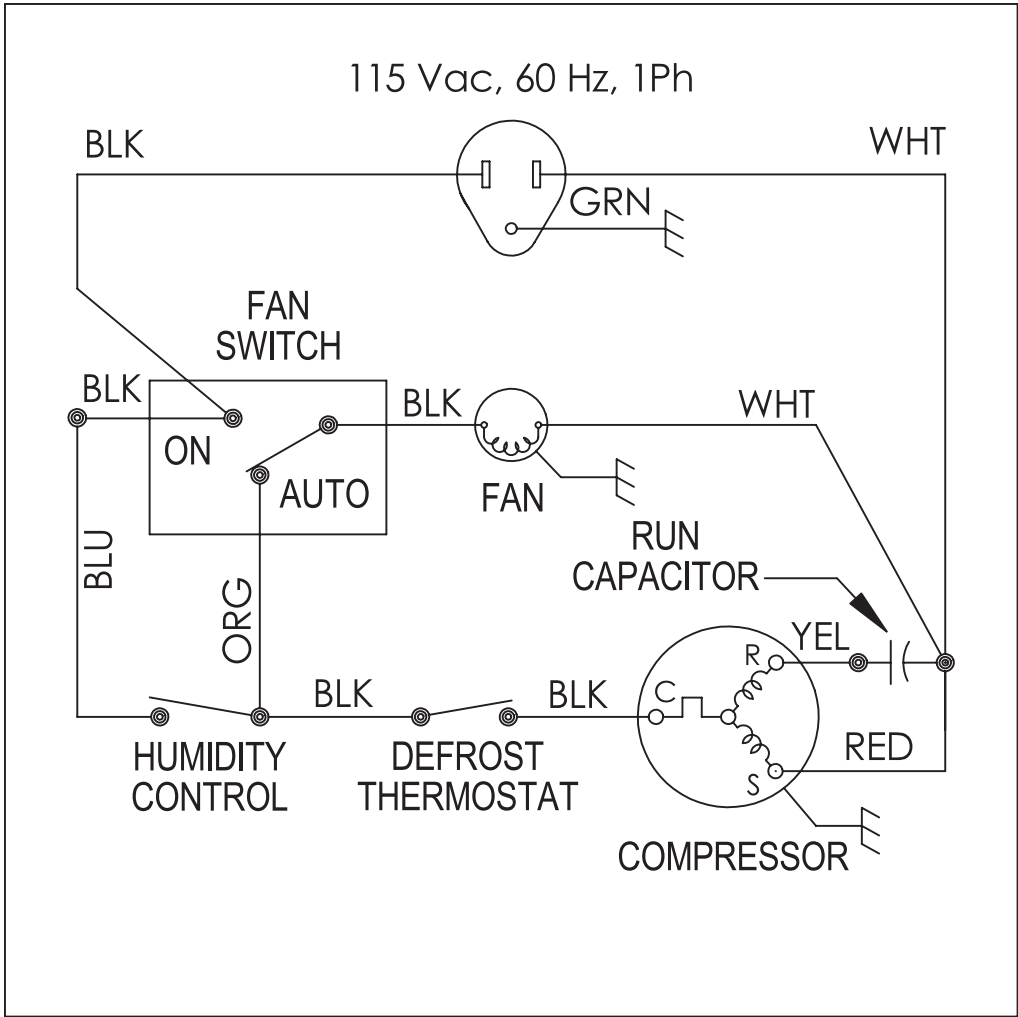
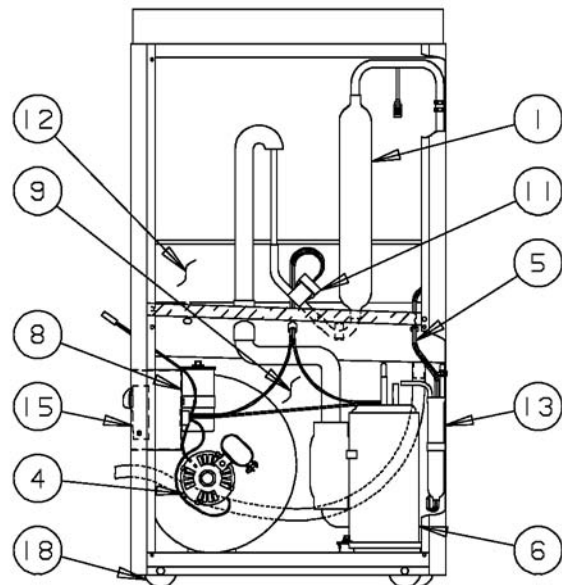
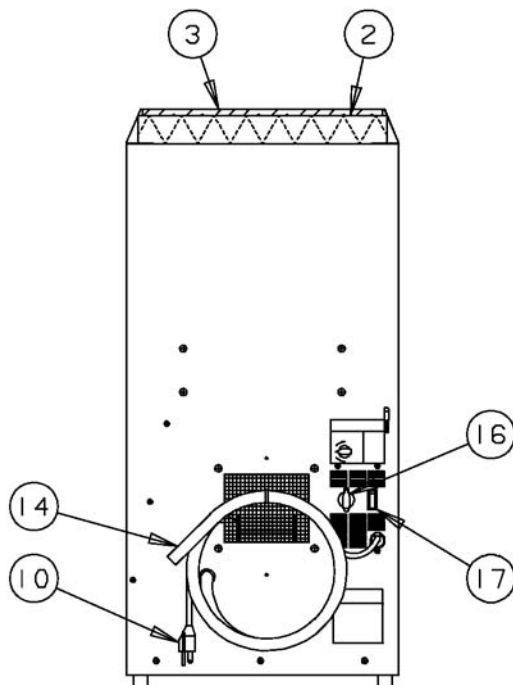

Figure 2: Electrical Schematic of the Santa Fe Classic Dehumidifier

SANTA FE CLASSIC SERVICE PARTS LIST • To order contact your reseller or call 1-800-533-7533

ITEM	PART NO.	QTY.	DESCRIPTION
1	4022254	1	Accumulator
2	4021475	1	Air Filter, Pleated, 2" x 16" x 20"
3	4021468	1	Air Filter, Foam Element
4	4022037	1	Blower w/ Capacitor
5	4021589	2	Capillary Tubes, .050" ID x 28" long
6	4023474	1	Compressor, Panasonic (2R12S3R126A-6A)
7	4022144	1	Compressor Overload (TI # MRA98706-673; not shown)
8	4024666	1	Compressor Run Capacitor for Panasonic, 35 MFD, 370V
9	4021396	1	Condenser Coil
10	4021409	1	Cord & Wire Harness
11	4021470	1	Defrost Thermostat
	4021648	1	Defrost Thermostat Mounting Clip (item 11)
12	4021395	1	Evaporator Coil
13	4025087	1	Filter/Drier
14	4021626	1	Hose, Drain, .56" ID x 8'
15	4021469	1	Humidity Controller
16	4021495	1	Knob, Humidity Controller
17	4025560	1	Switch, SPDT, for Fan
18	4021471	4	Wheel, 2", Plastic
19	4021507	1	Wiring Diagram (on cover; not shown)
20	4021453	1	Optional Ducting Kit (for inlet & outlet; not shown)
21	4020623	1	Optional Outlet Collar (for ducting outlet only; not shown)
22	4022220	1	Condensate Pump Kit (see page 10)
23	4021586	1	Ductable Inlet Kit (see page 12)
24	4022561	1	Silencer Kit (see page 13)



CAUTION!

This should only be performed by a qualified electrician.

A 110-120 VAC remote humidity control is available from the factory. This replaces the factory mounted humidity control on the cabinet of the dehumidifier, and allows the unit to accurately sense the humidity in an area other than the one where the unit is located.

1. Unplug the unit.
2. Pull the black humidity control knob off from the side of the unit, exposing 2 screws. Remove the screws.
3. Remove the front panel of the dehumidifier by removing 6 screws.
4. Remove the 4 screws securing the wiring box to the inside of the blower end of the dehumidifier, and pull the box away from the cabinet to allow access.
5. Insert a romex connector or conduit connector into the hole in the cabinet that is left after the dehumidistat is removed. Pass the cable to be used to connect to the remote dehumidistat through the connector.
6. Disconnect the dehumidistat leads and reconnect with the new wires.
7. Replace the wiring box and screws. Replace the front cover and screws. Tighten any loose screws on the connector.
8. Run the new wire to the location desired to sense relative humidity. Install a 110-120 VAC dehumidistat according to local electrical codes.

SANTA FE CLASSIC CONDENSATE PUMP INSTALLATION INSTRUCTIONS



STEP 1: The condensate pump kit includes: drain hose, condensate pump, two mounting screws and instructions.



STEP 2: Pre-drilled mounting holes are located near the bottom and on the same side of the unit as the drain hose.



STEP 3: Secure the condensate pump to the unit with the two provided screws.

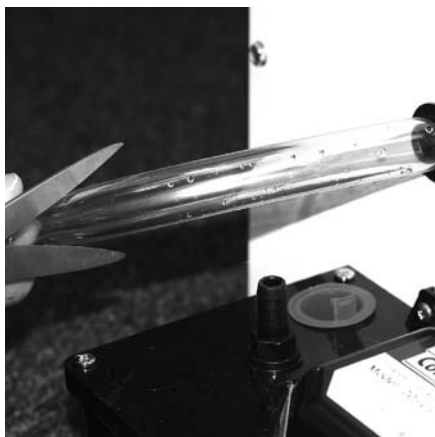

STEP 4: Cut the condensate drain hose at a 45° angle approximately 10 inches from the unit.

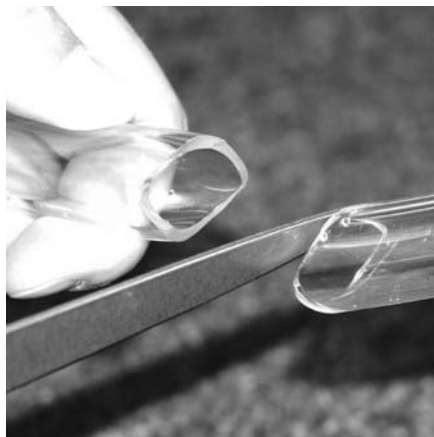

STEP 5: Example of hose cut at a 45° angle. The angle prevents the hose from sealing tight against the bottom of the pump reservoir.

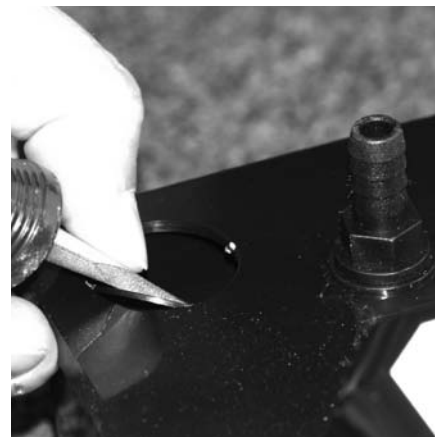

STEP 6: Remove the plug as shown.



STEP 7: Insert the drain hose into the condensate pump reservoir as shown.

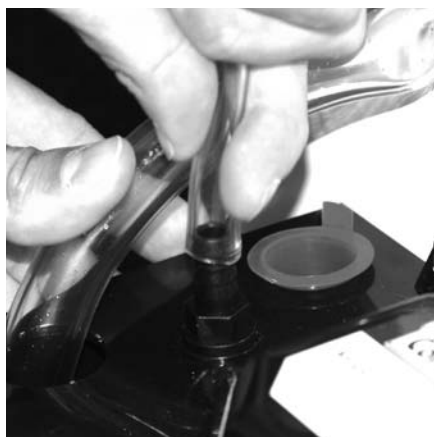

STEP 8: Install the provided drain hose over the condensate pump nipple.



STEP 9: Route the condensate pump drain hose to an appropriate drain and plug the condensate pump into a standard 115VAC outlet.

SANTA FE CLASSIC DUCTABLE INLET MOUNTING

Ductable Inlet Instructions

1. Remove the Filters from the unit.
2. Remove the ductable inlet from the box and remove the release paper from the tape on the inlet flanges.
3. Center the inlet above the filter guides and attach the inlet to the guides.
4. Replace the filters in the unit.

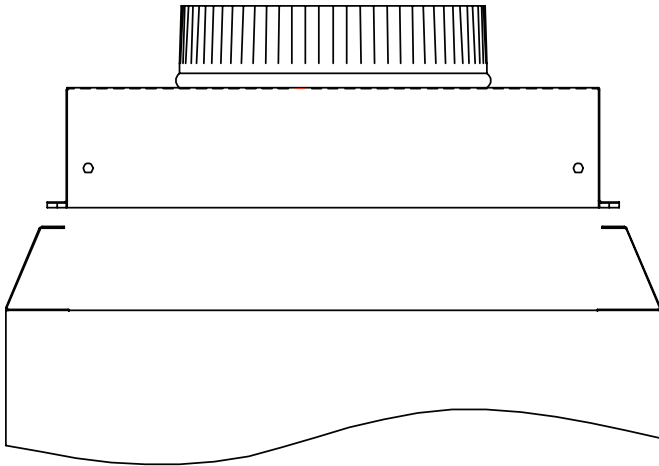

Exhaust Collar Mounting Instructions

5. The six inch opening may be used as a fresh air inlet from outside.
6. Remove the exhaust collar from the box and bend the tabs in.
7. Place the collar over the blower outlet and line up the tabs with the holes in the cabinet.
8. Using (4) screws from the kit, attach the collar to the unit.

Ductable Inlet

Exhaust Collar

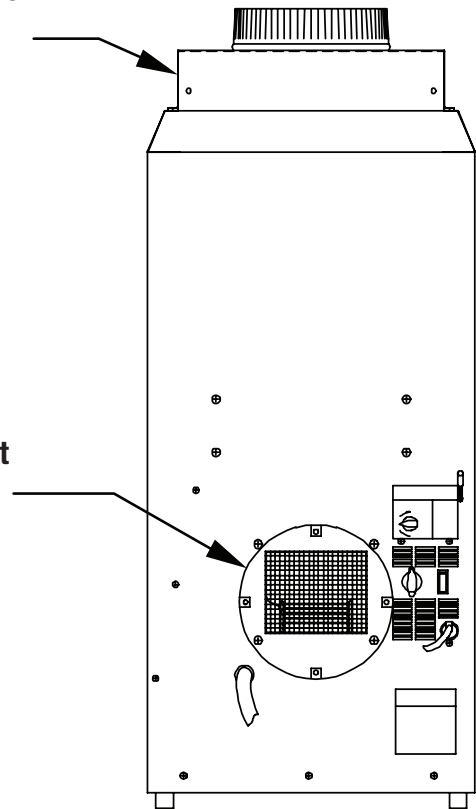

SANTA FE CLASSIC MUFFLER KIT INSTRUCTIONS

Component List

- (1) Silencer
- (1) #8-18 Screw
- (1) Instructions

Note: Washer and (2) screws are not used on the Santa Fe Classic.

On the Santa Fe Classic, the muffler kit and condensate pump kit may be used together, but the pump will not be able to be mounted to the unit.

Loosen these (2) screws enough to slide the silencer under the screw heads.

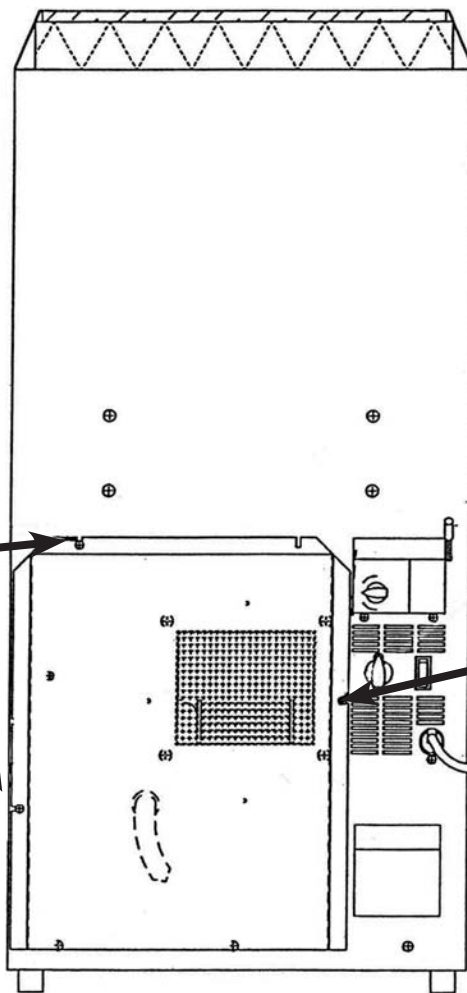

Insert (1) screw from the enclosed parts and tighten.

Santa Fe Classic Muffler Kit Installed



SANTA FE CLASSIC FILTER INSTALLATION INSTRUCTIONS

Instructions: To prevent damaging the foam filter, place it “grid side up” on top of the pleated filter and slide them both into the filter slot.

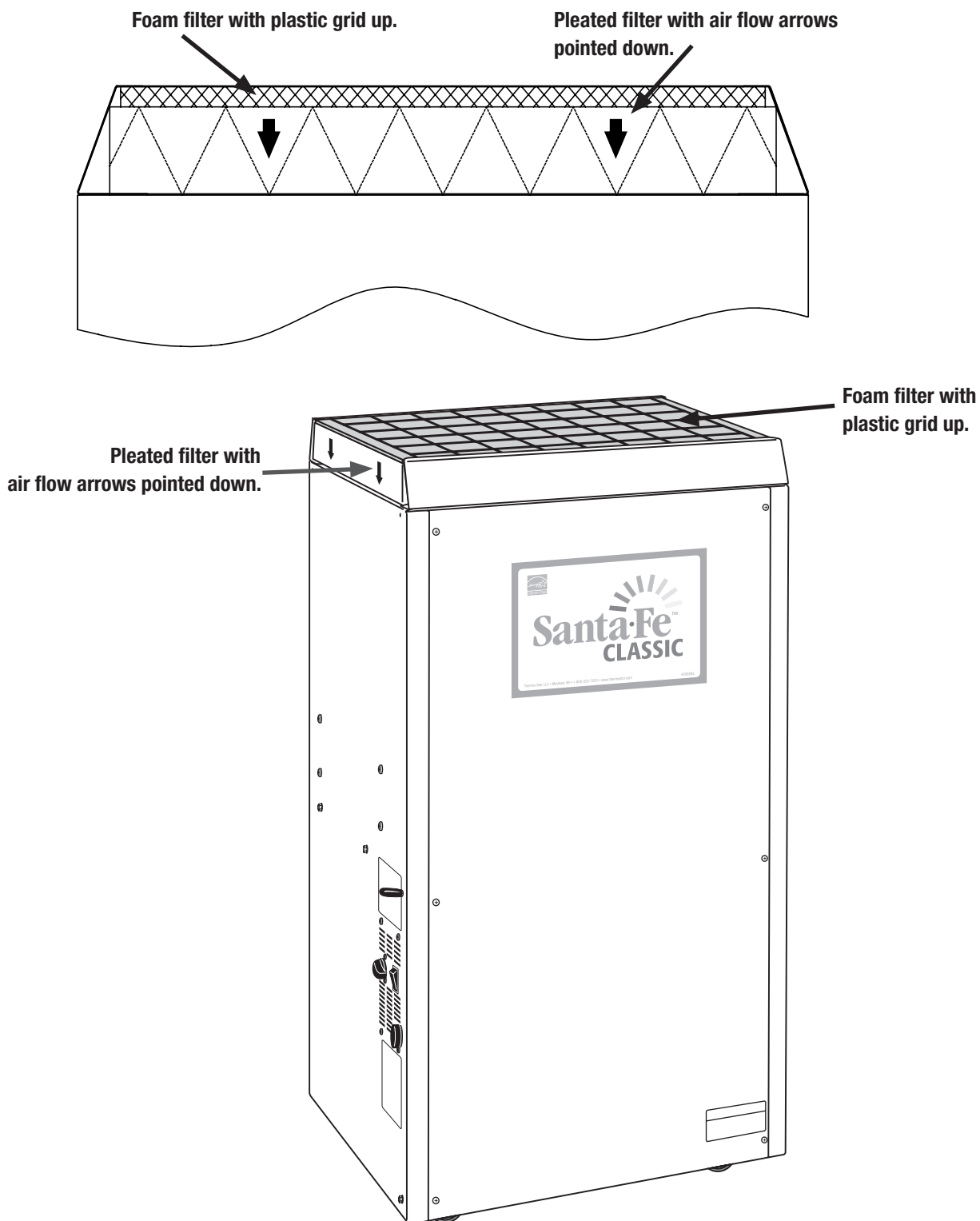



Santa Fe™ CLASSIC Limited Warranty

Limited Warranty. Therma-Stor, LLC (“Therma-Stor”) warrants as follows: (i) the Santa Fe Classic dehumidifier (“Product”) will be free of material defects in workmanship or materials for a period of three (3) years (“Three-Year Warranty”) following the date of initial purchase of such Product by an original customer purchasing from Therma-Stor or an authorized reseller (“Customer”); and (ii) the Product’s condenser, evaporator, and compressor will be free of material defects in workmanship or materials for a period of five (5) years following the date of initial purchase of such Product by a Customer.

Limitation of Remedies. CUSTOMER’S SOLE AND EXCLUSIVE REMEDY UNDER THE ABOVE LIMITED WARRANTY AND THERMA-STOR’S ENTIRE LIABILITY THEREUNDER, SHALL BE, AT THE SOLE OPTION OF THERMA-STOR, REPLACEMENT OR REPAIR OF SUCH PRODUCT OR ITS COMPONENTS (“COMPONENTS”) BY THERMA-STOR OR THERMA-STOR’S AGENTS ONLY. REFRIGERANT, PIPING, SUPPLIES, TRANSPORTATION COSTS, LABOR COSTS INCURRED IN REPAIR OR REPLACEMENT OF SUCH COMPONENTS ARE NOT INCLUDED. THIS DISCLAIMER AND EXCLUSION SHALL APPLY EVEN IF THE EXPRESS WARRANTY AND LIMITED REMEDY SET FORTH HEREIN FAILS OF ITS ESSENTIAL PURPOSE. CUSTOMER ACKNOWLEDGES THAT NO REPRESENTATIVE OF THERMA-STOR OR OF ITS AFFILIATES OR RESELLERS IS AUTHORIZED TO MAKE ANY REPRESENTATION OR WARRANTY ON BEHALF OF THERMA-STOR OR ANY OF ITS AFFILIATES OR RESELLERS THAT IS NOT IN THIS AGREEMENT. Notwithstanding the above, during the term of the Three-Year Warranty only, Therma-Stor will provide, free of charge to Customer, all Components and labor (except costs related to removal and installation of Product) required to fulfill its obligations under such Three-Year Warranty.

Disclaimer of Warranties. EXCEPT FOR ABOVE LIMITED WARRANTY, WHICH IS THE SOLE AND EXCLUSIVE WARRANTY PROVIDED WITH RESPECT TO THE PRODUCT AND ITS COMPONENTS, THERMA-STOR HEREBY DISCLAIMS ALL EXPRESS AND IMPLIED WARRANTIES, INCLUDING, WITHOUT LIMITATION, THE IMPLIED WARRANTIES OF MERCHANTABILITY AND FITNESS FOR A PARTICULAR PURPOSE.

Warranty Limitations. The foregoing limited warranty extends only to a Customer and shall be null and void upon attempted assignment or transfer. A “defect” under the terms of the limited warranty shall not include problems resulting from Customer’s or Customer’s employees’, agents’, invitees’ or a third party’s misuse, improper installation, improper design of any system in which the Product is included, abuse, lack of normal care, failure to follow written instructions, tampering, improper repair, or freezing, corrosion, acts of nature or other causes not arising out of defects in Therma-Stor’s workmanship or material. If a Product or Component is replaced while under warranty, the applicable limited warranty period shall not be extended beyond the original warranty time period. The limited warranty does not cover any costs related to changes to a Product or Component that may be required by any codes, laws, or regulations that may become effective after initial purchase of the Product by Customer.

Customer Responsibilities. As a further condition to obtaining warranty coverage hereunder, the Customer must send a valid warranty claim to Therma-Stor such that Therma-Stor receives such claim prior to the end of the applicable warranty period. Therma-Stor shall have no obligation hereunder with respect to any claim received by Therma-Stor after the expiration of the applicable warranty period. As a further condition to obtaining warranty coverage hereunder, the Customer must present forms of invoices evidencing proof of purchase of a Product. If such invoices do not clearly indicate the date of initial purchase by a Customer, the applicable Product’s date of manufacture will be used instead of the date of initial purchase for the purpose of calculating the commencement of the applicable warranty period. Warranty service must be performed by Therma-Stor or a servicer authorized by Therma-Stor. In order to obtain warranty service, the Customer should call Therma-Stor at 1-800-533-7533 and ask for the Therma-Stor Products Service Department, which will then arrange for applicable warranty service. Warranty service will be performed during customary, daytime working hours. If the Product must be shipped for service, Customer shall be solely responsible for properly packaging the Product, for all freight charges, and for all risk of loss associated with shipment.

Limitation of Liability. IN NO EVENT SHALL THERMA-STOR, IN CONNECTION WITH THE DESIGN, SALE, INSTALLATION, USE, REPAIR, REPLACEMENT OR PERFORMANCE OF ANY PRODUCT, COMPONENT, PART THEREOF OR WRITTEN MATERIAL PROVIDED THEREWITH, BE LIABLE, TO THE EXTENT ALLOWED UNDER APPLICABLE LAW, UNDER ANY LEGAL THEORY FOR ANY SPECIAL, DIRECT, INDIRECT, COLLATERAL OR CONSEQUENTIAL DAMAGES OF ANY KIND. NOTWITHSTANDING THE ABOVE LIMITATIONS AND WARRANTIES, THE SOLE AND EXCLUSIVE LIABILITY OF THERMA-STOR, REGARDLESS OF THE NATURE OR THEORY OF THE CLAIM, SHALL UNDER NO CIRCUMSTANCES EXCEED THE PURCHASE PRICE OF THE PRODUCT, COMPONENT OR PART UPON WHICH THE CLAIM IS PREMISED.

Applicable Law and Venue. ANY ARBITRATION, ENFORCEMENT OF AN ARBITRATION OR LITIGATION RELATED TO THE PRODUCT WILL BE BROUGHT EXCLUSIVELY IN DANE COUNTY, WISCONSIN, AND CUSTOMER CONSENTS TO THE JURISDICTION OF THE FEDERAL AND STATE COURTS LOCATED THEREIN, SUBMITS TO THE JURISDICTION THEREOF AND WAIVES THE RIGHT TO CHANGE VENUE. CUSTOMER FURTHER CONSENTS TO THE EXERCISE OF PERSONAL JURISDICTION BY ANY SUCH COURT WITH RESPECT TO ANY SUCH PROCEEDING.

Miscellaneous. If any term or condition of this Limited Warranty is found by a court of competent jurisdiction to be invalid, illegal or otherwise unenforceable, the same shall not affect the other terms or conditions hereof or thereof or the whole of this Limited Warranty. Any delay or failure by Therma-Stor to exercise any right or remedy will not constitute a waiver of Therma-Stor to thereafter enforce such rights.



Therma-Stor LLC

PO Box 8680 • Madison, WI 53708

Phone: 608-222-5301 • Fax: 608-222-1447

Web: www.thermastor.com • Email: sales@thermastor.com

Information in this document is subject to change without notice. No part of this document may be reproduced or transmitted in any form or by any means, electronic or mechanical, for any purpose, without the express written permission of Therma-Stor LLC. © 2008 Therma-Stor LLC. All rights reserved.
