

INSTALLER'S & OWNER'S MANUAL

HVAC INSTALLER: PLEASE LEAVE MANUAL FOR HOMEOWNER



Santa·Fe™ Rx



- Free-standing dehumidification for your home.
- Includes installation, operating and safety instructions, warranty information and all ancillary products.
- Read and save these instructions.

P/N 4023673 • Serial No. _____ Install Date: _____

Sold by:



Therma-Stor[®] LLC

Driven by performance. Powered by design.™

P.O. Box 8680 Madison, WI 53708 • TOLL-FREE 1-800-533-7533 • www.thermastor.com • sales@thermastor.com

© 2008 Therma-Stor LLC • Manual P/N TS-235e

TABLE OF CONTENTS

Table of Contents

1. Specifications	2
2. Installation	2
2.1 Location	2
2.2 Electrical Requirements	2
2.3 Condensate Removal	3
2.4 Optional Reservoir Container	3
2.5 Safety Overflow Switch	3
3. Operation	3
3.1 Top Removal	3
3.2 Humidity Control Adjustment	3
3.3 Power Switch	3
4. Maintenance	3
4.1 Air Filter	3
4.1A Filter Options	4
4.1B Optional Filter Test	4
5. Service	4
5.1 Warranty	4
5.2 Technical description	4
5.3 Troubleshooting	4
5.4 Refrigerant Charging	5
5.5 Blower Replacement	5
5.6 Compressor/Capacitor Replacement	5
5.6A Replacing A Burned Out Compressor	6
5.6B Replacing a Compressor - Nonburn Out	6
5.7 Humidity Control	6
5.8 Defrost Thermostat	6
5.9 Condensate Pump	6
5.10 Relay	6
5.11 Low Pressure Control	6
Wiring Diagram	7
Service Parts List	8
Filter Frame Assembly	9
Set-Up Instructions	10
Warranty	11

Read the installation, operation and maintenance instructions carefully before installing and using this unit. Proper adherence to these instructions is essential to obtain maximum benefit from your Santa Fe Rx Dehumidifier.

1. Specifications

Part Number:	4023673
Blower:	230 CFM @ 0.0" WG
Power:	630 Watts @ 80°F and 60% RH
Supply Voltage:	115 volt – 1 phase – 60 Hz
Current Draw:	5.4 Amps
Energy Factor:	2.45 l/kw
Operating Temp.:	45°F Min., 95°F Max. (70°F recommended)
Sized for:	2200 Sq. Ft. - Typical
Minimum Performance at 80°F and 60% RH	
Water Removal:	74 Pints/Day
Efficiency:	5.2 Pints/kWh
Air Filter:	MERV-11
Efficiency	Standard 65% Efficient, ASHRAE Dust Spot Test
Size:	16" x 20" x 2'
Power Cord:	10' – 110-120 VAC, Ground
Drain Hose:	3/16" ID x 20' of drain hose with 15' lift capacity; Internal Pump Included

Santa Fe Rx Dimensions

	Dimensions	Dimensions with Secondary Filter Housing	Shipping
Width:	23"	23"	29"
Height:	37-1/2"	37-1/2"	46"
Depth:	20"	24-5/8"	29"
Weight:	130 lbs		172 lbs.

 **CAUTION!** — This symbol means important instructions. Failure to heed them can result in injury or material property damage.

SAFETY PRECAUTIONS

2. Installation

2.1 Location

The Santa Fe Rx is designed to be installed indoors. Ideal for living spaces and finished basements.

CAUTION!

- Installation outdoors, in a crawlspace or near a pool or spa will void factory warranty.
- Do not use the dehumidifier as a bench or table.

Consider the following points when choosing a location for your Santa Fe Rx:

1. The Santa Fe Rx is most effective if it is centrally located in the space to be dehumidified.
2. It is designed to be placed with its back 3" or more from a wall (the air outlet is located at the lower portion of the back). This will reduce noise and the likelihood that discharge air will blow directly at someone.
3. The water removed by the Santa Fe Rx will be pumped through the 20' long hose coming from under its base. The hose (about the diameter of a TV coaxial cable) must be routed to a drain or outside. It can pump condensate 15' above the unit and can be extended (see section 2.3).
4. The top can serve as a light duty table (maximum load: 20 lbs.), but it must be removed periodically to check the air filter.

2.2 Electrical Requirements

The Santa Fe Rx plugs into a common grounded outlet on a 15 Amp circuit. It draws between 5 and 6 Amps under normal operating conditions.

2.3 Condensate Removal

The Santa Fe Rx is equipped with a condensate pump to remove the water that is condensed during dehumidification. This allows the water to be discharged to a distant location, or to be pumped up to 15' above the Santa Fe Rx.

The water is discharged through a 20' hose coming from the unit bottom. The hose is about the diameter of a TV coaxial cable and can be routed in much the same way. If a drain is not convenient, a small hole can be drilled through the floor or wall to access a drain or outside. The hose can be extended if needed; it should, however, be extended with a hose of larger inner diameter (1/4" I.D. or greater) to avoid overloading the pump. Larger diameter hose is available from the factory or may be purchased from many hardware stores. If the hose can not be routed to a drain or outside, a reservoir container with an overflow switch can be used.

If the hose is routed outside, it must exit the building with a downward slant. This will allow the water in the hose to drain from it when the pump shuts off, preventing it from freezing.

Pump failure will cause the unit to stop dehumidifying via a safety switch.

2.4 Optional Reservoir Container

If the condensate discharge hose cannot be routed to a drain or outside, it can empty into a conveniently located container. This container (supplied by the customer) can be any size greater than 1/2 gallon. It can be emptied manually or by a pump (supplied by the customer).

CAUTION: It is strongly recommended that a safety overflow switch be used to prevent the container from overflowing and causing potentially costly water damage.

2.5 Safety Overflow Switch

A Safety Overflow Switch is available from the factory (see parts list). It consists of a float switch on a weighted cord with a male-female piggyback plug. The cord is secured to the container with the float and weight inside; the weight is separated from the float and container wall.

3 Operation

3.1 Top Removal

The top of the unit must be removed to access the humidity control knob, blower switch, and standard air filter. The standard metal top is removed by pulling it horizontally toward the front about 3/4", then lifting it upward (the unit front is opposite from the side that the air comes out).

3.2 Humidity Control Adjustment

The humidity control knob is located under the removable top (top must be lifted off to access). Turning the knob clockwise lowers humidity. Turning it counter clockwise to the stop shuts it off.

The dehumidifier will run continuously until the relative humidity (RH) is reduced to the humidity control setting. Setting the humidity control to lower RH levels will NOT increase the unit's dehumidification rate, it will simply run longer to reduce the area's RH to the setting.

The Santa Fe Rx (and refrigerant based dehumidifiers in general) will reduce a warm space's RH to a lower level than that of a cool space. For example, the Santa Fe Rx may reduce an 80°F space to 30% RH. However, if the same space is 65°F, it may only reduce to a 40% RH.

A humidity meter is supplied upon return of the survey warranty registration card: a meter is recommended to accurately monitor humidity levels. Additional meters are available for purchase from the factory.

3.3 Blower Switch

Lifting off the top accesses the blower switch. It is located near the humidity control dial.

Turning the blower switch to **FAN ON** will cause the blower to run continuously, whether the unit is dehumidifying or not. This function is desirable if the unit is used for air filtering.

4. Maintenance

4.1 Air Filter

The Santa Fe Rx is equipped with a standard MERV 11 65% efficient disposable pleated fabric air filter. Optional 95% efficiency, 99.97% efficiency HEPA grade and activated carbon filters are available (see Section 4.1A).

The standard filter is located beneath the removable top. The filter is removed by lifting the front edge up first, then the back. It should be checked every 6 months. Operating the unit with a dirty filter will reduce dehumidifier capacity and efficiency. If dirty, the pleated fabric filter can generally be vacuumed cleaned several times before needing replacement. Replacement filters can be ordered from the factory or purchased locally if available. Its nominal size is 16" x 20" x 2" thick. Its efficiency is 65% per ASHRAE std. 52.1-1992.

DO NOT operate the unit without the filter or with a less effective filter. The heat exchange coils inside the unit could become clogged which would reduce performance and require disassembly to clean.

4.1A Filter Options

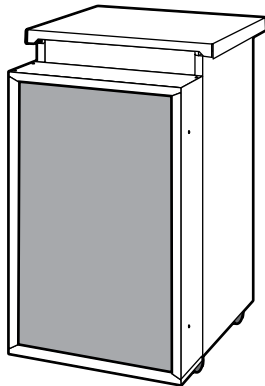

*Santa Fe Rx with
Optional Filter Frame Attached
to Back*

An optional filter frame is available that attaches to the back of the machine and adds 6-1/2" to the units' depth. It allows the choice of using either 95% efficient, HEPA grade, or activated carbon filters in addition to the standard filter. These filters are accessible by removing the 4 screws from the filter frame top cover.

The MERV 14 **95% efficient filters** (as rated by ASHRAE 52-76 Dust Spot Test) capture about 95% of all particles greater than 1 micron. Actual filter size is 19.38" wide x 15.38" high x 3.75" deep.

Two filters are stacked to form a 32" high filter bank. These filters can be tested for replacement using the optional filter test listed in Section 4.1B.

The **HEPA media filter** captures 99.97% of all particles 0.3 microns or larger that pass through it. Actual filter size is 19.38" wide x 30.75" high x 3.75" deep. These filters can be tested for replacement using the optional filter test listed in Section 4.1B.

Optional **Carbon filter/Pleated filter** combination: The carbon filter is actually a blend of activated carbon and potassium permanganate. This blend removes the vast majority of gaseous contaminants encountered in most filtering applications. The activated carbon removes the heavier volatile organics while the potassium permanganate removes the lower molecular weight contaminants. The life of this disposable filter depends upon both the hours used and the contamination level. The filter contains 8.7

pounds of active media (17.4 pounds with two filters).

Another advantage of this blend versus an all carbon filter is that it changes color as it loads up with contaminants. It starts out black, then turns pink, then brown, and finally white. It is best changed when it passes the brown stage and begins to turn white, as it has lost most of its effectiveness at that point. Actual filter size of the carbon filter is 19.38" wide x 15.38" high x 2.88" deep. The .88" deep pleated filter is the same nominal size and is installed downstream of the carbon dust. The two filter combos are stacked to form a 32" high filter bank.

4.1B Optional Filter Test

The optional 95% efficiency and HEPA filters have long lives when prefiltered by the standard MERV 11 65% efficient pleated inlet filter; they can last many years in certain conditions. How long they last can, however, vary widely depending upon the following: unit run time, air contamination level and standard inlet filter cleanliness. Given the expense of the optional filter, it can be costly to change them prematurely. The following test helps determine when they should be changed.

Air exiting the bottom rear of the unit enters the filter frame, then passes through the optional filter and into the room. If the filter is dirty, air pressure builds up before the filter. To check this pressure, remove the plastic plug from the filter frame top; you will feel air coming out of the hole with the unit running. Place the ping pong ball that came with the filter frame on the hole and let go (any marked, regulation sized ping pong ball will work). If the ball does not move or only bounces slightly and does not spin continuously, the filter is clean enough for continued use. If the ball floats above the hole and starts to spin and perhaps wobble within 30 seconds, the filter needs to be changed.

5. Service

⚠ CAUTION! Servicing the Santa Fe Rx with its high pressure refrigerant system and high voltage circuitry presents a health hazard which could result in death, serious bodily injury, and/or property damage. Only qualified service people should service this unit.

5.1 Warranty

A warranty certificate has been enclosed with this unit. Read it before any repair is initiated. If a warranty repair is required, call the factory first at 1-800-533-7533 for warranty claim authorization and technical assistance.

5.2 Technical Description

The Santa Fe Rx uses a refrigeration system similar to an air conditioner's to remove heat and moisture from incoming air, and add heat to the air that is discharged (see figure 1).

Hot, high pressure refrigerant gas is routed from the compressor to the condenser coil. The refrigerant is cooled and condensed by giving up its heat to the air that is about to be discharged from the unit. The refrigerant liquid then passes

FOR HVAC INSTALLER ONLY

through a filter/drier and capillary tubing which cause the refrigerant pressure and temperature to drop. It next enters the evaporator coil where it absorbs heat from the incoming air and evaporates.

The evaporator operates in a flooded condition, which means that all the evaporator tubes contain liquid refrigerant during normal operation. A flooded evaporator should maintain constant pressure and temperature across the entire coil, from inlet to outlet.

The mixture of gas and liquid refrigerant enter the accumulator after leaving the evaporator coil. The accumulator prevents any liquid refrigerant from reaching the compressor. The compressor evacuates the cool refrigerant gas from the accumulator and compresses it to a high pressure and temperature gas to repeat the process.

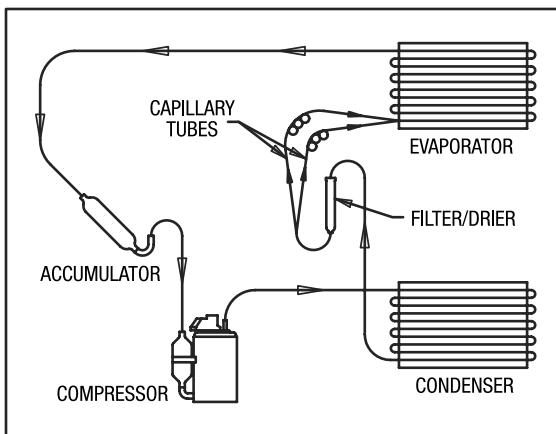

5.3 Troubleshooting

No dehumidification. Neither blower nor compressor run with AUTO FAN and humidity control turned ON.

1. Unit unplugged or no power to outlet.
2. Humidity control set too high or defective (Sec. 3.1 & 5.7).
3. Loose connection in internal wiring (Fig. 2).
4. Safety float switch in remote reservoir has turned unit off (Sec. 2.5).

No dehumidification. Compressor does not run but blower runs with AUTO FAN and humidity control turned to ON.

1. Defective compressor run capacitor (Sec. 5.6).
2. Loose connection in compressor circuit (see Fig. 2).
3. Defective compressor overload (Sec. 5.6A).
4. Defective compressor (Sec. 5.6).
5. Defrost thermostat open (Sec. 5.8).
6. Defective relay (Sec. 5.10).
7. Pump Safety switch open (Sec. 5.9)

Blower runs with AUTO FAN, but compressor cycles on & off.

1. Low ambient temperature and/or humidity causing unit to cycle through defrost mode.
2. Defective compressor overload (Sec. 5.6A).
3. Defective compressor (Sec. 5.6).
4. Defrost thermostat defective (Sec. 5.8).

Blower does not run with fan switch in either position.

Compressor runs briefly but cycles on & off.

1. Loose connection in blower circuit (see Fig. 2).
2. Obstruction prevents impeller rotation.
3. Defective blower (Sec. 5.5).
4. Blower switch defective.

Evaporator coil frosted continuously, low dehumidifying capacity.

1. Defrost thermostat loose or defective (Sec. 5.8).
2. Low refrigerant charge.
3. Dirty air filter or air flow restricted (Sec. 4.1B).

5.4 Refrigerant Charging

If the refrigerant charge is lost due to service or a leak, a new charge must be accurately weighed in. If any of the old charge is left in the system, it must be removed before weighing in the new charge. Follow EPA recovery regulations. Refer to the unit nameplate for the correct charge weight and refrigerant type.

5.5 Blower Replacement

The centrifugal blower has a PSC motor and internal thermal overload protection. If defective, the complete assembly must be replaced.

1. Unplug the power cord.
2. Remove the unit top.
3. If optional HEPA, 95% efficient or carbon filters are attached to the unit back, the filter(s) and their frame must be removed.
4. Remove the back cover (4 screws).
5. Remove the cabinet (6 screws).
6. Disconnect the blower leads: black from the black wire at wire nut, and white from the run capacitor.
7. Remove the foam pieces at the blower outlet at the bottom back to access the blower screws.
8. Remove the 4 screws holding the blower outlet flange and remove the blower.
9. Reassembling with the new blower is the above procedure reversed.

5.6 Compressor/Capacitor Replacement

⚠ CAUTION! **ELECTRIC SHOCK HAZARD:** Electrical power must be present to perform some tests; these test should be performed by a qualified service person.

This compressor run capacitor is accessed by following steps 1 through 4 in section 5.5 on blower replacement; the compressor is accessed by following steps 1 through 5. This compressor is equipped with a two terminal external overload, run capacitor, but no start capacitor or relay (see Fig. 2).

Perform the following tests if the blower runs but the compressor does not with the **AUTO FAN** and the humidity control **ON**.

1. Unplug the unit, follow steps 1 through 5 of section 5.5 to access the compressor. Remove the electrical connection cover on the compressor top.

2. Plug in the unit and turn the humidity control to **ON**. If the compressor tries to start but cycles on the over load, go to step 4. If the compressor remains silent, check for 110 volts from compressor terminal R to overload terminal 3 using an AC voltmeter. If voltage is present, go to step 3. If there is no voltage, either the pump safety switch, defrost thermostat, low pressure control, or relay are open or there is a loose connection in the continuity; see the appropriate section if a defect is suspected.
3. Check continuity between overload terminals 1 and 3: if there is none, the overload may be tripped. Wait 10 minutes and try again. If there is still no continuity, it is defective and must be replaced.
4. Unplug the unit, then replace the run capacitor with one of the same microfarad rating and equal or greater voltage rating. If such a capacitor is unavailable, a hard start kit sized for this compressor may be used. If the compressor does not start and run correctly, the compressor is defective and must be replaced.

5.6A Replacing a Burned out Compressor

The refrigerant and oil mixture in a compressor is chemically very stable under normal operating conditions. However, when an electrical short occurs in the compressor motor, the resulting high temperature arc causes a portion of the refrigerant oil mixture to break down into carbonaceous sludge, a very corrosive acid and water. These contaminants must be carefully removed otherwise even small residues will attack replacement compressor motors and cause failures.

Test the failed compressor oil with a test kit. If it indicates a burn-out, follow EPA regulations for disposing of the old refrigerant and oil. Follow standard procedures for replacing a burned-out compressor. These would include replacement of the liquid line filter/drier and addition of an oversized suction line filter/drier if it was a running burn-out. Several changes of the liquid and suction filter/driers may be necessary to cleanse the system.

5.6B Replacing a Compressor-Nonburn Out

Dispose of the old refrigerant per EPA guidelines. Replace the compressor and liquid line filter/drier. Weigh in the refrigerant quantity listed on the nameplate.

5.7 Humidity Control

The humidity control is an adjustable switch that closes when the relative humidity of the air in which it is located rises to the dial set point. It opens when the RH drops 4 to 6% below the set point.

5.8 Defrost Thermostat

The defrost thermostat is attached to the refrigerant suction tube between the accumulator and compressor. It will automatically shut the compressor off if the low side refrigerant temperature drops due to excessive frost formation on the evaporator coil. The blower will continue to run, causing air to flow through the evaporator coil and melt the ice. When the ice has melted, the evaporator temperature will rise and the thermostat will restart the compressor.

5.9 Condensate Pump

Condensate is automatically pumped to a remote location when the water level in the pump's reservoir rises to close the float switch.

The pump also contains a safety float switch. If the pump fails, this switch opens the compressor control circuit and stops water production before the reservoir overflows. The compressor will stop, but the blower will not.

5.10 Relay

The relay provides power to the compressor via the black wire. Current passes through relay contacts between terminals 4 and 6. The contacts are closed when power is applied to relay terminals 0 and 1 by the dehumidistat, pump safety, defrost control and low pressure control are all closed.

If there is no continuity between terminals 4 and 6 when power is applied to terminal 0 and 1 by the control circuit, the relay is defective and must be replaced. The relay is also defective if there is continuity between 4 and 6 when no power is applied to 0 and 1.

5.11 Low Pressure Control

If the low side refrigerant pressure drops to 15 PSIG, the low pressure control opens; this opens the blower circuit and the control circuit that controls the compressor. It is an automatically reset control; it will close if the pressure rises to 37 PSIG. Its primary function is to prevent damage to the compressor if a leak develops in the refrigeration system.

SANTA FE Rx WIRING DIAGRAM

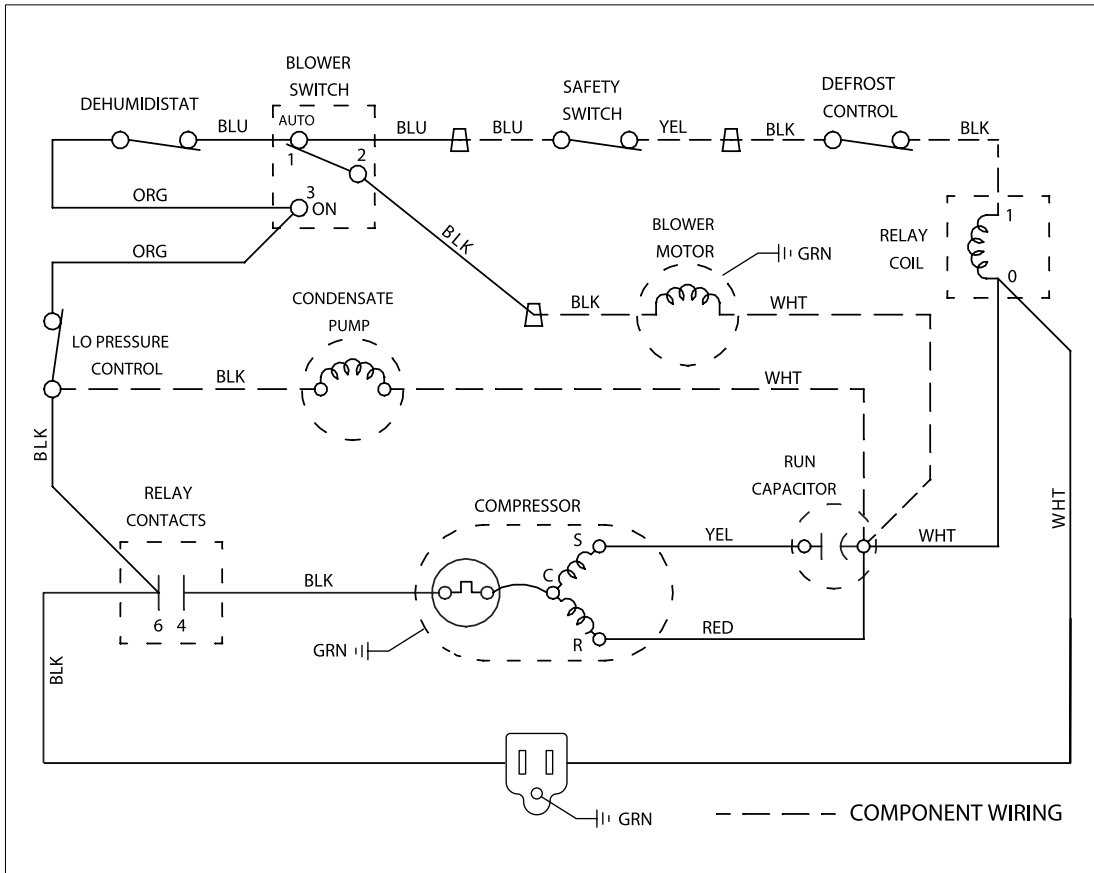

 Therma-Stor[®] LLC Made in U.S.A. Therma-Stor LLC, Madison, WI 53708 • 800-533-7533 www.thermastor.com	PART NO.	REV.
	4023857	C

SANTA FE Rx SERVICE PARTS LIST • To order contact your reseller or call 1-800-533-7533

ITEM	PART NO.	QTY.	DESCRIPTION
1	4022254	1	Accumulator
2	4021475	1	Air Filter, 2 x 16 x 20 Nominal
	4024145	1	Air Filter, 4 x 20 x 32 Nominal, HEPA (optional, requires kit, Item 3)
	4022164	2	Air Filter, 4 x 16 x 20 Nominal, 95% (optional, requires kit, Item 3)
3	4023869	1	Air Filter Frame Kit (optional)(not shown)
4	4026930	1	Blower, with Capacitor 350CFM, 115V
5	4023871	1	Top Catch & Strike Set (not shown)
6	4024912	1	Capacitor, Run, 25 Mfd
7	4021589	2	Capillary Tube, .050 I.D. X .144 O.D. X 28" Long
8	4023604	4	Caster, Swivel, 2"
9	4021396	1	Condenser Coil
10	4026703	1	Compressor

ITEM	PART NO.	QTY.	DESCRIPTION
11	4023649	1	Condensate Pump, Low Profile
12	4023661	1	Cord/Wire Harness (not shown)
13	4021470	1	Defrost Control Thermostat
14	4021648	1	Defrost Thermostat Mounting Clip
15	4021395	1	Evaporator Coil
16	4025087	1	Filter, Drier
17	4023747	1	Hose, Vinyl, .19 ID x20'
18	4021469	1	Humidity Controller
19	4021495	1	Knob, .25 Shaft
20	4023857	1	Label, Wiring Diagram (not shown)
21	4023868	1	Metal Top (not shown)
22	4022219	1	Low Pressure Control
23	1970010	1	Relay, 25A
24	4025560	1	Rocker Switch For Fan

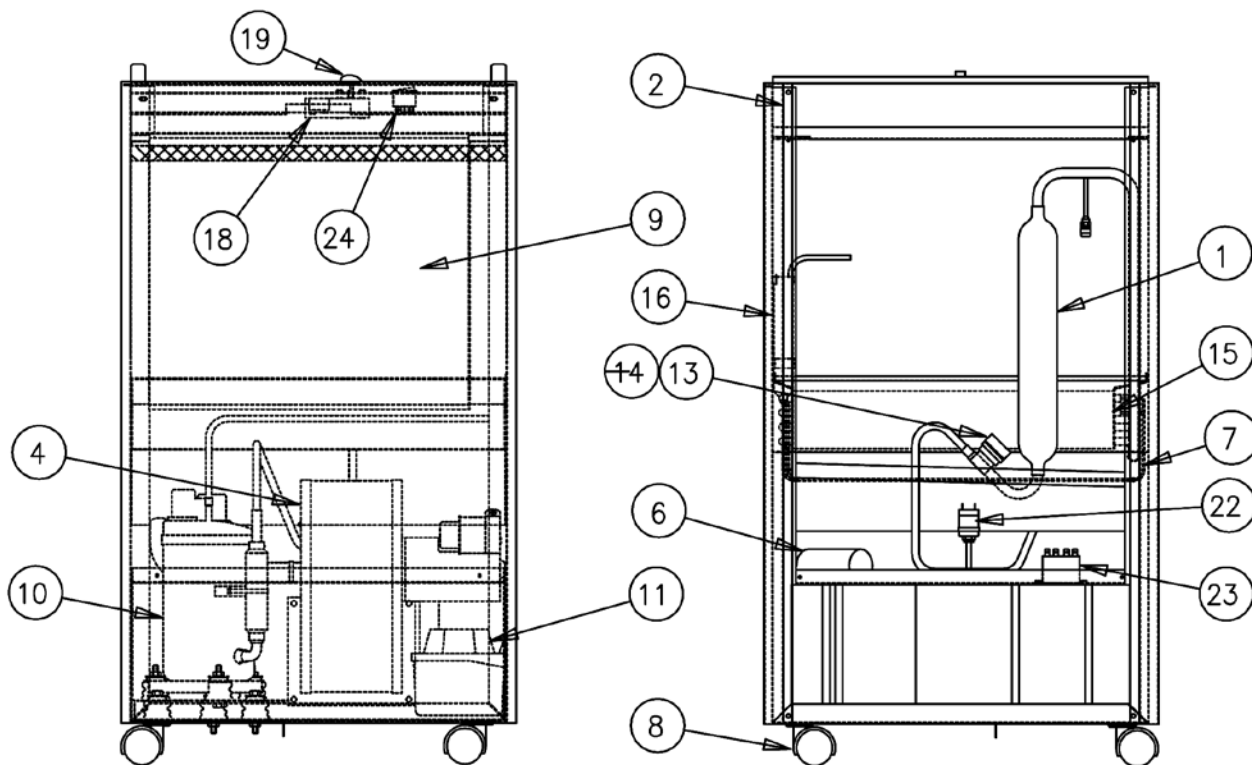

Figure 3

SANTA FE Rx FILTER FRAME ASSEMBLY

This kit attaches to the back of the Santa Fe Rx. The back is the side where the air comes out of the lower section.

1. Remove the protective plastic from the frame top & sides. Assemble the frame top (Item 1) & bottom (Item 2) to the frame sides (Items 3) with (8) screws (Item 6). The frame bottom has 3/4" thick by 1" wide foam on one outer edge. The frame top has 1/2" thick by 1/2" wide foam on the equivalent edge.

2. Push the plastic nuts into the (6) square holes on the unit back. If they are difficult to push in, gently tap them in with a hammer or rubber mallet.

NOTE: The service panel on the back of the unit (26 1/4" high x 18 1/2" wide, held with 6 screws) must remain in place when using this filter frame assembly. DO NOT REMOVE.

3. Place a rug or cardboard down and lay the Santa Fe Rx on its front. Screw the frame to the Santa Fe Rx back with (6) screws (Item 6) into the plastic nuts starting with the middle screws. Stand unit upright.

4. Remove the (4) screws that attach the frame top to the frame sides.

5. Attach the "C" shaped filter guides (Items 4) to the inside of the frame sides with machine screws and lock nuts (Items 5 & 7). Place the nuts to the inside.

6. Slide the air filter(s) into the filter guides from the top.

7. Reattach the top.

8. Reposition the Santa Fe Rx with the back of the unit at least 1.5" from a wall with the optional filter frame. Without the filter frame, at least 3" is required.

Filter Test

The optional 95% efficiency and HEPA filters have long lives when prefiltered by the standard pleated inlet filter; they can last many years in certain conditions. How long they last can, however, vary widely depending upon the following: Unit run time, air contamination level, and standard inlet filter cleanliness. Due to the optional filters' expense, it can be costly to change them prematurely. The following test helps determine when they should be changed.

Air exiting the bottom rear of the unit enters the filter frame, then passes through the optional filter and into the room. If the filter is dirty, air pressure builds up before the filter. To check this pressure, remove the plastic plug from the filter frame top; you will feel air coming out of the hole with the unit running. Place the ping pong ball that came with the filter frame on the hole and let go (any marked, regulation sized ping pong ball will work). If the ball does not move or only bounces slightly and does not spin continuously, the filter is clean enough for continued use. If the ball floats above the hole and starts to spin and perhaps wobble within 30 seconds, the filter needs to be changed.

Parts List

ITEM NO.	PART NO.	QUANTITY	DESCRIPTION
1.	4023947	1	Frame Top
2.	4023948	1	Frame Bottom
3.	4023946	2	Frame Side
4.	4023606	2	Filter Guide ("C" shaped)
5.	1096181	4	Machine Screw, #8-32 x 1/2" long
6.	1027265	16	Thread Forming Screw, #8-18 x 1/2" long (1 spare)
7.	1280378	4	Lock Nut, #8-32
8.	4024105	1	Ping Pong Ball (used for Filter Test: Save)

SANTA FE Rx SET UP INSTRUCTIONS

Before operating this unit, please read the Installers & Owners Manual.

How to prepare the Santa Fe Rx for operation

1. Locate the unit per the manual.
2. Cut the cable tie holding the cord and hose on top.
3. Route the hose to a drain (see manual).
4. Dehumidistat is preset at the factory. See manual for adjustment instructions.
5. Blower switch is set in the off position at the factory. See manual for blower operation options.
6. Install the filter (as shown in Figure). Air flow arrow must point down.
7. Lower the top down so the keyhole slots in the top drop over the posts. Slide the top until the catch latches to the strike (as shown in Figure).

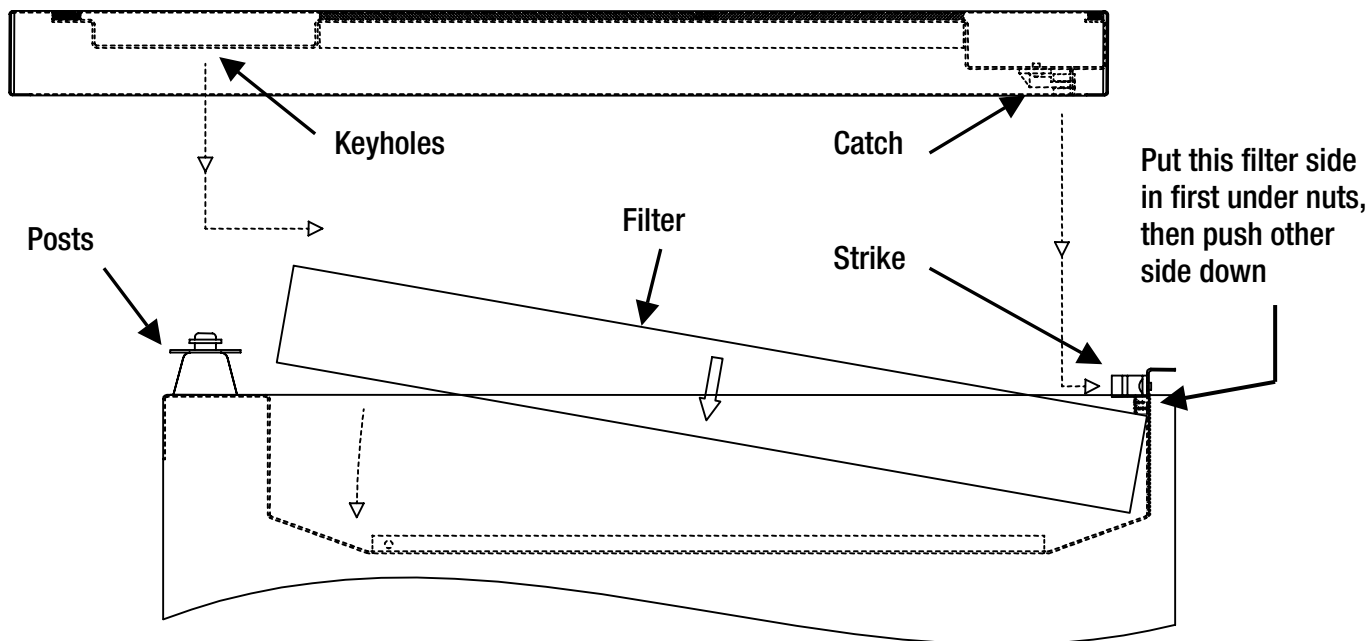



Limited Warranty

Limited Warranty. Therma-Stor, LLC (“Therma-Stor”) warrants as follows: (i) the Santa Fe Rx dehumidifier (“Product”) will be free of material defects in workmanship or materials for a period of one (1) year (“One-Year Warranty”) following the date of initial purchase of such Product by an original customer purchasing from Therma-Stor or an authorized reseller (“Customer”); and (ii) the Product’s condenser, evaporator, and compressor will be free of material defects in workmanship or materials for a period of five (5) years following the date of initial purchase of such Product by a Customer.

Limitation of Remedies. CUSTOMER’S SOLE AND EXCLUSIVE REMEDY UNDER THE ABOVE LIMITED WARRANTY AND THERMA-STOR’S ENTIRE LIABILITY THEREUNDER, SHALL BE, AT THE SOLE OPTION OF THERMA-STOR, REPLACEMENT OR REPAIR OF SUCH PRODUCT OR ITS COMPONENTS (“COMPONENTS”) BY THERMA-STOR OR THERMA-STOR’S AGENTS ONLY. REFRIGERANT, PIPING, SUPPLIES, TRANSPORTATION COSTS, LABOR COSTS INCURRED IN REPAIR OR REPLACEMENT OF SUCH COMPONENTS ARE NOT INCLUDED. THIS DISCLAIMER AND EXCLUSION SHALL APPLY EVEN IF THE EXPRESS WARRANTY AND LIMITED REMEDY SET FORTH HEREIN FAILS OF ITS ESSENTIAL PURPOSE. CUSTOMER ACKNOWLEDGES THAT NO REPRESENTATIVE OF THERMA-STOR OR OF ITS AFFILIATES OR RESELLERS IS AUTHORIZED TO MAKE ANY REPRESENTATION OR WARRANTY ON BEHALF OF THERMA-STOR OR ANY OF ITS AFFILIATES OR RESELLERS THAT IS NOT IN THIS AGREEMENT. Notwithstanding the above, during the term of the One-Year Warranty only, Therma-Stor will provide, free of charge to Customer, all Components and labor (except costs related to removal and installation of Product) required to fulfill its obligations under such One-Year Warranty.

Disclaimer of Warranties. EXCEPT FOR ABOVE LIMITED WARRANTY, WHICH IS THE SOLE AND EXCLUSIVE WARRANTY PROVIDED WITH RESPECT TO THE PRODUCT AND ITS COMPONENTS, THERMA-STOR HEREBY DISCLAIMS ALL EXPRESS AND IMPLIED WARRANTIES, INCLUDING, WITHOUT LIMITATION, THE IMPLIED WARRANTIES OF MERCHANTABILITY AND FITNESS FOR A PARTICULAR PURPOSE.

Warranty Limitations. The foregoing limited warranty extends only to a Customer and shall be null and void upon attempted assignment or transfer. A “defect” under the terms of the limited warranty shall not include problems resulting from Customer’s or Customer’s employees’, agents’, invitees’ or a third party’s misuse, improper installation, improper design of any system in which the Product is included, abuse, lack of normal care, failure to follow written instructions, tampering, improper repair, or freezing, corrosion, acts of nature or other causes not arising out of defects in Therma-Stor’s workmanship or material. If a Product or Component is replaced while under warranty, the applicable limited warranty period shall not be extended beyond the original warranty time period. The limited warranty does not cover any costs related to changes to a Product or Component that may be required by any codes, laws, or regulations that may become effective after initial purchase of the Product by Customer.

Customer Responsibilities. As a further condition to obtaining warranty coverage hereunder, the Customer must send a valid warranty claim to Therma-Stor such that Therma-Stor receives such claim prior to the end of the applicable warranty period. Therma-Stor shall have no obligation hereunder with respect to any claim received by Therma-Stor after the expiration of the applicable warranty period. As a further condition to obtaining warranty coverage hereunder, the Customer must present forms of invoices evidencing proof of purchase of a Product. If such invoices do not clearly indicate the date of initial purchase by a Customer, the applicable Product’s date of manufacture will be used instead of the date of initial purchase for the purpose of calculating the commencement of the applicable warranty period. Warranty service must be performed by Therma-Stor or a servicer authorized by Therma-Stor. In order to obtain warranty service, the Customer should call Therma-Stor at 1-800-533-7533 and ask for the Therma-Stor Products Service Department, which will then arrange for applicable warranty service. Warranty service will be performed during customary, daytime working hours. If the Product must be shipped for service, Customer shall be solely responsible for properly packaging the Product, for all freight charges, and for all risk of loss associated with shipment.

Limitation of Liability. IN NO EVENT SHALL THERMA-STOR, IN CONNECTION WITH THE DESIGN, SALE, INSTALLATION, USE, REPAIR, REPLACEMENT OR PERFORMANCE OF ANY PRODUCT, COMPONENT, PART THEREOF OR WRITTEN MATERIAL PROVIDED THEREWITH, BE LIABLE, TO THE EXTENT ALLOWED UNDER APPLICABLE LAW, UNDER ANY LEGAL THEORY FOR ANY SPECIAL, DIRECT, INDIRECT, COLLATERAL OR CONSEQUENTIAL DAMAGES OF ANY KIND. NOTWITHSTANDING THE ABOVE LIMITATIONS AND WARRANTIES, THE SOLE AND EXCLUSIVE LIABILITY OF THERMA-STOR, REGARDLESS OF THE NATURE OR THEORY OF THE CLAIM, SHALL UNDER NO CIRCUMSTANCES EXCEED THE PURCHASE PRICE OF THE PRODUCT, COMPONENT OR PART UPON WHICH THE CLAIM IS PREMISED.

Applicable Law and Venue. ANY ARBITRATION, ENFORCEMENT OF AN ARBITRATION OR LITIGATION RELATED TO THE PRODUCT WILL BE BROUGHT EXCLUSIVELY IN DANE COUNTY, WISCONSIN, AND CUSTOMER CONSENTS TO THE JURISDICTION OF THE FEDERAL AND STATE COURTS LOCATED THEREIN, SUBMITS TO THE JURISDICTION THEREOF AND WAIVES THE RIGHT TO CHANGE VENUE. CUSTOMER FURTHER CONSENTS TO THE EXERCISE OF PERSONAL JURISDICTION BY ANY SUCH COURT WITH RESPECT TO ANY SUCH PROCEEDING.

Miscellaneous. If any term or condition of this Limited Warranty is found by a court of competent jurisdiction to be invalid, illegal or otherwise unenforceable, the same shall not affect the other terms or conditions hereof or thereof or the whole of this Limited Warranty. Any delay or failure by Therma-Stor to exercise any right or remedy will not constitute a waiver of Therma-Stor to thereafter enforce such rights.



Therma-Stor LLC

PO Box 8680 • Madison, WI 53708

Phone: 608-222-5301 • Fax: 608-222-1447

Web: www.thermastor.com • Email: sales@thermastor.com

Information in this document is subject to change without notice. No part of this document may be reproduced or transmitted in any form or by any means, electronic or mechanical, for any purpose, without the express written permission of Therma-Stor LLC. © 2008 Therma-Stor LLC. All rights reserved.
