

STM150 & TSR150

Application

- Steamer Equipment

ScaleGard® Plus 2 Reverse Osmosis Systems

Spec No. _____

Quantity _____



STM150

Product Features

- ◆ Compact design utilizes quick disconnect fittings, stainless steel bracket, and optional wall mounting.
- ◆ Provides easy adaptation to existing piping, resistance to rust and corrosion, and easy access to tight areas.
- ◆ SQC™ - Sanitary Quick Change encapsulated design reduces contamination during change-outs and are disposable and incineratable.
- ◆ 220V/50Hz and 100V/50Hz are available for international electrical requirements.
- ◆ FDA CFR-21 and/or NSF compliant materials provides peace of mind that this product is suitable for potable applications.
- ◆ Includes a built-in bypass solenoid with convenient 3/8" NPT connections.

The STM150 and TSR150 Reverse Osmosis water filtration systems are uniquely designed to produce consistent quality water for the specific reduction of scale causing minerals in boiler based steamer applications. The STM150/TSR150 RO membrane is designed to reject over 96% of minerals that cause scale build-up and equipment problems. Activated carbon and graded density pretreatment protect the RO membrane. The post-treatment filters adjust the product water to allow electronic probes to function correctly in water conditions up to 2,000 ppm TDS.

Product Specifications

Model Number	Part Number	Voltage Requirements	Capacity	Performance	Application
STM150	STM150	110V/60Hz	150 gpd (568 lpd) 6.25 gph (23.7 lph)	For moderate TDS conditions	For incoming water conditions under 500 ppm TDS
TSR150	TSR150	110V/60Hz	150 gpd (568 lpd) 6.25 gph (23.7 lph)	For high TDS conditions	For incoming water conditions over 500 ppm TDS

STM150-A @ 220V/50Hz

TSR150-2B @ 100V/50Hz with 20/40 pressure switch

STM150-B @ 100V/50Hz

TSR150-4A @ 220V/50Hz with 40/70 pressure switch

TSR150-2A @ 220V/50Hz with 20/40 pressure switch

TSR150-4B @ 100V/50Hz with 40/70 pressure switch



Water Filter Systems

Foodservice

STM150 & TSR150 ScaleGard® Plus 2 Reverse Osmosis Systems

Spec No. _____
 Quantity _____
 Model Number _____
 Part Number _____

Physical Specifications:

- System to incorporate reverse osmosis technology.
- System to be sanitary in design, requiring no contact with the media during filter change-out.
- System to contain integrated pre- and post- filtration for the reduction of sediment; chlorine taste and odor; and TDS.
- Membrane to provide better than 96% rejection of TDS.
- System to operate with an integrated booster pump.
- System to contain an integrated automatic bypass.
- System to be manufactured from FDA CFR-21 and/or NSF compliant materials.
- System to be wall-mountable with stainless steel bracket design.
- System inlet and outlet plumbing connections to be 3/8" quick disconnect.
- System to have maximum line pressure of 65 psi (448 kPa) and operating temperature of 100°F (38°C).

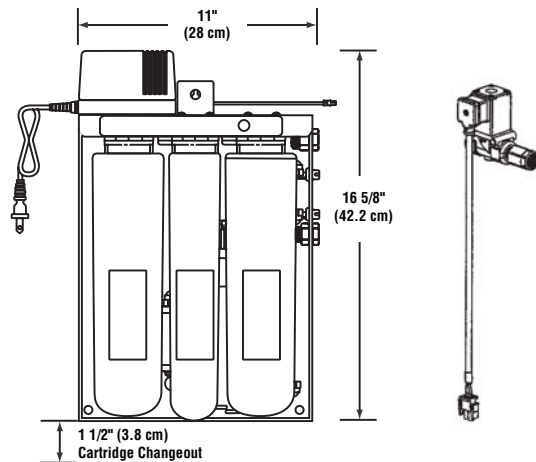

Installation Tips:

- Shut off downstream equipment prior to installation of the system.
- Do not exceed operating parameters for temperature or pressure.
- Do not install outdoors.
- For cold water use only.
- For commercial use only.

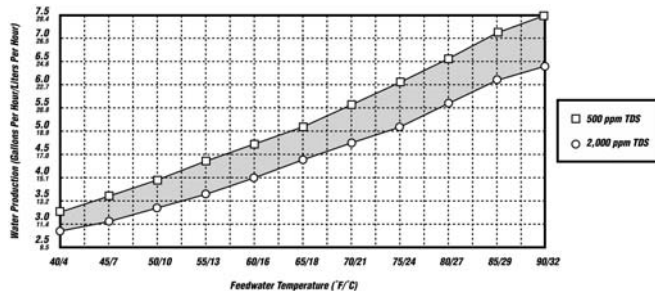

Do not use with water that is microbiologically unsafe or of unknown quality without adequate disinfection before or after the system. Systems certified for cyst reduction may be used on disinfected water that may contain filterable cysts.

CUNO Incorporated recommends regularly scheduled maintenance and replacement of the filter cartridge(s) in order for the product to perform as advertised/sold.

Sizing Guide

Steamer Size	Electric Steamers				Gas Steamers		
	3Kw	5Kw	8Kw	9Kw	12Kw	25,000 BTU	50,000 BTU
Gallons (Liters) Req'd per Hour	1.2 (4.5)	2 (7.6)	3.2 (12.1)	3.6 (13.6)	4.8 (18.2)	2 (7.5)	3.6 (13.6)
Recommended Unit	STM150 TSR150	STM150 TSR150	STM150 TSR150	STM150 TSR150	STM150 TSR150	STM150 TSR150	STM150 TSR150
Recommended Tank	5 gal.	5 gal.	10 gal.	10 gal.	10 gal.	5 gal.	10 gal.

Storage Tank Options

Part Number	Capacity at 60 psi (414 kPa)
55984-05	2.5 gallon (9.5 liter) drawdown
55984-06	5 gallon (18.9 liter) drawdown
55984-07	10 gallon (37.9 liter) drawdown
55984-08	20 gallon (75.7 liter) drawdown
55984-09	40 gallon (151.4 liter) drawdown

Replacement Cartridges

Model Number	Part Number	Type	Used In	Qty Required
S	55997-01	Sediment Reduction	STM/TSR	1
C	55995-01	Chlorine Taste and Odor Reduction	STM/TSR	1
T	55998-01	TDS Adjustment Filter for STM Units	STM	1
M	55987-07	RO Membrane	STM/TSR	1
H	55996-01	Hardness Reduction for TSR Units	TSR	1

Limited 5 Year Warranty

CUNO Incorporated warrants to the original purchaser-consumer that this product is free from defects in materials and workmanship. This warranty, together with any and all warranties implied by law, shall be limited to a period of five (5) years from the date of original purchase by the consumer. This warranty does not apply to failures that result from abuse, misuse, alteration or damage not caused by CUNO. This warranty is subject to exclusions and limitations. 5 Year Warranty excludes pumps, motors and transformers. Please refer to the Warranty Card provided with the product for details.

Service Worldwide

China
 CUNO Filtration Shanghai Co. Ltd.
 No. 2 Plant East Side
 Xin Miao San Road
 XinQiao Town SongJiang District
 Shanghai, China 201612

Australia
 CUNO Pacific Pty Ltd.
 140 Sunnyholt Road
 Blacktown, N.S.W. 2148
 Australia

Europe
 CUNO Limited
 21 Woking Business Park
 Albert Drive
 Woking, Surrey
 GU21 5JY, England



Japan
 CUNO K.K.
 Hodogaya Station Building 6F
 1-7, Iwai-Cho, Hodogaya-Ku
 Yokohama 240-0023, Japan

Brazil
 CUNO Latina Ltda
 Rua AMF do Brazil - 251
 18120 Mairinque-SP, Brazil

Singapore
 CUNO Filtration Asia Pte Ltd
 18 Tuas Link 1
 3rd Floor
 Singapore 638599

CUNO Incorporated
 400 Research Parkway
 Meriden, CT 06450, USA
 Toll Free: 1-888-218-CUNO
 Worldwide: 203-237-5541
 Fax: 203-238-8701