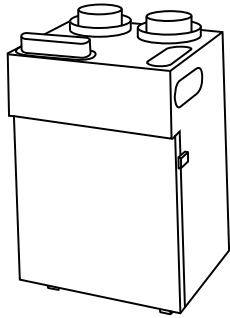


# AMERICAN aldes

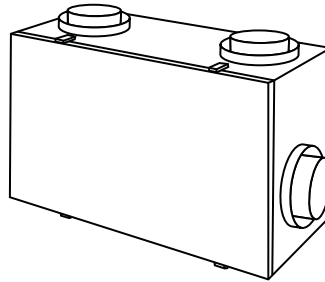
VENTILATION CORPORATION

## Operation and Installation Manual

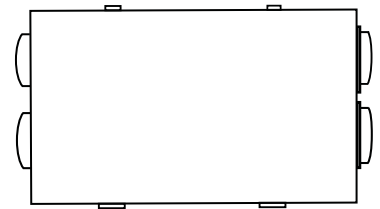
# Premium Series



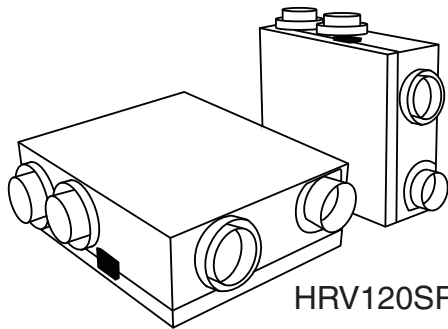
HRV95SRD



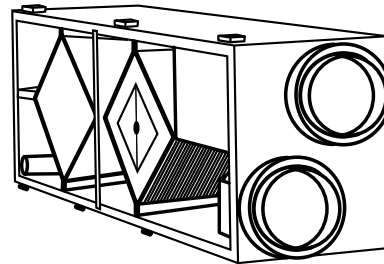
HRV155SRD  
HRV200SRD



ERV200S



HRV120SRD



HRV300DDD

### LEAVE FOR HOMEOWNER

TO BE COMPLETED BY CONTRACTOR AFTER INSTALLATION

Installing Contractor \_\_\_\_\_ Telephone / Contact \_\_\_\_\_

Serial Number \_\_\_\_\_ Installation Date \_\_\_\_\_

Model \_\_\_\_\_

#### New Auto Dehumidistat Function

prevents unwanted use of the dehumidistat when outdoor temperatures exceed 15°C (59°F).

**INSTALLER: Leave this manual for the homeowner**

Installation and wiring to be in accordance with CEC, NEC and local electrical codes.

Important: Read and save these instructions.



## Table of Contents

|  |       |
|--|-------|
| Warranty.....  | 2     |
| Technical Data - Model HRV95SRD .....  | 3     |
| Port Configuration and Airflow - Model HRV95SRD .....  | 4     |
| Technical Data - Model HRV120SRD .....   | 5     |
| Technical Data - Model HRV155SRD .....   | 6     |
| Technical Data - Model HRV200SRD .....   | 7     |
| Technical Data - Model HRV300DDD .....   | 8     |
| Technical Data - Model ERV200S .....   | 9     |
| Controlling your HRV/ERV<br>How the Dehumidistat Works                                       |       |
| Glossary.....  | 10    |
| The Premium Series Digital Control Model ADXC-II.....  | 11    |
| The Premium Series Programmable Control Model APV.....                                       | 12    |
| Optional Timers<br>The DH-II Dehumidistat .....  | 13    |
| Installation Methods.....  | 14    |
| Installation Diagrams .....  | 15-17 |
| Installation.....  | 18    |
| Engineering Data HRV .....   | 19    |
| Suspending the HRV120SRD .....   | 20    |
| Drain Connection<br>Grilles .....  | 21    |
| Weatherhood Installation .....   | 22    |
| Installation of the Main Control.....  | 23    |
| Installation and Operation 20/40/60/ Minute Timers<br>Installation of Mechanical Timers..... | 24    |
| Installation of ZRT Zone Register Terminal.....  | 25    |
| Interlocking HRV/ERV to an Airhandler/Furnace Blower<br>Dry Contacts.....                    | 26    |
| Pitot Tube Air Flow Balancing .....  | 27    |
| Air Flow Measuring Kit .....   | 28    |
| Balancing Collar Instructions.....   | 29    |
| Maintenance Routine for your HRV/ERV .....   | 30    |
| Troubleshooting your HRV/ERV System.....   | 31    |
| Wiring Diagrams.....   | 32-33 |
| Heat and Energy Recovery Ventilator Warranty .....   | 34    |

**IMPORTANT -  
PLEASE READ THIS MANUAL  
BEFORE INSTALLING UNIT.**

### NOTE

**Due to ongoing research and product development, specifications, ratings and dimensions are subject to change without notice.**

## CAUTION

**Before installation, careful consideration must be given to how this system will operate if connected to any other piece of mechanical equipment, i.e. a forced air furnace or air handler, operating at a higher static. After installation, the compatibility of the two pieces of equipment must be confirmed, by measuring the air flows of the HRV/ERV, by using the balancing procedure found in this manual. NEVER install a ventilator in a situation where its normal operation, lack of operation or partial failure may result in the backdrafting or improper functioning of vented combustion equipment.**

**Do Not Connect the HRV/ERV supply air duct to the supply or return duct of an air conditioner, in climate zones where the outdoor air dew point often exceeds 55°F (13°C) (that is, in warm, humid climates). Failure to observe this may result in condensation of moisture inside the ducting. It is not recommended to operate the HVAC fan continuously in such climates.**

## Warranty

All Heat Recovery Ventilators carry a fifteen (15) year warranty on the heat recovery core and a 2 (two) year replacement parts warranty.

All Energy Recovery Ventilators carry a 5 (five) year warranty on the energy recovery core and a 2 (two) year replacement parts warranty.

During the warranty period, if any core experiences a failure or perforation caused by normal use while owned by the original purchaser, a replacement core (FOB our plant) will be supplied at no expense.

**ENGINEERING DATA**

**THERMALLY CONDUCTIVE, PATENTED ALUMINUM CORE**

The cross-flow heat recovery core transfers heat between the two airstreams. It is easily removed for cleaning or service.

**MOTORS AND BLOWERS**

Each air stream has one centrifugal blower driven by a common PSC motor. 5 speed fan operation.

**FILTERS**

Washable air filters in exhaust and supply air streams.

**MOUNTING THE HRV**

Four threaded inserts at corners of the cabinet designed to accept PVC reinforced polyester straps that are supplied with the unit.

**DEFROST**

Recirculating defrost system.

**CASE**

Twenty gauge prepainted galvanized steel (G60) for superior corrosion resistance. Insulated to prevent exterior condensation. Drain connections 2 - 1/2" (12 mm) OD.

**WEIGHT** 52 lbs. (23.6 kg) **SHIPPING WEIGHT** 56 lbs. (25.4 kg)

**PREMIUM SERIES ELECTRONICS**

- Built-in Relay for Interfacing to furnace
- Built-in Dehumidistat disable feature

**CONTROLS & ELECTRONICS**

The **Premium Series Digital Control** (Model ADXC-II) is included with unit and can be wall mounted in a central location of the home.

- 2 Speed Operation on each mode
- 4 user selectable operational modes: Continuous Ventilation, 20 ON/40 OFF, 20 ON/40 Recirculation, Continuous Recirculation
- Adjustable Dehumidistat function built into the main wall control
- Connected to 3 wire 20 gauge low voltage wire

**OPTIONAL PROGRAMMABLE CONTROL**

**Premium Series Digital Control** (Model APVC) - contains all the features of the Premium Series Digital Control with 5 speeds and 7/24 programmable ventilation, (3 wire) min 20 gauge wire max 100' length

**OPTIONAL TIMERS**

**DET-II 20/40/60 Minute Timer** - Initiates high speed ventilation for 20, 40, or 60 minutes, (3 wire) min 20 gauge wire max 100' length

**28998 Mechanical Timer** - Initiates High speed ventilation for up to 60 minutes, (2 wire) min 20 gauge wire max 100' length

**OPTIONAL ACCESSORIES**

**DH-II Dehumidistat** - Initiates high speed ventilation when the indoor humidity level is above the set point. (3 wire) min 20 gauge wire max 100' length

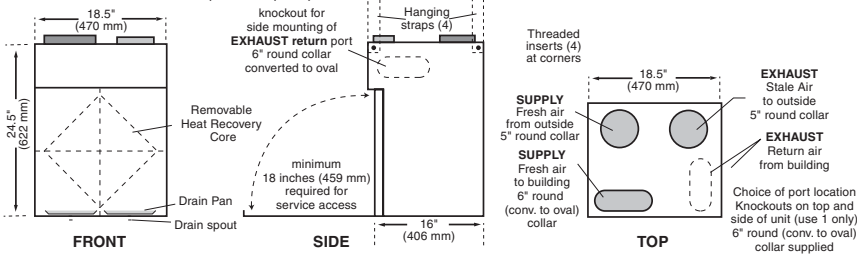
**22025 Weatherhoods**, Two - 5" (125 mm) c/w 1/4" (6 mm) mesh screen

**ZRT-1 Zone Register Terminal** permits intermittent ventilation control at any exhaust terminal, controlled by local timer switch, simultaneously turns HRV/ERV on high speed. Suggested use: bathrooms and shower areas.

**ZRT-2 Zone Register Terminal** permits constant low airflow with boost exhaust, controlled by local timer switch, simultaneously turns HRV/ERV on high speed. Suggested use: bathroom and shower areas.

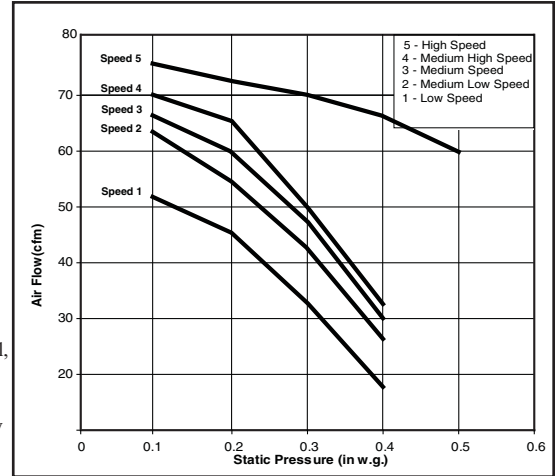
**Constant Exhaust Registers:** Airflows remain constant while other zones are turned on and HRV/ERV runs at high speed. Suggested use: laundry areas and pet rooms.

**DIMENSIONS HRV95SRD (inches (mm))**



| <b>Performance</b> (HVI certified)<br><i>Net supply air flow in cfm (L/s) against external static pressure</i> |                    |     |
|--|--------------------|-----|
| <b>E.S.P</b><br><b>(external static pressure)</b>  | <b>[cfm (L/s)]</b> |     |
| @ 0.1" (25 Pa)   | 76 (36)            |     |
| @ 0.2" (50 Pa)   | 73 (34)            |     |
| @ 0.3" (75 Pa)   | 70 (33)            |     |
| @ 0.4" (100 Pa)  | 66 (31)            |     |
| @ 0.5" (125 Pa)  | 60 (29)            |     |
| Max. Temperature Recovery  | 88%                |     |
| Sensible Effectiveness   |                    |     |
| @ 60 cfm (28 L/s)  | 32°F (0°C)         | 88% |
| *Sensible Efficiency   |                    |     |
| @ 60 cfm (28 L/s)  | 32°F (0°C)         | 75% |
| *Sensible Efficiency   |                    |     |
| @ 61 cfm (29 L/s)  | -13°F (-25°C)      | 68% |
| VAC @ 60HZ   | 120                |     |
| WATTS / Low speed.   | 59                 |     |
| WATTS / High speed   | 89                 |     |
| Amp rating   | 0.9                |     |

\*Sensible Efficiency – thermal \*\*Latent Efficiency – moisture  
Note: Effectiveness - based on temp. differential between the 2 airstreams  
Efficiency – takes into account all power inputs



All units conform to CSA and UL standards.

**WARRANTY**

Units carry a fifteen (15) year warranty on the heat recovery core and a two (2) year replacement parts warranty.

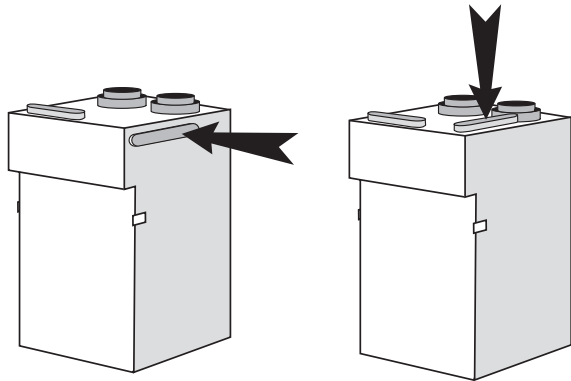
Date: \_\_\_\_\_  
Tag: \_\_\_\_\_ Qty: \_\_\_\_\_  
Project: \_\_\_\_\_  
Engineer: \_\_\_\_\_

Contractor: \_\_\_\_\_  
Supplier: \_\_\_\_\_  
Quote#: \_\_\_\_\_  
Submitted by: \_\_\_\_\_



**HRV95SRD Port Specifications**

The Heat Recovery Ventilator (HRV) has been designed to allow the installer to choose between two possible positions on the cabinet for the INDOOR EXHAUST (return from building) port. Illustrations in this manual show standard (side mounted) port location. The same specifications apply to both HRV95SRD setups, regardless of which port position is selected.



**SIDE MOUNTED PORT**  
standard location

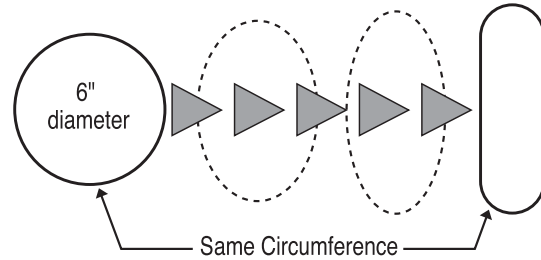
**TOP MOUNTED PORT**  
alternate location

**Variable Port Location**

**Variable Port Location / Installation  
(Model HRV95SRD only)**

The **exhaust return** port collar is not factory installed. Installer may choose either **side mounted** or alternate **top mounted** port by simply removing one of the two knock-out plates and attaching a port collar (supplied). To remove knock-out plate, insert a utility knife into the knock-out slits and trace them completely to puncture protective film underneath. Then, cut the solid tabs between the slits, using tin snips or side cutters, and remove the knock-out plate. If any protective film still blocks the opening, **remove it now**.

In order to make the HRV95SRD as space efficient as possible, the INDOOR supply and return ports are converted from round to oval shape. Overall size of the port remains the same. Simply bend a standard duct fitting to the correct shape, and attach to the oval port using the same method as for a round port.



**Round port bent to oval**

**HRV95SRD Air Flow**

Stale air enters the **FRONT RIGHT** side port. The air will pass down the front half of the core, then up the back half of the core and out the **RIGHT REAR** port.

Fresh outdoor air will enter the **LEFT REAR** port and pass down the back half of the core. It will then pass up the front half of the core, and out the **LEFT FRONT** port. This unique configuration allows the air to actually travel through the core twice, making the HRV95SRD almost as efficient as a double core unit.

### ENGINEERING DATA THERMALLY CONDUCTIVE, PATENTED ALUMINUM CORE

The cross-flow heat recovery core transfers heat between the two airstreams. It is easily removed for cleaning or service.

### MOTORS AND BLOWERS

Each air stream has an independent motorized impeller, 5 speed fan operation.

### FILTERS

Washable air filters in exhaust and supply air streams.

### MOUNTING THE HRV

Four threaded inserts at corners of case designed to accept four reinforced polyester straps that are supplied with the unit.

### DEFROST

Recirculating damper defrost system.

### CASE

Twenty gauge prepainted galvanized steel (G60) for superior corrosion resistance. Insulated to prevent exterior condensation. Drain connections 2 - 1/2" (12 mm) OD.

**WEIGHT** 42 lbs. (19 kg) **SHIPPING WEIGHT** 45 lbs. (20.5 kg)

### PREMIUM SERIES ELECTRONICS

- Built-in Relay for Interfacing to furnace
- Built-in Dehumidistat disable feature

### CONTROLS & ELECTRONICS

The **Premium Series Digital Control** (Model ADXC-II) is included with unit and can be wall mounted in a central location of the home.

- 2 Speed Operation on each mode
- 4 user selectable operational modes: Continuous Ventilation, 20 ON/40 OFF, 20 ON/40 Recirculation, Continuous Recirculation
- Adjustable Dehumidistat function built into the main wall control
- Connected to 3 wire 20 gauge low voltage wire

### OPTIONAL PROGRAMMABLE CONTROL

**Premium Series Digital Control** (Model APVC) - contains all the features of the Premium Series Digital Control with 5 speeds and 7/24 programmable ventilation, (3 wire) min 20 gauge wire max 100' length

### OPTIONAL TIMERS

**DET-II 20/40/60 Minute Timer** - Initiates high speed ventilation for 20, 40, or 60 minutes, (3 wire) min 20 gauge wire max 100' length

**28998 Mechanical Timer** - Initiates High speed ventilation for up to 60 minutes, (2 wire) min 20 gauge wire max 100' length

### OPTIONAL ACCESSORIES

**DH-II Dehumidistat** - Initiates high speed ventilation when the indoor humidity level is above the set point. (3 wire) min 20 gauge wire max 100' length

**22025 Weatherhoods**, Two - 5" (125 mm) c/w 1/4" (6 mm) mesh screen

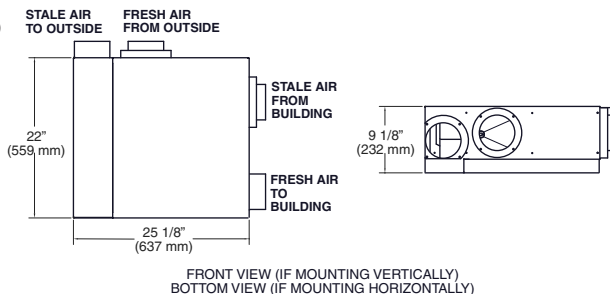
**ZRT-1 Zone Register Terminal** permits intermittent ventilation control at any exhaust terminal, controlled by local timer switch, simultaneously turns HRV/ERV on high speed. Suggested use: bathrooms and shower areas.

**ZRT-2 Zone Register Terminal** permits constant low airflow with boost exhaust, controlled by local timer switch, simultaneously turns HRV/ERV on high speed. Suggested use: bathroom and shower areas.

**Constant Exhaust Registers:** Airflows remain constant while other zones are turned on and HRV/ERV runs at high speed. Suggested use: laundry areas and pet rooms.

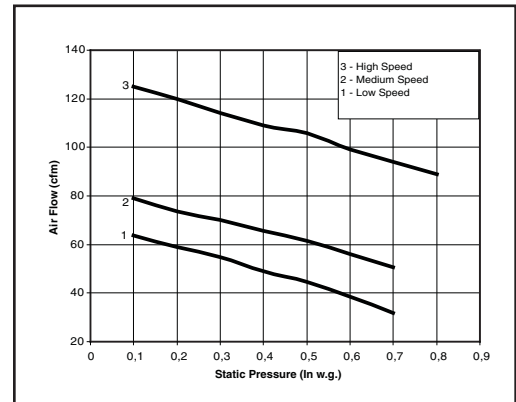
### DIMENSIONS HRV120SRD

(inches (mm))



| Performance (HVI certified)<br>Net supply air flow in cfm (L/s) against external static pressure |               |             |
|--|---------------|-------------|
| E.S.P<br>(external static pressure)  |               |             |
|  |               | [cfm (L/s)] |
| @ 0.1" (25 Pa)   |               | 150 (71)    |
| @ 0.2" (50 Pa)   |               | 146 (69)    |
| @ 0.3" (75 Pa)   |               | 134 (63)    |
| @ 0.4" (100 Pa)  |               | 121 (57)    |
| @ 0.5" (125 Pa)  |               | 106 (50)    |
| @ 0.6" (150 Pa)  |               | 92 (43)     |
| Max. Temperature Recovery  |               | 78%         |
| Sensible Effectiveness   |               |             |
| @ 65 cfm (31 L/s)  | 32°F (0°C)    | 76%         |
| *Sensible Efficiency   |               |             |
| @ 65 cfm (31 L/s)  | 32°F (0°C)    | 64%         |
| *Sensible Efficiency   |               |             |
| @ 68 cfm (32 L/s)  | -13°F (-25°C) | 66%         |
| VAC @ 60HZ   |               | 120         |
| WATTS / Low speed.   |               | 84          |
| WATTS / High speed   |               | 117         |
| Amp rating   |               | 1.4         |

\*Sensible Efficiency – thermal \*\*Latent Efficiency – moisture  
Note: Effectiveness - based on temp. differential between the 2 airstreams  
Efficiency – takes into account all power inputs



All units conform to CSA and UL standards.

### WARRANTY

Units carry a fifteen (15) year warranty on the heat recovery core and a two (2) year replacement parts warranty.

Date: \_\_\_\_\_  
Tag: \_\_\_\_\_ Qty: \_\_\_\_\_  
Project: \_\_\_\_\_  
Engineer: \_\_\_\_\_

Contractor: \_\_\_\_\_  
Supplier: \_\_\_\_\_  
Quote#: \_\_\_\_\_  
Submitted by: \_\_\_\_\_

### ENGINEERING DATA THERMALLY CONDUCTIVE, PATENTED ALUMINUM CORE

The cross-flow heat recovery core transfers heat between the two airstreams. It is easily removed for cleaning or service.

### MOTORS AND BLOWERS

Each air stream has one centrifugal blower driven by a common PSC motor. 5 speed fan operation.

### FILTERS

Washable air filters in exhaust and supply air streams.

### MOUNTING THE HRV

Four threaded inserts at corners of case designed to accept four reinforced polyester straps that are supplied with the unit.

### DEFROST

Recirculating damper defrost system.

### CASE

Twenty gauge prepainted galvanized steel (G60) for superior corrosion resistance. Insulated to prevent exterior condensation. Drain connections 2 - 1/2" (12 mm) OD.

**WEIGHT 71lbs (32.5Kg) SHIPPING WEIGHT 73lbs (33.5Kg)**

### PREMIUM SERIES ELECTRONICS

- Built-in Relay for Interfacing to furnace
- Built-in Dehumidistat disable feature

### CONTROLS & ELECTRONICS

The **Premium Series Digital Control** (Model ADXC-11) is included with unit and can be wall mounted in a central location of the home.

- 2 Speed Operation on each mode
- 4 user selectable operational modes: Continuous Ventilation, 20 ON/40 OFF, 20 ON/40 Recirculation, Continuous Recirculation
- Adjustable Dehumidistat function built into the main wall control
- Connected to 3 wire 20 gauge low voltage wire

### OPTIONAL PROGRAMMABLE CONTROL

**Premium Series Digital Control** (Model APVC-II) - contains all the features of the Premium Series Digital Control with 5 speeds and 7/24 programmable ventilation, (3 wire) min 20 gauge wire max 100' length

### OPTIONAL TIMERS

**DET-II 20/40/60 Minute Timer** - Initiates high speed ventilation for 20, 40, or 60 minutes, (3 wire) min 20 gauge wire max 100' length.

**28998 Mechanical Timer** - Initiates High speed ventilation for up to 60 minutes, (2 wire) min 20 gauge wire max 100' length.

### OPTIONAL ACCESSORIES

**DH-II Dehumidistat** - Initiates high speed ventilation when the indoor humidity level is above the set point. (3 wire) min 20 gauge wire max 100' length.

**22026 Weatherhoods**, Two - 6" (150 mm) c/w 1/4" (6 mm) mesh screen

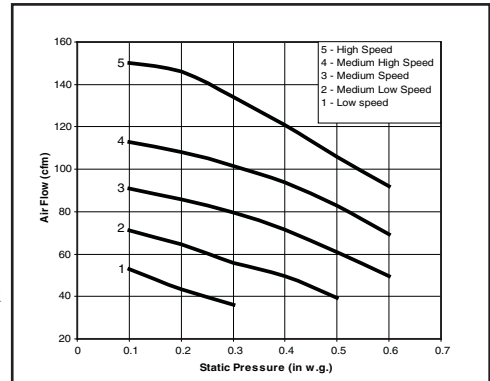
**ZRT-1 Zone Register Terminal** permits intermittent ventilation control at any exhaust terminal, controlled by local timer switch, simultaneously turns HRV/ERV on high speed. Suggested use: bathrooms and shower areas.

**ZRT-2 Zone Register Terminal** permits constant low airflow with boost exhaust, controlled by local timer switch, simultaneously turns HRV/ERV on high speed. Suggested use: bathroom and shower areas.

**Constant Exhaust Registers:** Airflows remain constant while other zones are turned on and HRV/ERV runs at high speed. Suggested use: laundry areas and pet rooms.

| Performance (HVI certified)<br>Net supply air flow in cfm (L/s) against external static pressure |               |     |
|--|---------------|-----|
| E.S.P.<br>(external static pressure)   | [cfm (L/s)]   |     |
| @ 0.1" (25 Pa)   | 150 (71)      |     |
| @ 0.2" (50 Pa)   | 146 (69)      |     |
| @ 0.3" (75 Pa)   | 134 (63)      |     |
| @ 0.4" (100 Pa)  | 121 (57)      |     |
| @ 0.5" (125 Pa)  | 106 (50)      |     |
| @ 0.6" (150 Pa)  | 92 (43)       |     |
| Max. Temperature Recovery  |               | 78% |
| Sensible Effectiveness   |               |     |
| @ 65 cfm (31 L/s)  | 32°F (0°C)    | 76% |
| *Sensible Efficiency   |               |     |
| @ 65 cfm (31 L/s)  | 32°F (0°C)    | 64% |
| *Sensible Efficiency   |               |     |
| @ 68 cfm (32 L/s)  | -13°F (-25°C) | 66% |
| VAC @ 60HZ   |               | 120 |
| WATTS / Low speed.   |               | 49  |
| WATTS / High speed   |               | 120 |
| Amp rating   |               | 1.4 |

\*Sensible Efficiency - thermal \*\*Latent Efficiency - moisture  
Note: Effectiveness - based on temp. differential between the 2 airstreams  
Efficiency - takes into account all power inputs

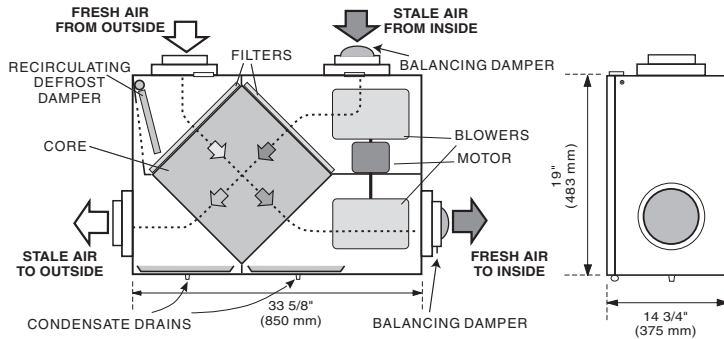


All units conform to CSA and UL standards.

### DIMENSIONS

#### HRV155SRD

inches (mm)



\*All Duct Connections 6" (150 mm)

\*NOTE: Front clearance of 25 inches (635 mm) is recommended for servicing unit.

### WARRANTY

Units carry a fifteen (15) year warranty on the heat recovery core and a two (2) year replacement parts warranty.

Date: \_\_\_\_\_  
 Tag: \_\_\_\_\_ Qty: \_\_\_\_\_  
 Project: \_\_\_\_\_  
 Engineer: \_\_\_\_\_

Contractor: \_\_\_\_\_  
 Supplier: \_\_\_\_\_  
 Quote#: \_\_\_\_\_  
 Submitted by: \_\_\_\_\_

### ENGINEERING DATA THERMALLY CONDUCTIVE, PATENTED ALUMINUM CORE

The cross-flow heat recovery core transfers heat between the two airstreams. It is easily removed for cleaning or service.

#### MOTORS AND BLOWERS

Each air stream has one centrifugal blower driven by a common PSC motor. 5 speed fan operation.

#### FILTERS

Washable air filters in exhaust and supply air streams.

#### MOUNTING THE HRV

Four threaded inserts at corners of case designed to accept four reinforced polyester straps supplied with the unit.

#### DEFROST

Recirculating damper defrost system.

#### CASE

Twenty gauge prepainted galvanized steel (G60) for superior corrosion resistance. Insulated to prevent exterior condensation. Drain connections 2 - 1/2" (12 mm) OD.

**WEIGHT 75 lbs (34 Kg) SHIPPING WEIGHT 77 lbs (38 Kg)**

#### PREMIUM SERIES ELECTRONICS

- Built-in Relay for Interfacing to furnace
- Built-in Dehumidistat disable feature

#### CONTROLS & ELECTRONICS

The **Premium Series Digital Control** (Model ADXC-11) is included with unit and can be wall mounted in a central location of the home.

- 2 Speed Operation on each mode
- 4 user selectable operational modes: Continuous Ventilation, 20 ON/40 OFF, 20 ON/40 Recirculation, Continuous Recirculation
- Adjustable Dehumidistat function built into the main wall control
- Connected to 3 wire 20 gauge low voltage wire

#### OPTIONAL PROGRAMMABLE CONTROL

**Premium Series Digital Control** (Model APVC) - contains all the features of the Premium Series Digital Control with 5 speeds 7/24 programmable ventilation, (3 wire) min 20 gauge wire max 100' length.

#### OPTIONAL TIMERS

**DET-II 20/40/60 Minute Timer** - Initiates high speed ventilation for 20, 40, or 60 minutes, (3 wire) min 20 gauge wire max 100' length.

**28998 Mechanical Timer** - Initiates High speed ventilation for up to 60 minutes, (2 wire) min 20 gauge wire max 100' length.

#### OPTIONAL ACCESSORIES

**DH-II Dehumidistat** - Initiates high speed ventilation when the indoor humidity level is above the set point. (3 wire) 20 gauge wire (min.) 100' length

**22026 Weatherhoods**, Two - 6" (150 mm) c/w 1/4" (6 mm) mesh screen

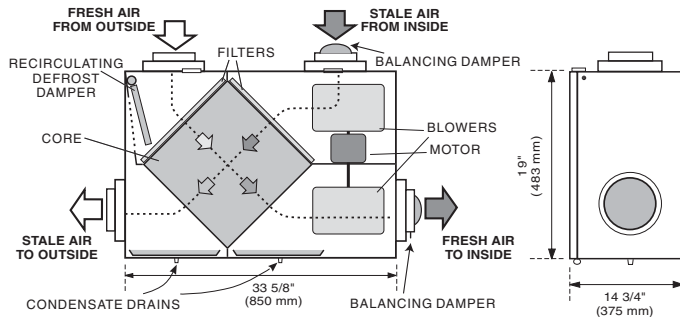
**ZRT-1 Zone Register Terminal** permits intermittent ventilation control at any exhaust terminal, controlled by local timer switch, simultaneously turns HRV/ERV on high speed. Suggested use: bathrooms and shower areas.

**ZRT-2 Zone Register Terminal** permits constant low airflow with boost exhaust, controlled by local timer switch, simultaneously turns HRV/ERV on high speed. Suggested use: bathroom and shower areas.

**Constant Exhaust Registers:** Airflows remain constant while other zones are turned on and HRV/ERV runs at high speed. Suggested use: laundry areas and pet rooms.

### DIMENSIONS HRV200SRD

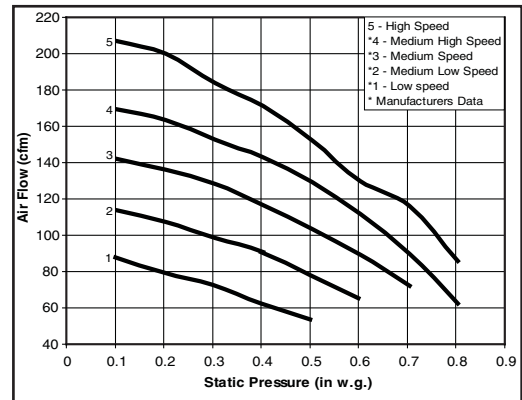
inches (mm)



\*All Duct Connections 6" (150 mm)

| Performance (HVI certified)<br>Net supply air flow in cfm (L/s) against external static pressure |               |      |
|--|---------------|------|
| E.S.P.<br>(external static pressure)   | [cfm (L/s)]   |      |
| @ 0.1" (25 Pa)   | 207           | (97) |
| @ 0.2" (50 Pa)   | 200           | (94) |
| @ 0.3" (75 Pa)   | 184           | (87) |
| @ 0.4" (100 Pa)  | 171           | (80) |
| @ 0.5" (125 Pa)  | 152           | (71) |
| @ 0.6" (150 Pa)  | 130           | (61) |
| @ 0.7" (175 Pa)  | 116           | (55) |
| @ 0.8" (200 Pa)  | 86            | (40) |
| Max. Temperature Recovery  | 74%           |      |
| Sensible Effectiveness<br>@ 66 cfm (31 L/s)  | 32°F (0°C)    | 74%  |
| *Sensible Efficiency<br>@ 66 cfm (31 L/s)  | 32°F (0°C)    | 64%  |
| Sensible Efficiency<br>@ 109 cfm (51 L/s)  | -13°F (-25°C) | 62%  |
| VAC @ 60HZ   | 120           |      |
| WATTS / Low speed.   | 87            |      |
| WATTS / High speed   | 164           |      |
| Amp rating   | 1.4           |      |

\*Sensible Efficiency – thermal \*\*Latent Efficiency – moisture  
Note: Effectiveness – based on temp. differential between the 2 airstreams  
Efficiency – takes into account all power inputs



All Duct Connections  
6" (160 mm)

All units conform to CSA and UL standards.

#### WARRANTY

Units carry a fifteen (15) year warranty on the heat recovery core and a two (2) year replacement parts warranty.

Date: \_\_\_\_\_  
 Tag: \_\_\_\_\_ Qty: \_\_\_\_\_  
 Project: \_\_\_\_\_  
 Engineer: \_\_\_\_\_

Contractor: \_\_\_\_\_  
 Supplier: \_\_\_\_\_  
 Quote#: \_\_\_\_\_  
 Submitted by: \_\_\_\_\_

**ENGINEERING DATA**

**THERMALLY CONDUCTIVE, PATENTED ALUMINUM CORE**

The cross-flow heat recovery core transfers heat between the two airstreams. The two cores are arranged for highly efficient counter current airflow.

**MOTORS AND BLOWERS**

Each air stream has one centrifugal blower driven by a common PSC motor. 5 speed fan operation.

**FILTERS**

Washable air filters in exhaust and supply air streams.

**MOUNTING THE HRV**

Four threaded inserts at corners of case designed to accept four reinforced polyester straps that are supplied with the unit.

**DEFROST**

Damper defrost system.

**CASE**

Twenty gauge prepainted galvanized steel (G60) for superior corrosion resistance. Insulated to prevent exterior condensation. Drain connections 2 - 1/2" (12 mm) OD.

**WEIGHT** 106 lbs (48 Kg) **SHIPPING WEIGHT** 108 lbs (49 Kg)

**PREMIUM SERIES ELECTRONICS**

- Built-in Relay for Interfacing to furnace
- Built-in Dehumidistat disable feature

**CONTROLS & ELECTRONICS**

The **Premium Series Digital Control** (Model ADXC-II) is included with unit and can be wall mounted in a central location of the home.

- 2 Speed Operation on each mode
- 2 user selectable operational modes: Continuous Ventilation and 20 ON/40 OFF
- Adjustable Dehumidistat function built into the main wall control
- Connected to 3 wire 20 gauge low voltage wire

**OPTIONAL PROGRAMMABLE CONTROL**

**Premium Series Digital Control** (Model APVC) - contains all the features of the Premium Series Digital Control with 5 speeds and 7/24 programmable ventilation, (3 wire) min 20 gauge wire max 100' length.

**OPTIONAL TIMERS**

**DET-II 20/40/60 Minute Timer** - Initiates high speed ventilation for 20, 40, or 60 minutes, (3 wire) min 20 gauge wire max 100' length.

**28998 Mechanical Timer** - Initiates High speed ventilation for up to 60 minutes, (2 wire) min 20 gauge wire max 100' length.

**OPTIONAL ACCESSORIES**

**DH-II Dehumidistat** - Initiates high speed ventilation when the indoor humidity level is above the set point. (3 wire) 20 gauge wire (min.) 100' length

**22026 Weatherhoods**, Two - 6" (150 mm) c/w 1/4" (6 mm) mesh screen

**ZRT-1 Zone Register Terminal** permits intermittent ventilation control at any exhaust terminal, controlled by local timer switch, simultaneously turns HRV/ERV on high speed. Suggested use: bathrooms.

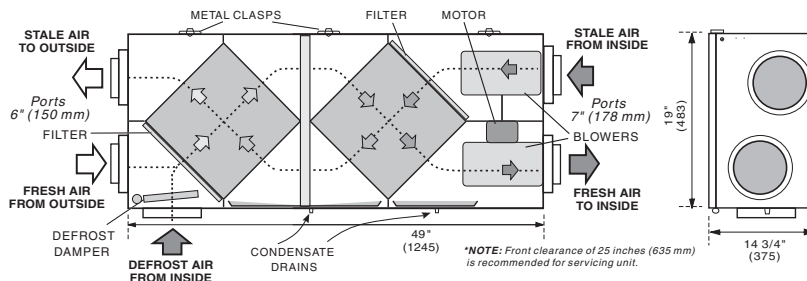
**ZRT-2 Zone Register Terminal** permits constant low airflow with boost exhaust, controlled by local timer switch, simultaneously turns HRV/ERV on high speed. Suggested use: bathroom and shower areas.

**Constant Exhaust Registers:** Airflows remain constant while other zones are turned on and HRV/ERV runs at high speed. Suggested use: laundry areas and pet rooms.

**DIMENSIONS**

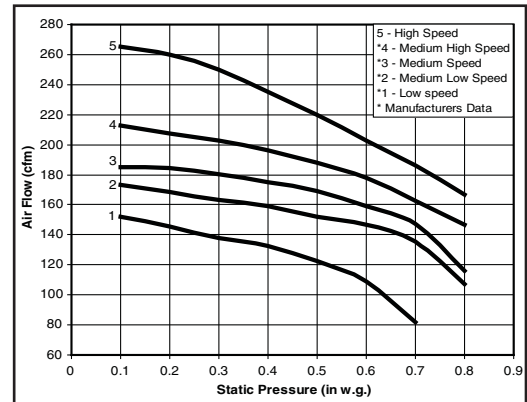
**HRV300DDD**

inches (mm)



| <b>Performance</b> (HVI certified)<br><i>Net supply air flow in cfm (L/s) against external static pressure</i> |                    |     |
|--|--------------------|-----|
| <i>E.S.P</i><br><i>(external static pressure)</i>  | <i>[cfm (L/s)]</i> |     |
| @ 0.1" (25 Pa)   | 265 (125)          |     |
| @ 0.2" (50 Pa)   | 260 (123)          |     |
| @ 0.3" (75 Pa)   | 250 (118)          |     |
| @ 0.4" (100 Pa)  | 235 (111)          |     |
| @ 0.5" (125 Pa)  | 220 (104)          |     |
| @ 0.6" (150 Pa)  | 203 (96)           |     |
| @ 0.7" (175 Pa)  | 186 (88)           |     |
| @ 0.8" (200 Pa)  | 167 (79)           |     |
| Max. Temperature Recovery  | 90%                |     |
| Sensible Effectiveness   |                    |     |
| @ 119 cfm (56 L/s)   | 32°F (0°C)         | 90% |
| *Sensible Efficiency   |                    |     |
| @ 119 cfm (56 L/s)   | 32°F (0°C)         | 79% |
| *Sensible Efficiency   |                    |     |
| @ 125 cfm (59 L/s)   | -13°F (-25°C)      | 75% |
| VAC @ 60HZ   | 120                |     |
| WATTS / Low speed.   | 150                |     |
| WATTS / High speed   | 333                |     |
| Amp rating   | 2.9                |     |

\*Sensible Efficiency – thermal \*\*Latent Efficiency – moisture  
Note: Effectiveness – based on temp. differential between the 2 airstreams  
Efficiency – takes into account all power inputs



All units conform to  
CSA and UL standards.

**WARRANTY**

Units carry a fifteen (15) year warranty on the heat recovery core and a two (2) year replacement parts warranty.

Date: \_\_\_\_\_ Contractor: \_\_\_\_\_

Tag: \_\_\_\_\_ Qty: \_\_\_\_\_ Supplier: \_\_\_\_\_

Project: \_\_\_\_\_ Quote#: \_\_\_\_\_

Engineer: \_\_\_\_\_ Submitted by: \_\_\_\_\_



### ENGINEERING DATA LATENT RECOVERY/MOISTURE TRANSFER CORE

The cross-flow energy recovery core transfers heat and water vapor between the two airstreams. It is easily removed for cleaning or service.

### MOTORS AND BLOWERS

Each air stream has one centrifugal blower driven by a common PSC motor. 5 speed fan operation.

### FILTERS

Washable air filters in exhaust and supply air streams.

### MOUNTING THE ERV

Four threaded inserts at corners of case designed to accept four PVC reinforced polyester straps that are supplied with the unit.

### CASE

Twenty gauge prepainted galvanized steel (G60) for superior corrosion resistance. Insulated to prevent exterior condensation.

**WEIGHT 75 lbs (34Kg) SHIPPING WEIGHT 77 lbs (38 Kg)**

### PREMIUM SERIES ELECTRONICS

- Built-in Relay for Interfacing to furnace
- Built-in Dehumidistat disable feature

### CONTROLS & ELECTRONICS

The **Premium Series Digital Control** (Model ADXC-II) is included with unit and can be wall mounted in a central location of the home.

- 2 Speed Operation on each mode
- 2 user selectable operational modes: Continuous Ventilation and 20 ON/40 OFF
- Adjustable Dehumidistat function built into the main wall control
- Connected to 3 wire 20 gauge low voltage wire

### OPTIONAL PROGRAMMABLE CONTROL

**Premium Series Digital Control** (Model APVC) - contains all the features of the Premium Series Digital Control with 5 speeds and 7/24 programmable ventilation, (3 wire) min 20 gauge wire max 100' length

### OPTIONAL TIMERS

**DET-II 20/40/60 Minute Timer** - Initiates high speed ventilation for 20, 40, or 60 minutes, (3 wire) min 20 gauge wire. Max 100' length.

**28998 Mechanical Timer** - Initiates High speed ventilation for up to 60 minutes, (2 wire) min 20 gauge wire. Max 100' length.

### OPTIONAL ACCESSORIES

**DH-II Dehumidistat** - Initiates high speed ventilation when the indoor humidity level is above the set point. (3 wire) min 20 gauge wire Max 100' length.

**22026 Weatherhoods**, Two - 6" (150 mm) c/w 1/4" (6 mm) mesh screen

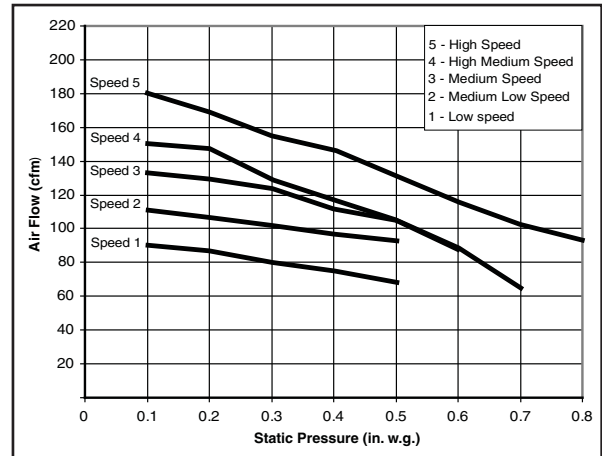
**ZRT-1 Zone Register Terminal** permits intermittent ventilation control at any exhaust terminal, controlled by local timer switch, simultaneously turns HRV/ERV on high speed. Suggested use: bathrooms.

**ZRT-2 Zone Register Terminal** permits constant low airflow with boost exhaust, controlled by local timer switch, simultaneously turns HRV/ERV on high speed. Suggested use: bathroom and shower areas.

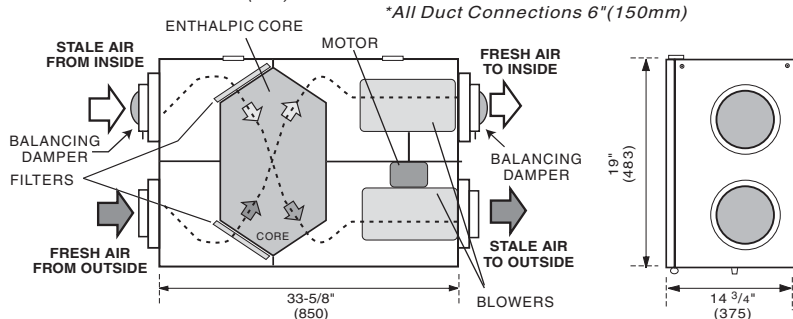
**Constant Exhaust Registers:** Airflows remain constant while other zones are turned on and HRV/ERV runs at high speed. Suggested use: laundry areas and pet rooms.

| Performance (HVI certified)<br>Net supply air flow in cfm (L/s) against external static pressure |             |      |
|--|-------------|------|
| E.S.P.<br>(external static pressure)   | [cfm (L/s)] |      |
| @ 0.1" (25 Pa)   | 180         | (85) |
| @ 0.2" (50 Pa)   | 169         | (79) |
| @ 0.3" (75 Pa)   | 157         | (74) |
| @ 0.4" (100 Pa)  | 146         | (69) |
| @ 0.5" (125 Pa)  | 132         | (62) |
| @ 0.6" (150 Pa)  | 118         | (55) |
| @ 0.7" (175 Pa)  | 101         | (47) |
| @ 0.8" (200 Pa)  | 82          | (39) |
| Sensible Effectiveness   |             |      |
| @ 66 cfm (31 L/s)  | 32°F (0°C)  | 81%  |
| *Sensible Efficiency   |             |      |
| @ 66 cfm (31 L/s)  | 32°F (0°C)  | 72%  |
| Total Efficiency   |             |      |
| @ 117 cfm (55L/s)  | 95°F (35°C) | 50%  |
| VAC @ 60HZ   | 120         |      |
| WATTS / Low speed.   | 68          |      |
| WATTS / High speed   | 97          |      |
| Amp rating   | 1.4         |      |

\*Sensible Efficiency - thermal \*\*Latent Efficiency - moisture  
Note: Effectiveness - based on temp. differential between the 2 airstreams  
Efficiency - takes into account all power inputs



### DIMENSIONS ERV200S inches (mm)



All units conform to  
CSA and UL standards.

### WARRANTY

Units carry a five (5) year warranty on the energy recovery core and a two (2) year replacement parts warranty.

\*NOTE: Front clearance of 25 inches (635 mm) is recommended for servicing unit.

Date: \_\_\_\_\_  
 Tag: \_\_\_\_\_ Qty: \_\_\_\_\_  
 Project: \_\_\_\_\_  
 Engineer: \_\_\_\_\_

Contractor: \_\_\_\_\_  
 Supplier: \_\_\_\_\_  
 Quote#: \_\_\_\_\_  
 Submitted by: \_\_\_\_\_

## Controlling your HRV/ERV

Today's modern, tight homes require fresh outdoor air to maintain a healthy indoor air environment. The amount of ventilation you require in your home will depend upon:

- the number of occupants and their activity levels,
- the way your home was built.
- your personal preferences for fresh air,

The HRV/ERV introduces fresh air to your home while recovering energy from the air it exhausts. Specifically, an HRV/ERV that is properly installed, operated and maintained will:

- exhaust stale, contaminated air
- recover the majority of the energy from the exhausted stale air
- use the recovered energy to preheat or precool outside air that is drawn into the house
- distribute the fresh air throughout the house

## HOW MUCH VENTILATION DO I NEED?

During seasons when your windows and doors are closed (winter, and summer if air conditioned), the HRV/ERV should be set to operate continuously on low speed with the option of going to high speed as the need arises. For example: if you are entertaining and there is a large number of people present, the unit should be switched temporarily to high speed.

You may wish to use an intermittent operational mode if your home is unoccupied (20 minutes ON / 40 minutes OFF).

## How the Dehumidistat Works

Often today's well insulated and tight homes will have high indoor humidity levels during the heating season. High humidity levels are apparent from the visible condensation on windows. The amount of condensation on the windows will increase as outdoor temperatures drop.

Your HRV will reduce indoor humidity levels when outdoor air is drier than indoor air. This usually occurs during the heating season when outdoor temperatures are less than 15°C (59°F).

Wall controls have a dehumidistat which can be set to achieve a further dehumidification effect from your HRV. High speed ventilation will be initiated upon exceeding the dehumidistat set point. Once the humidity in the house is reduced, the HRV will revert back to its previous setting.

We suggest operating the HRV for the first few days without use of the dehumidistat function to observe if a further dehumidification effect will be required. The dehumidistat operates in % of RH (relative humidity) with 80 being high and 20 being low. Set the Dehumidistat to 80% to disable. If, after a few days, further dehumidification is required (the house is still too humid), set the humidity level to a lower amount.

### Dehumidistat Notes:

Your HRV will reduce indoor humidity levels when outdoor air is dryer than indoor air. This usually occurs during the heating season when outdoor temperatures are less than 15°C (59°F).

The average person is comfortable between 30-50% RH.

The dehumidistat should be set to OFF for all seasons except the heating season. OFF is achieved by setting the dehumidistat to 80.

The dehumidistat function will be disabled if outdoor temperatures exceed 15°C (59°F) for a 24 hour period.

The dehumidistat function will be re-enabled if the unit is unplugged for 3 minutes or if the outdoor temperature drops below 15°C (59°F) for a 24 hour period.

## Glossary

**DEFROST MODE** - to ensure reliable operation during cold weather, the HRV/ERV will automatically cycle through its defrost mode as needed.

**DEHUMIDISTAT** - a control device that senses the amount of moisture in the air and activates high speed ventilation when the air moisture level in the home exceeds the set point.

**RESET** - whenever resetting of the HRV/ERV is required, simply disconnect power for 30 seconds. The Self Test will occur when the HRV/ERV is re connected.

**SELF TEST** - each time the HRV/ERV is powered/energized the self test function will automatically initiate. During the self test the HRV/ERV will cycle through all the speeds available (1-5), test the damper motor operation and will default back to the previous operational mode and speed selection. Total self test duration is approximately 90 seconds.

**STANDBY MODE** - the HRV/ERV is powered/energized and waiting for fan operation to be initiated. For example, the HRV is set a Continuous Ventilation Operational Mode at Speed 0.

**THERMISTOR** - the HRV/ERV's temperature sensor which measures electrical resistance in a known manner, as outdoor temperatures fluctuate.

## MODEL ADXC-II

THE PREMIUM SERIES DIGITAL CONTROL (INCLUDED WITH UNIT) OFFERS MANY ADVANCED FEATURES

### Key Features

- 2 Speed Fan setting (Low-1/High-2)
- Standby setting (Fan speed 0)
- Electronic Dehumidistat
- Four Selectable Modes of Operation
  - 20 min. ON / 40 min. off
  - 20 min. ON / 40 min. recirculate \*
  - Continuous Ventilation
  - Continuous Circulation \*
- 20 / 40 / 60 High Speed override button
- Instruction Card is inserted in the control
- Easy to read LCD Screen
- Slim-line design
- Connect to 3 wire 20 gauge low voltage wire

### Setting the Control

1. Press and release MODE button until the FAN symbol appears on the screen. Press SET.
2. SCROLL (using Up/Down Arrows) to select desired fan speed (0, 1, 2). Press SET.
3. SCROLL to select the desired operational mode (VENT, 20/40, 20/40 RECIRC\*, RECIRC\*, OFF). Press SET. (Refer to Manual for explanation of operational modes.)

### 20/40/60 Minute High Speed Timer

This function temporarily initiates high speed ventilation for 20, 40 or 60 minutes. Press FAN button once for 20, twice for 40 and three times for 60 minutes.

### Setting the Dehumidistat

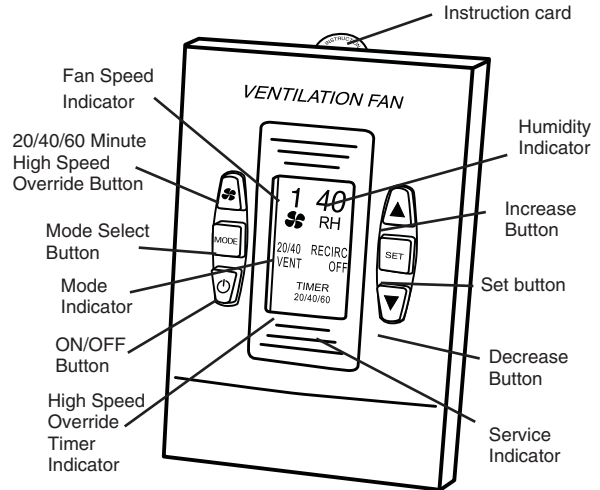
Refer to "How the Dehumidistat Works" in this manual before setting the Dehumidistat.

1. Press and release MODE until "RH" and a number flashes. SCROLL to desired number. Press MODE to exit. Refer to the unit's Operation & Installation Manual for instructions on how the Dehumidistat works.
2. Press MODE to return to operational features.

The Premium Series Digital Control has 4 Operational Modes\* and 2 speeds on each mode to adjust indoor ventilation levels. Experiment with the ventilation levels in your home to evaluate the best amount of ventilation to suit your home and preferences.

#### I. Continuous Ventilation Mode

This is the most popular mode since it provides continuous ventilation within the home. You may, for example, select Continuous Ventilation at high speed for high household activity levels or Continuous Ventilation for lower activity levels.



Connects to 3 wire 20 gauge low voltage wire

#### II. 20 minutes ON, 40 minutes OFF Mode

This Operational Mode will provide 20 minutes of ventilation each hour. You may wish to use this ventilation mode in low speed for low household activity levels or if the home is unoccupied.

#### III. 20 minutes ON, 40 minutes Recirculation Mode\*

This Operational Mode provides 20 minutes of ventilation (fresh air) and 40 minutes of recirculated air. Use this mode only if your HRV/ERV is not connected to a forced air system (the forced air system already circulates household air).

#### IV. Continuous Recirculation Mode\*

This Operational Mode recirculates your household air (no ventilation). Use this mode only if HRV/ERV is not connected to a forced air system.

### How to Synchronize the Humidity Setting on the Premium Series Digital Control

The wall control has a feature that will allow it to be synchronized with other humidity instruments in your home.

1. Turn off the control with the ON/OFF Button.
2. Simultaneously press and release the ON/OFF Button and the 20/40/60 Minute High Speed Override Button.
3. Use the Increase/Decrease Buttons to adjust the Humidity indicator on the display screen to the number of degrees difference between your humidity measuring device. Minus is indicated by flashing.
4. Press the Set button.

\*Recirculation not available on all models.

## MODEL APVC

The Optional Premium Programmable Control is fully digital and allows you to program when and how much fresh air enters your home.

### Key Features

- 24 / 7 programmable ventilation
- 4 programmable events per day
- 5 Speed Fan setting
- Electronic Dehumidistat
- Four Selectable Modes of Operation
  - 20 min. ON / 40 min. off
  - 20 min. ON / 40 min. recirculate \*
  - Continuous Ventilation
  - Continuous Recirculation \*
- 20 / 40 / 60 High Speed override timer
- Service/Maintenance Reminder display
- Backlit LCD screen is easy to read

### Setting Date & Time

1. Press and release MODE Select Button until "TIME" and "SET" appear on the screen. Press SET Button.
2. The letter for the day of the week flashes. SCROLL (using Up/Down Arrows) to the correct day of the week. Press SET Button.
3. The hour and "AM" or "PM" flashes. SCROLL to the correct hour using the Increase or Decrease Buttons. Press SET button.
4. The minutes will flash. SCROLL to the correct minute. Press SET button to complete entry.

### Programming Your Control

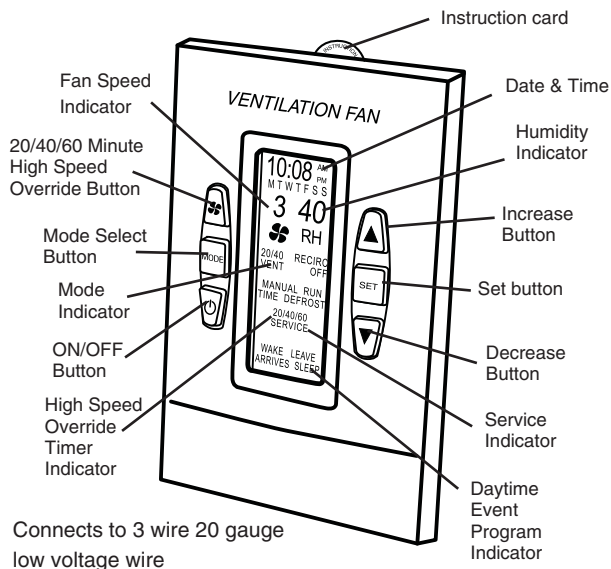
1. Press and release the MODE Button until "PROGRAM SET" appears. Press SET Button.
2. Weekday letters (MTWTF) will flash. Press SET Button.
3. "WAKE" flashes. Press SET Button.
4. "AM" or "PM" flashes. SCROLL to desired time (in 20 minute intervals). Press SET Button.
5. "FAN" flashes. SCROLL to desired fan speed (0-5). Press SET Button.
6. "OFF" flashes. SCROLL to desired operation mode (VENT, 20/40, 20/40 RECIRC\*, RECIRC\*, OFF). Press SET Button two times. (Refer to "Selecting the Best Mode of Operation" in this manual for a description of operational modes.)
7. "LEAVE" flashes. Repeat steps 4 to 6 to program up to 4 events per day.
8. "SS" (Saturday & Sunday) Flashes repeat steps 3 to 7.
9. (Optional) M flashes. This can be used to program individual days of the week. Scroll to day and repeat steps 3 to 7.

\* RECIRC not available on all models.

### Running the Programmed Setting

Once the programming has been completed, activate the program.

- Press the MODE Button until "PROGRAM" and "RUN" are indicated.



## ATTENTION

Only one main control can be installed on your system.

### Setting the Dehumidistat

Refer to "How the Dehumidistat Works" in this manual before setting the Dehumidistat.

1. Press and release the MODE Button until "RH" and a number flashes. SCROLL using the Increase or Decrease Buttons to desired number (RH Set Point). Press the MODE Button to exit. Refer to "How the Dehumidistat Works" in this manual for a description of the functionality of the Dehumidistat.
2. Press the MODE Button to return to operational features.

### Manually Setting the Control

1. Press and release MODE until "MANUAL" and "RUN" are indicated. Press SET.
2. SCROLL to select desired fan speed (0-5). Press SET.
3. Use SCROLL to select the desired operational mode (VENT, 20/40, 20/40 RECIRC\*, RECIRC\*). Press SET.
4. The control will remain in the "MANUAL RUN" position until you change back to "PROGRAM RUN" (refer to "Running the Programmed Setting").

### 20/40/60 Minute High Speed Override Button

This function temporarily initiates high speed ventilation for 20, 40 or 60 minutes. Press FAN button once for 20, twice for 40 and three times for 60 minutes.

### Service Indicator

After 4 months, a 'SERVICE' indicator will appear. Refer to "Maintenance Routine for your HRV/ERV" in this manual.

To reset the service indicator:

- Press and release the Increase/Decrease buttons simultaneously. The "SERVICE" icons will flash for 5 seconds..
- Press SET within the 5 seconds and the service indicator resets.

## Optional Timers

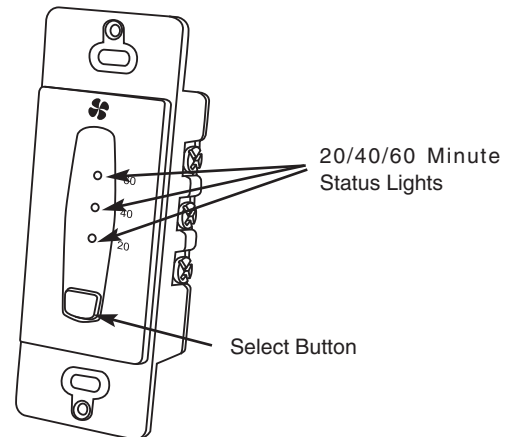
Depending on the type of HRV/ERV installation, you may have timers in areas such as restrooms. The timer will override the Operational Mode (regardless of the setting) and initiate high speed ventilation. Upon completion of the timer cycle, the HRV/ERV will return to your selected Operational Mode and speed setting.

### DET-II 20/40/60 Minute Timer

Initiates high speed ventilation for 20, 40 or 60 minutes. The 20/40/60 Minute Status Lights indicate high speed operation.

Lockout Mode is useful if you wish to disable the timer. Set lockout by holding the Select Button for 5 seconds. Unlock by holding for 5 seconds.

Connect to 3 wire 20 gauge low voltage wire. Mounts in a standard 2" x 4" electrical box.



## The DH-II Dehumidistat

### Key Features

- The Dehumidistat measures the indoor humidity level and will initiate high speed ventilation when the moisture level in the home exceeds the set point on the control.
- Once the humidity in the house is reduced, the HRV will revert back to its previous setting.
- The Dehumidistat should be set to OFF for all season except the heating season.
- Connect to 3 wire 20 gauge low voltage wire.

### Humidity Control

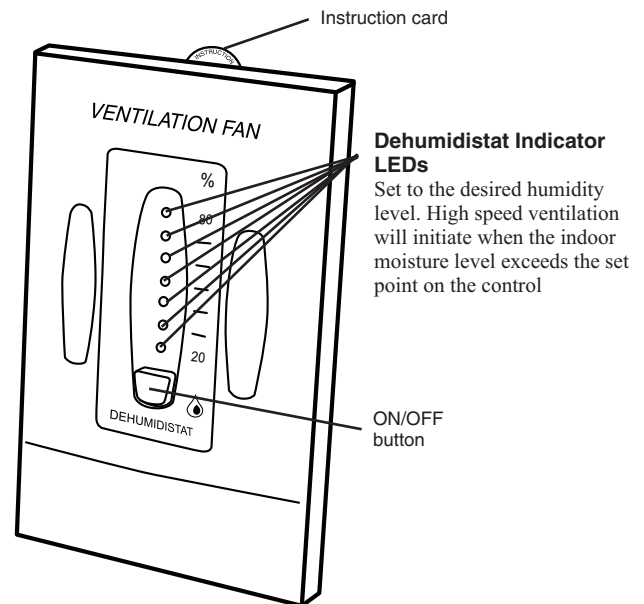
Your HRV will produce a dehumidifying effect when outdoor humidity levels are lower than indoor humidity levels. Never use the dehumidistat feature when outdoor temperatures are above 59 F (15 C).

Note: The indoor humidity level is measured at the control.

### Setting the Dehumidistat

Press and release the DEHUMIDISTAT button until the DEHUMIDISTAT LIGHT is at the desired setting. After 5 seconds the dehumidistat light will either flash or be on continuous.

A flashing light indicates the humidity level is higher than the setting and the unit is operating on high speed ventilation. A continuous light indicates the humidity level is lower than the setting. Refer to the unit's Operation & Installation Manual for instructions on how the Dehumidistat works.



### The Three Methods of Installation

The three methods of installation for the HRV/ERV system are:

- The Simplified installation.
- The Partially Dedicated Installation
- The Fully Dedicated Installation

### Simplified Installations

The Simplified Installation draws stale air from the cold air return duct of the air handler/furnace and introduces an equal amount of fresh air farther downstream into the cold air return. Refer to "*Simplified Installation Diagrams*".

The air handler/furnace blower must be running when the unit is operating for this system to be effective. Refer to "*Interlocking the HRV/ERV to an Air handler/Furnace Blower*".

### Partially Dedicated Installations

The Partially Dedicated Installation draws stale air from specific points in the house and introduces an equal amount of fresh air into the cold air return. Refer to "*Partially Dedicated Installation Diagrams*".

Stale air ducts should be installed in areas of the home where the poorest indoor air quality exists (bathrooms and kitchen). Each location with a stale air duct should have a timer to initiate high speed ventilation. Refer to "*Optional Timers*" in this manual.

The air handler/furnace blower should be running when the HRV/ERV is operating to evenly distribute the fresh air throughout the house. Refer to "*Interlocking the HRV/ERV to an Air handler/Furnace Blower*".

### Fully Dedicated Installations

The Fully Dedicated Installation draws stale air from specific points in the house and delivers fresh air to specific locations of the house. This system is not connected to an air handler/furnace. Refer to "*The Fully Dedicated Installation Diagrams*" in this manual.

Stale air ducts should be installed in areas of the home where the poorest indoor air quality exists (bathrooms and kitchen). Each location with a stale air duct should have a timer which will initiate high speed ventilation. Refer to "*Optional Timers*" in this manual.

Fresh air ducts should be installed to all bedrooms and living areas, excluding bathrooms, kitchen and utility areas. Grilles should be located high on a wall or in ceiling locations. Grilles that diffuse the air comfortably are recommended. Refer to "*Grilles*" in this manual. Special care should be taken in locating grilles if the floor is the only option available. Areas such as under baseboard heaters will help to temper the air.

### Installing the Ducting Between the HRV/ERV & Living Areas in the House

A well designed and installed ducting system will allow the HRV/ERV to operate at its maximum efficiency.

All ducts should be kept short and have as few bends or elbows as possible to maximize airflow. Forty-five degree elbows are preferred to 90° elbows. Use "Y" tees instead of straight tees whenever possible.

All duct joints must be fastened with screws, rivets or duct sealant and wrapped with mastic or quality duct tape to prevent leakage. Mastic is preferred but if duct tape is used, we recommend aluminum foil duct tape.

Galvanized (rigid) ducting from the HRV/ERV to the living areas in the house is recommended whenever possible although flexible duct can be used in moderation if necessary.

A short length (approximately 12 inches or 300mm) of non-metallic flexible insulated duct should be connected between the HRV/ERV and the supply/exhaust duct system to avoid possible noise transfer through the duct system.

All ducts running through attics and unheated spaces must be sealed and insulated to code.

## ATTENTION

**Applications such as greenhouses, atriums, swimming pools, saunas, etc. have unique ventilation requirements which should be addressed with an isolated ventilation system.**

**Simplified Installation  
(Return/Return Method)**

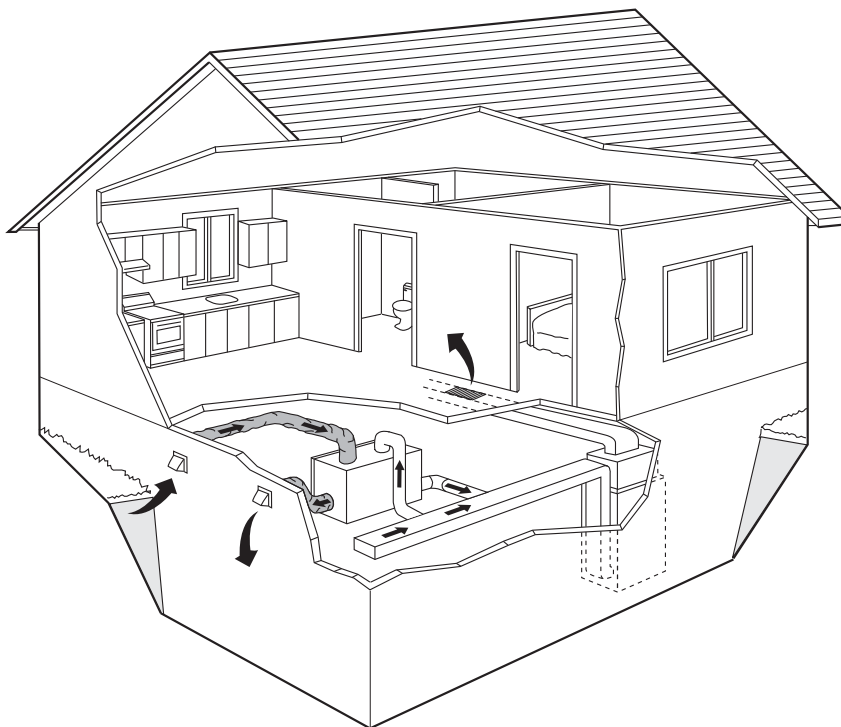
**Key Points**

- The HRV/ERV must be balanced.
- It is mandatory that the furnace blower run continuously or HRV/ERV operation be interlocked with the furnace blower.
- The duct configuration may change depending on the HRV/ERV model. See specifications for your unit.
- Check local codes / authority having jurisdiction for acceptance.

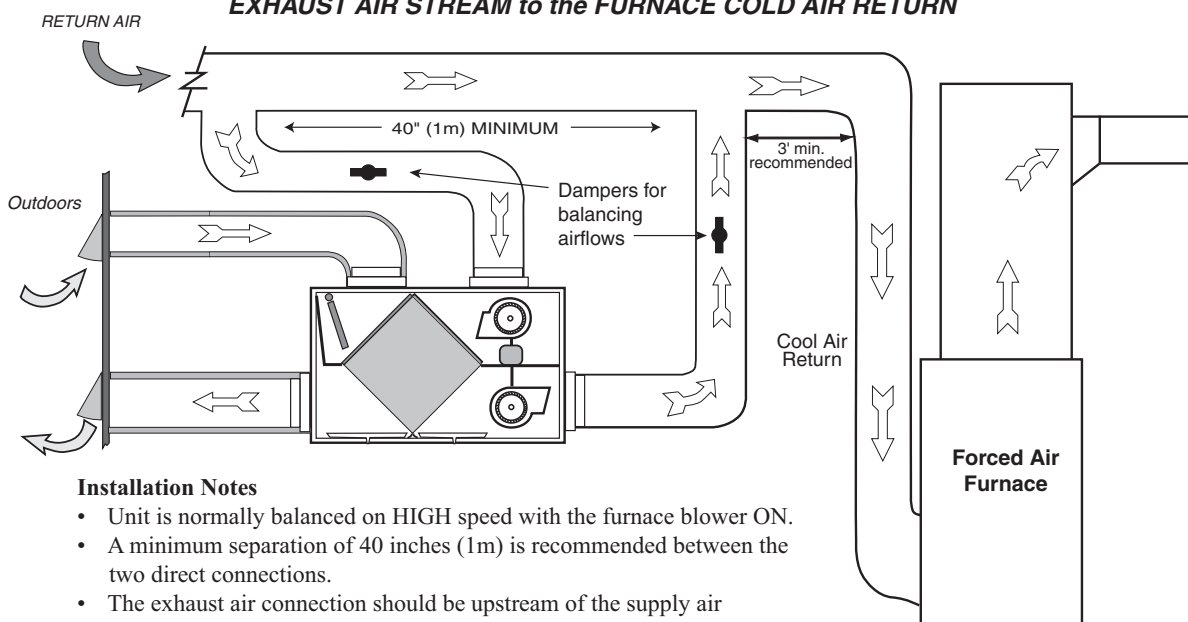
**Sizing the Ductwork**

It is the responsibility of the installer to ensure all ductwork is sized and installed as designed to ensure the system will perform as intended.

The amount of air (cfm) that an HRV/ERV will deliver is directly related to the total external static pressure (E.S.P.) of the system. Static pressure is a measure of resistance imposed on the blower by length of duct work plus the number of fittings used in the duct work.



**DIRECT CONNECTION of both the HRV/ERV SUPPLY AIR STREAM and EXHAUST AIR STREAM to the FURNACE COLD AIR RETURN**



**Installation Notes**

- Unit is normally balanced on HIGH speed with the furnace blower ON.
- A minimum separation of 40 inches (1m) is recommended between the two direct connections.
- The exhaust air connection should be upstream of the supply air connection to prevent exhausting any fresh air.
- Weatherhood arrangement is for drawing purposes only. Six feet (2m) minimum separation is recommended. The Weatherhood must also be 18" (460mm) above grade minimum.
- The airflow must be confirmed on site using the balancing procedures found in this manual

## Partially Dedicated Installation Diagrams

### Partially Dedicated System

This installation enables stale air to be drawn from the poorest air quality areas of the home (bathrooms, kitchen).

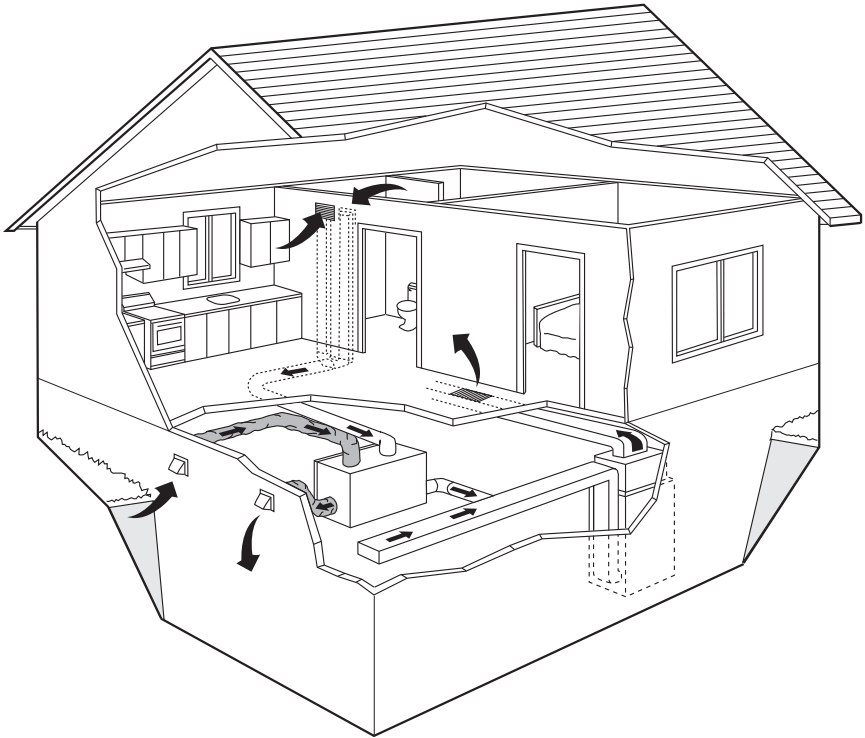
#### Key Points

- The HRV/ERV must be balanced.
- It is recommended that the furnace blower run continuously or HRV/ERV operation be interlocked with the furnace blower to evenly distribute the fresh air throughout the house.
- The duct configuration may change depending on the HRV/ERV model. See specifications for your unit.
- Check local codes / authority having jurisdiction for acceptance.

#### Sizing the Ductwork

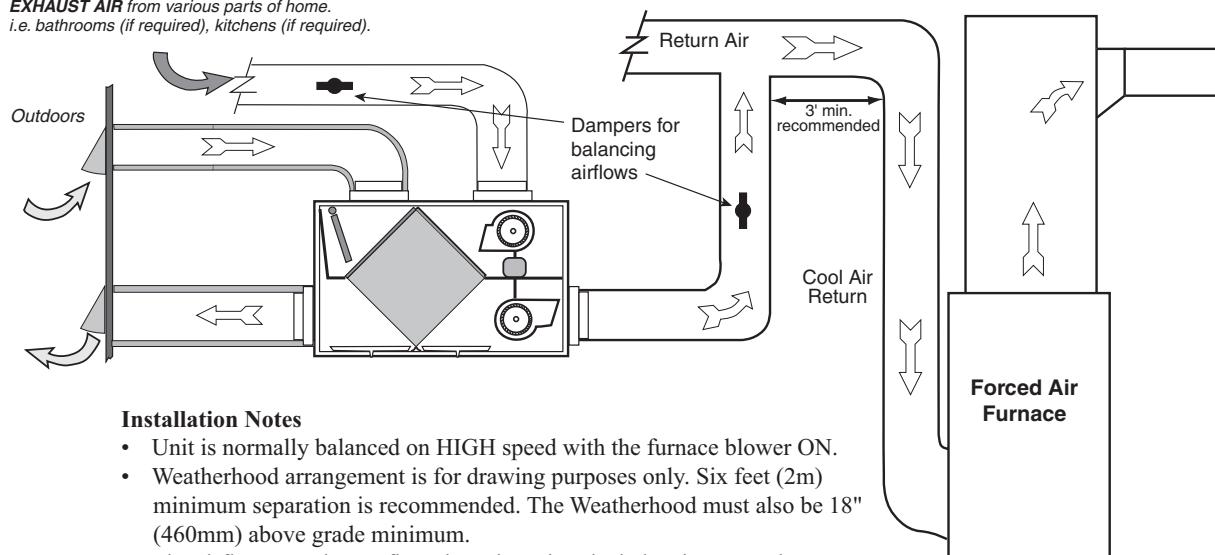
It is the responsibility of the installer to ensure all ductwork is sized and installed as designed to ensure the system will perform as intended.

The amount of air (cfm) that an HRV/ERV will deliver is directly related to the total external static pressure (E.S.P.) of the system. Static pressure is a measure of resistance imposed on the blower by length of duct work plus the number of fittings used in the duct work.



### **DIRECT CONNECTION of the SUPPLY AIR STREAM to the FURNACE COLD AIR RETURN** (Stale air drawn from key areas of home)

**EXHAUST AIR** from various parts of home.  
i.e. bathrooms (if required), kitchens (if required).



#### Installation Notes

- Unit is normally balanced on HIGH speed with the furnace blower ON.
- Weatherhood arrangement is for drawing purposes only. Six feet (2m) minimum separation is recommended. The Weatherhood must also be 18" (460mm) above grade minimum.
- The airflow must be confirmed on site using the balancing procedures found in this manual.



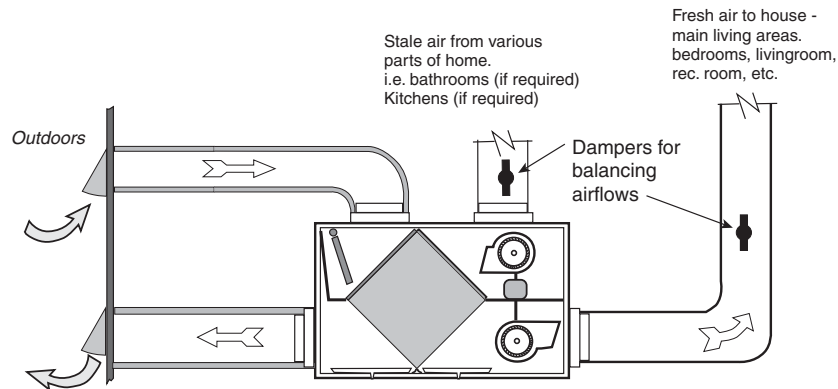
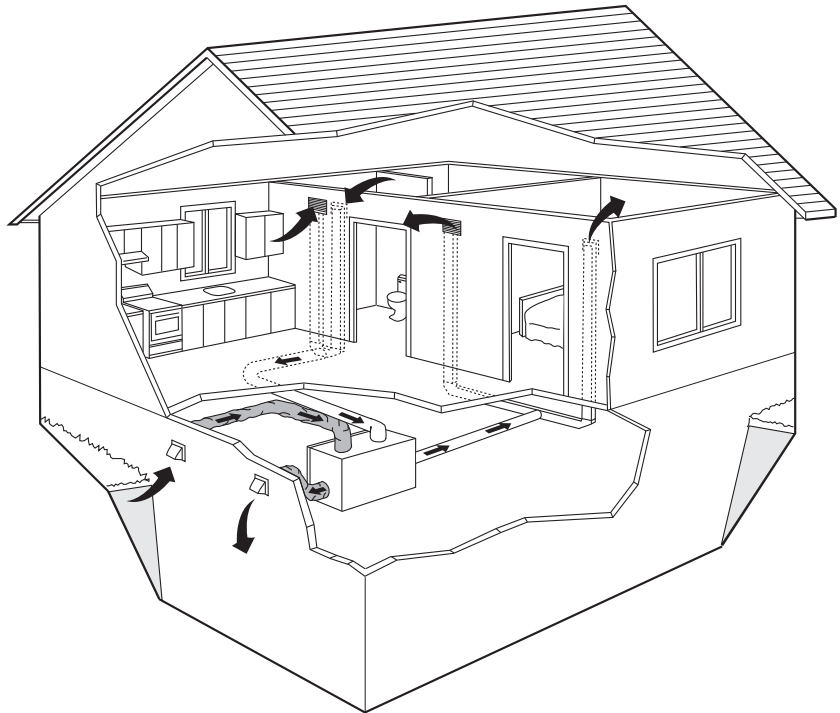
## Fully Dedicated Installation Diagrams

### Fully Dedicated System

This is a stand alone HRV/ERV system which is not connected to a force air system. Stale air is drawn from key areas of the home (bathroom, kitchen) while fresh air is supplied to main living areas

#### Key Points

- The HRV/ERV must be balanced.
- The duct configuration may change depending on the HRV/ERV model. See specifications for your unit.
- Check local codes / authority having jurisdiction for acceptance.



#### Installation Notes

- Unit is normally balanced on HIGH speed with the furnace blower ON.
- Weatherhood arrangement is for drawing purposes only. Six feet (2m) minimum separation is recommended. The Weatherhood must also be 18" (460mm) above grade minimum.
- The airflow must be confirmed on site using the balancing procedures found in this manual.

## Installation

### Location

The HRV/ERV must be located in a heated space where it will be possible to conveniently service the unit. Typically the HRV/ERV would be located in the mechanical room or an area close to the outside wall where the weatherhoods will be mounted. If a basement area is not convenient or does not exist, a utility or laundry room may be used.

Attic installations are not normally recommended due to:

- A) the complexity of work to install
- B) freezing conditions in the attic
- C) difficulty of access for service and cleaning

Sufficient clearance at the front of the access door is required for servicing the air filters and core. A minimum of 25" (635 mm) clearance is recommended so the door can be opened. Four PVC reinforced polyester hanging straps are provided for hanging the HRV/ERV from the basement floor joists.

### **⚠ WARNING**

**Improper installation, adjustment, alteration, service or maintenance can cause property damage, personal injury or loss of life. Installation and service must be performed by a qualified installer or service agency.**

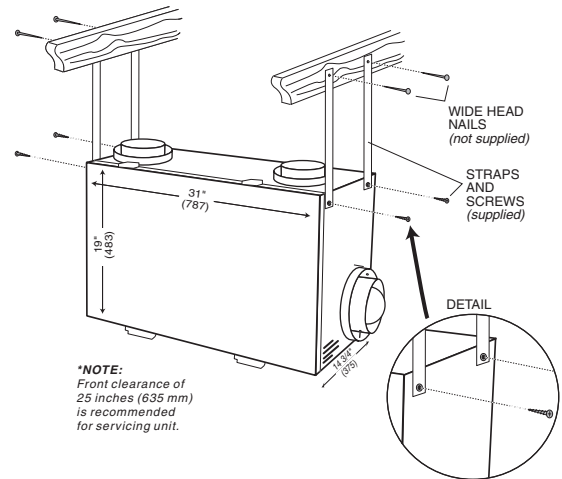
### Suspending the HRV/ERV

The hanging straps should be attached to the unit at the top end corners (mounting screws are already located on the HRV/ERV case). Securely fasten the other end of the straps to the floor joists with wide head nails (not supplied), making sure the unit is level. The straps are designed to reduce the possibility of noise, resonance or harmonics; therefore using the full length of the strap between the HRV/ERV and the floor joists is recommended.

### **⚠ CAUTION**

**Unit must be installed level to ensure proper condensate drainage. Due to the broad range of installation and operational conditions, consider the possibility of condensation forming on either the unit or connecting ducting. Objects below the installation may be exposed to condensate.**

### Illustration of Suspending the HRV/ERV



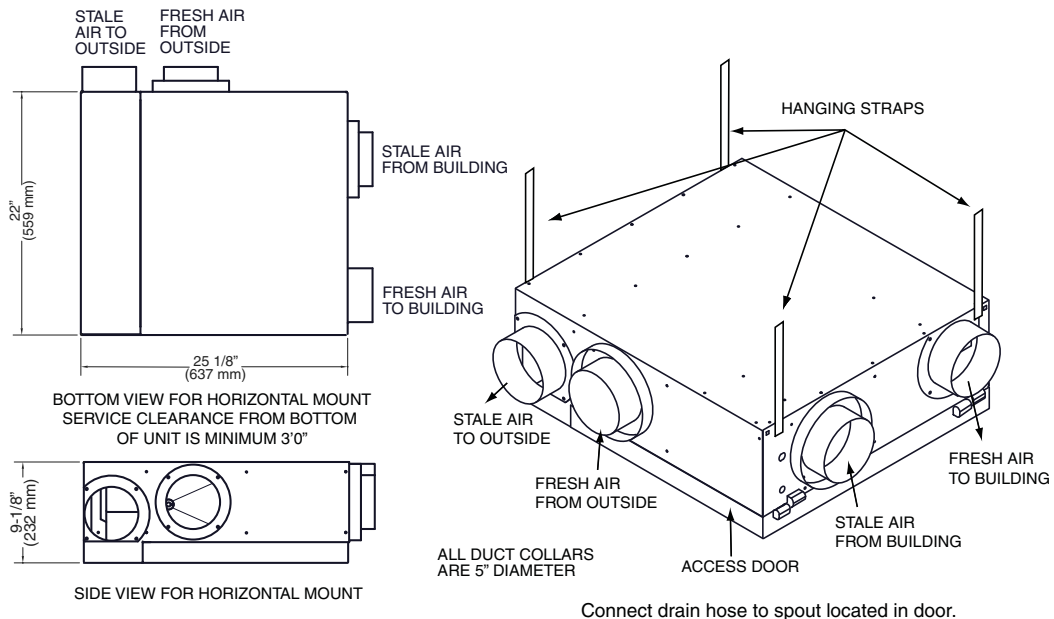
### Electrical

The HRV/ERV should be plugged into a standard designated (120VAC) electrical outlet with ground. It is not recommended that an extension cord be used for this appliance. If further wiring is required, then a licensed electrician should make all electrical connections. It is recommended that a separate 15 amp/120 volt circuit be used.

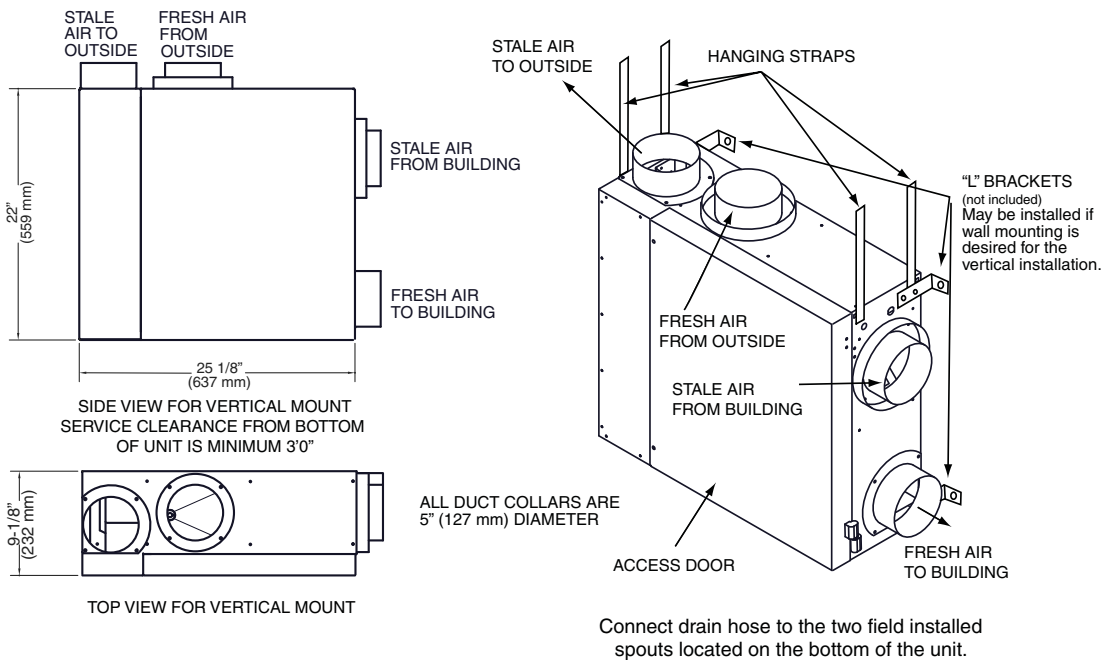
### WARNING:

In order to prevent electric shock when cleaning or servicing the HRV/ERV, it is extremely important to confirm the polarity of the power line that is switched by the safety (disconnect) switch. The hot line (black) is the proper line to be switched. To confirm the proper polarity, use a voltmeter or test lamp to ensure there is no power after the switch when the door is open. Check between that point and ground (on the cabinet). This must be done as dwellings are occasionally wired improperly. Always make sure that the HRV/ERV is properly grounded.

**Option 1 - Horizontal Duct Configuration Dimensions** inches



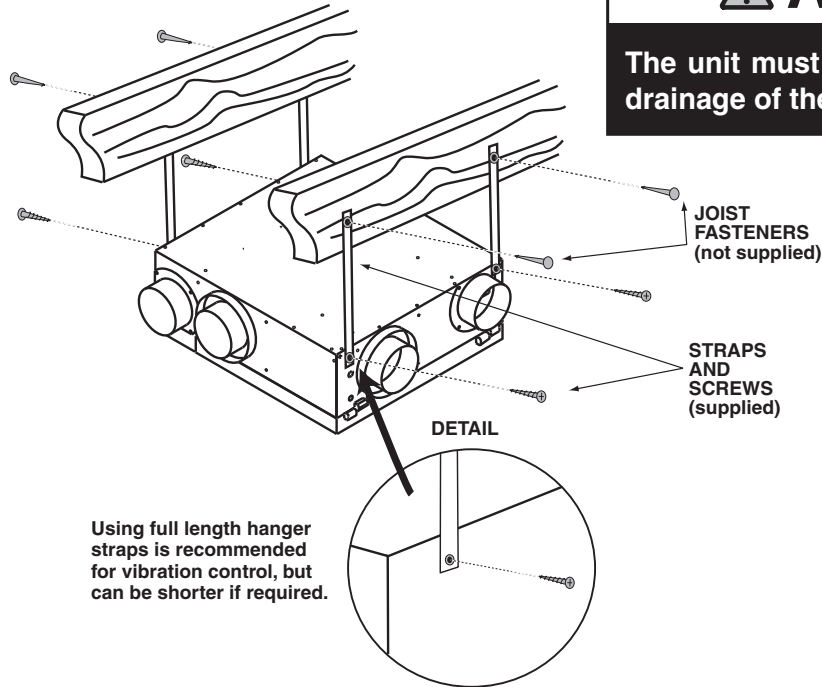
**Option 2 - Vertical Duct Configuration Dimensions** inches



The HRV can be installed horizontally or vertically as illustrated on the following pages. The unit should be suspended using the provided hanging straps. The unit must be level for proper condensate drainage.

Sufficient clearance below the access door is required for servicing the air filters and core. A minimum of 25" (635mm) clearance is recommended so the door can be removed. Four PVC reinforced polyester hanging straps are provided for hanging the HRV.

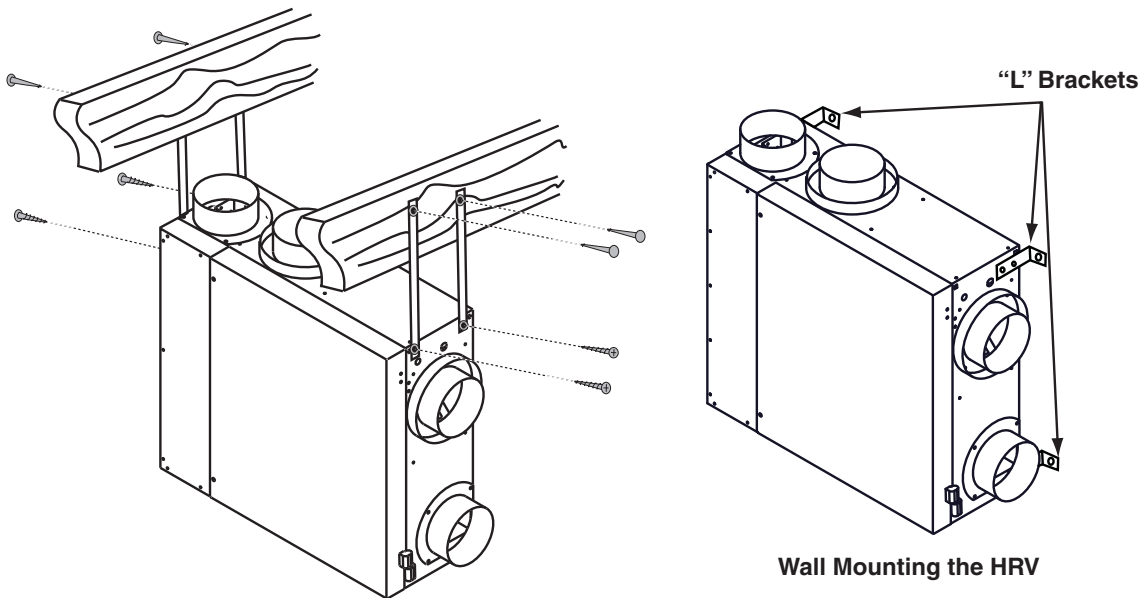
**Horizontal Installation**



**⚠ ATTENTION**

The unit must be mounted level for proper drainage of the condensate pans.

**Vertical Installation**



**Suspending the HRV120SRD**

The hanging straps should be attached to the unit at the top end corners (mounting screws are already located on the HRV case). Securely fasten the other end of the straps to the ceiling making sure the UNIT IS LEVEL. The straps are designed to reduce the possibility of noise, resonance or harmonics; therefore using the full length of the strap between the HRV and the floor joists is recommended.

"L" BRACKETS (not included) may be installed if wall mounting is desired for the vertical installation.

It is important to isolate the "L" BRACKET from the attached surface to minimize vibration.

Use the hanging strap hardware to attach the brackets. Do not drill additional holes in the HRV.

## Drain Connection

### Drain Connection

The HRV may produce some condensation during a defrost cycle. This water should flow into a nearby drain, or be taken away by a condensate pump.

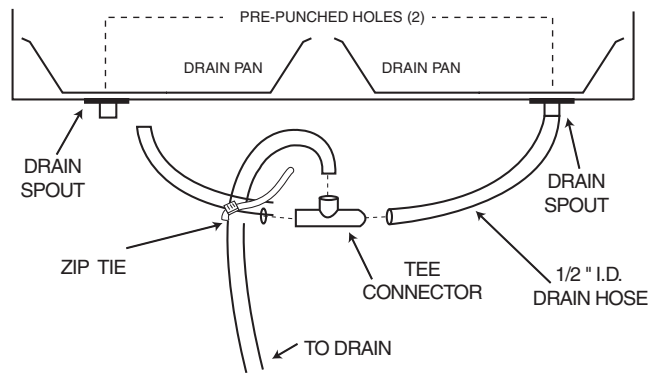
## ⚠ CAUTION

The HRV and all condensate lines must be installed in a space where the temperature is maintained above the freezing point or freeze protection must be provided.

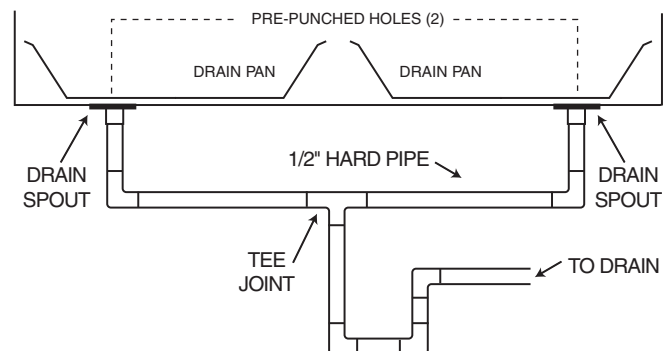
The HRV cabinet has pre-punched holes for the drain (see below). Insert the drain spout through the hole in the drain pan. Be sure to install the "O ring" which seals each spout to the pan. **HAND TIGHTEN** the washer and lock nut which hold the drain spout in place.

Construct a P-Trap using the plastic tee connector. Cut two lengths of 1/2" drain hose (not included) and connect the other ends to the two drain spouts. Position the "T" fitting to point upward and connect the drain line. Tape or fasten base to avoid any kinks. Pour a cup of water into the drain pan of the HRV after the drain connection is complete. This creates a water seal which will prevent odors from being drawn up the hose and into the fresh air supply of the HRV.

### DRAIN HOSE PLUMBING



### HARD PIPE PLUMBING



*Note: Secondary drain pan may be required to protect from condensate leakage.*

## ⚠ CAUTION

Drain trap and tubing **MUST** be below bottom of door with 1/4" per foot downwards slope away from unit.

## Grilles

Adjustable grilles can be used to balance the flow rates into and out of various rooms. The grilles should not be adjusted after balancing the unit.

Grilles or diffusers should be positioned high on the wall or in the ceiling. Kitchen Exhaust grilles must never be connected to the range hood. They should be installed at least 4 feet (1.2 m) horizontally away from the stove.

Field supplied balancing dampers can be installed external to the unit to balance the amount of stale air being exhausted with the amount of fresh air being brought into the house. Refer to Air flow Balancing section.

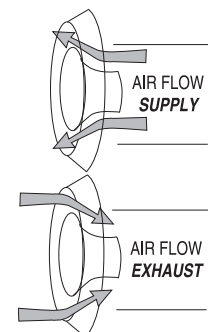
## ⚠ CAUTION

Do not mount exhaust grille within 4' (1.2m) (horizontally) of a stove to prevent grease from entering HRV.

**ZRT Zone Registers** are used to balance exhaust flow rates and provide the ability to "boost" the flow rate from each zone as needed.

The Algrille is a round, fully adjustable grille that provides superior, quiet air distribution.

- 4" (100 mm) Part No. 40104
- 5" (125 mm) Part No. 40105
- 6" (150 mm) Part No. 40106
- 8" (200 mm) Part No. 40108



## Weatherhood Installation

### Installing the Ducting from the Weatherhoods to the HRV/ERV

The inner and outer liners of the flexible insulated duct must be clamped to the sleeve of the weatherhoods (as close to the outside as possible) and the appropriate port on the HRV/ERV. It is very important that the fresh air intake line be given special attention to make sure it is well sealed. A good bead of high quality caulking (preferably acoustical sealant) will seal the inner flexible duct to both the HRV/ERV port and the weatherhood prior to clamping.

To minimize air flow restriction, the flexible insulated duct that connects the two outside weatherhoods to the HRV/ERV should be stretched tightly and be as short as possible.

Twisting or folding the duct will severely restrict air flow.

Hard (rigid) ducting which has been sealed and insulated should be used for runs over 10' (3.3 m). Refer to your building code.

### Intake Weatherhood Requirements

- Should be located upstream (if there are prevailing winds) from the exhaust outlet
- At least 6' (2 m) from the exhaust weatherhood
- At least 6' (2 m) away from dryer vents and furnace exhaust (medium or high efficiency furnaces)
- A minimum of at least 6' (2 m) from driveways, oil fill pipes, gas meters, or garbage containers
- At least 18" (457 mm) above the ground, or above the depth of expected snow accumulation
- At least 3' (1 m) from the corner of the building
- Do not locate in a garage, attic or crawl space

### Exhaust Weatherhood Requirements

- At least 6' (2 m) from the ventilation air intake
- At least 18" (457 mm) above ground or above the depth of expected snow accumulation
- At least 3' (1 m) away from the corner of the building
- Not near a gas meter, electric meter or a walkway where fog or ice could create a hazard
- Not into a garage, workshop or other unheated space

When installing the weatherhood, its outside perimeter **must** be sealed with exterior caulking.

## ⚠ ATTENTION

Local codes may require greater distances for exhaust and intake.

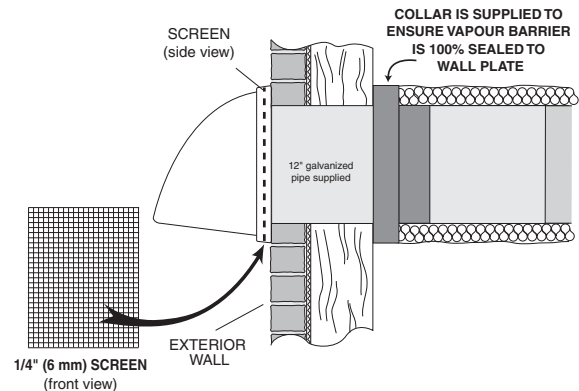
### Weatherhoods

Fixed covered weatherhoods have a built-in bird screen with a 1/4" (6mm) mesh to prevent foreign objects from entering the ductwork.

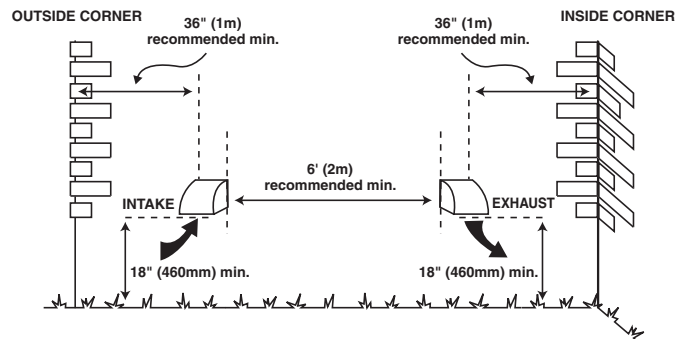
5" (125 mm) Part No.22025

6" (150 mm) Part No. 22026

### Weatherhood Installation



1. Thermal Collar slides over galvanized sleeve of Weatherhood.
2. Fasten Thermal Collar to Belt.
3. Slide the Insulated Flexible Ducting over the Weatherhood's galvanized sleeve and fasten it to the Thermal Collar.
4. Hood is hinged to allow for easy access for cleaning of bird screen.



## ⚠ CAUTION

Weatherhood recommended - requires a minimum of 6' ( 2 m) separation and a minimum of 18" (460mm) above the ground, or above the depth of expected snow accumulation.

## Installation of the Main Control

**Premium Series Controls** may be installed onto a flush mounted 2" x 4" electrical switch box or it may be surface mounted onto a wall.

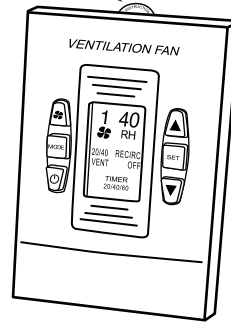
Only 1 master control should be installed to a ventilation system (the Face Plate on this illustration may not be exactly the same as yours).

1. Remove the *Operating Instructions Card* from the top of the Control (Figure A).
2. Separate the *Face Plate* from the *Back Plate* by firmly pulling apart (Figure B). Be careful not to damage Face Plate Contact Pins.
3. Place the *Back Plate* of the control in the desired location on the wall and pencil mark the wall in the center of the *Wire Opening*, *Top Screw Hole* and *Bottom Screw Hole* (Figure C).
4. Remove the *Back Plate* and drill a 3/8" opening in the wall to allow for the *Wire Opening* and a 1/8" hole for the *Wall Anchors* for the top and bottom screw holes (Figure D).
5. Pull 3/20 wire through the opening in the wall and the *Wire Opening* of the *Back Plate* (Figure C).
6. Connect Red, Green and Yellow to the *Wiring Terminals* located on the *Back Plate* (Figure C).
7. Secure a single wire to the *Wire Retainer* located on the *Back Plate* (Figure C).
8. Attach the *Back Plate* to the wall using the 2 supplied screws and anchors.
9. Attach the *Face Plate* to the *Back Plate* (Figure B). Note: Be careful to correctly align the *Face Plate* to avoid damaging the *Face Plate Contact Pins*.
10. Insert the *Operating Instructions Card* into the control (Figure A).
11. Connect the 3/20 wire to the *Terminal Block* located on ventilator (Figure E).

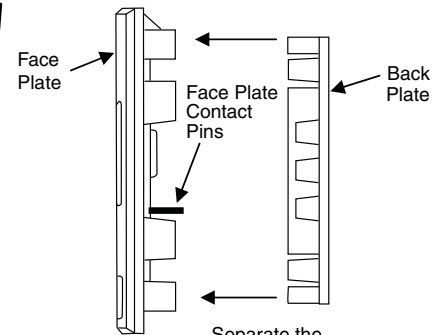
## ⚠ ATTENTION

Pay special attention not to damage the **Contact Pins** when attaching and detaching the **Face Plate**. (Figure B)

Operating Instructions Card

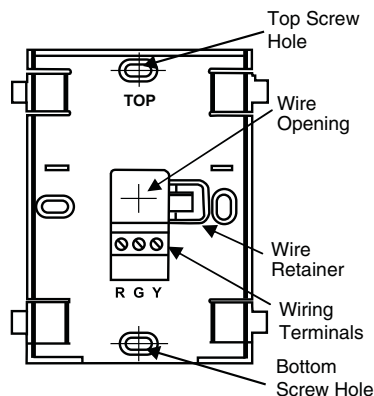


**Figure A - Face Plate**  
(Illustration of Face Plate may vary from actual control)

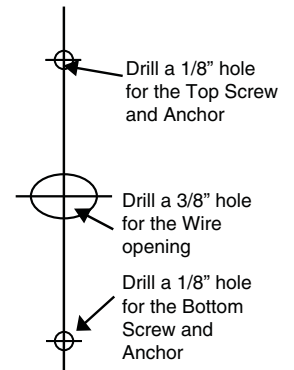


**Figure B**  
Side View

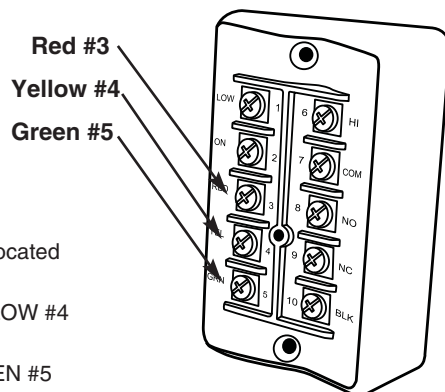
Separate the Face Plate from the Back Plate.



**Figure C**  
Front View of Back Plate



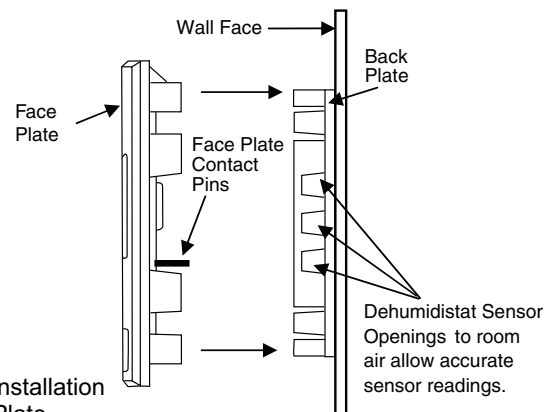
**Figure D**  
Drill holes in wall



**Figure E**

Terminal Block located on ventilator

- Yellow to YELLOW #4
  - Red to RED #3
  - Green to GREEN #5
- Use 3/20 wire



**Figure F**  
Correct Installation of Back Plate

Dehumidistat Sensor Openings to room air allow accurate sensor readings.

**Operating your DET-II 20/40/60 Minute Fan Timer**

Press and release the *Select Button* to activate a 20, 40 or 60 minute high speed override cycle. The *High Speed Status Light* will illuminate and the unit will run on high speed ventilation for the selected time.

The *High Speed Status Light* will dim after 10 seconds of run time.

The *High Speed Status Light* will flash during the last 5 minutes of the cycle.

All timers connected to the unit will illuminate for the duration of the override when the *Select Button* is pressed.

**Lockout Mode**

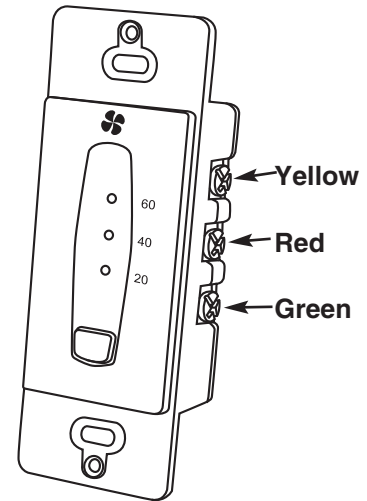
Lockout Mode is useful if you wish to disable the timers.

The timer can be set to lockout mode by pressing and holding the *Select Button* for five seconds. After five seconds, the *High Speed Status Light* will flash; release the *Select Button*. The timer is now in lockout mode. If the *Select Button* is pressed during lockout mode the *High Speed Status Light* will momentarily illuminate but no override will be initiated.

If lockout mode is initiated when the timer is activated, the timer will continue its timed sequence but will not allow any further overrides to be initiated. Lockout mode can be unlocked by pressing and holding the *Select Button* for five seconds. After five seconds the *High Speed Status Light* will stop flashing. Release the *Select Button* and the timer will now operate normally.

**High Speed Status Lights**

**Select Button**  
initiates high speed ventilation for 20, 40 or 60 minutes.



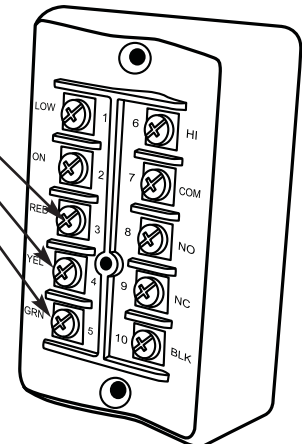
**NOTE ABOUT TIMERS**

- Timers mount in standard 2" x 4" electrical boxes.
- Wire multiple timers individually back to the unit.
- Use 3/20 low voltage wire

Red #3  
Yellow #4  
Green #5

**Terminal Block Connections**

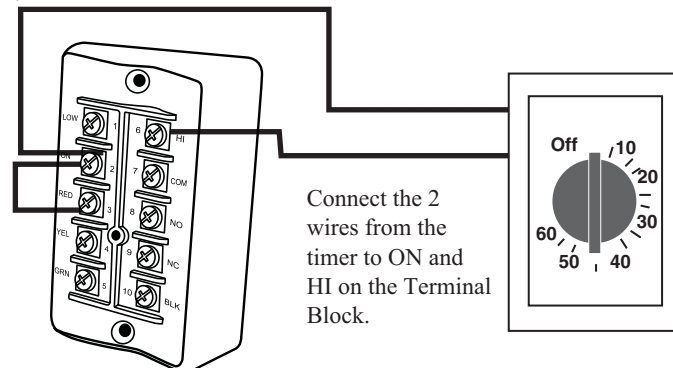
(from Timer to Terminal Block)  
Yellow on timer to YELLOW #4  
Red on timer to RED #3  
Green on timer to GREEN #5



**Installation of Mechanical Timers Part # 28998**

The Mechanical timer is a 2 wire "dry contact" timer. A jumper wire must be connected between ON and RED. Connect the 2 timers wires to ON and HI. Refer to illustration.

2 wire timers require a jumper wire between ON and RED on the terminal block.



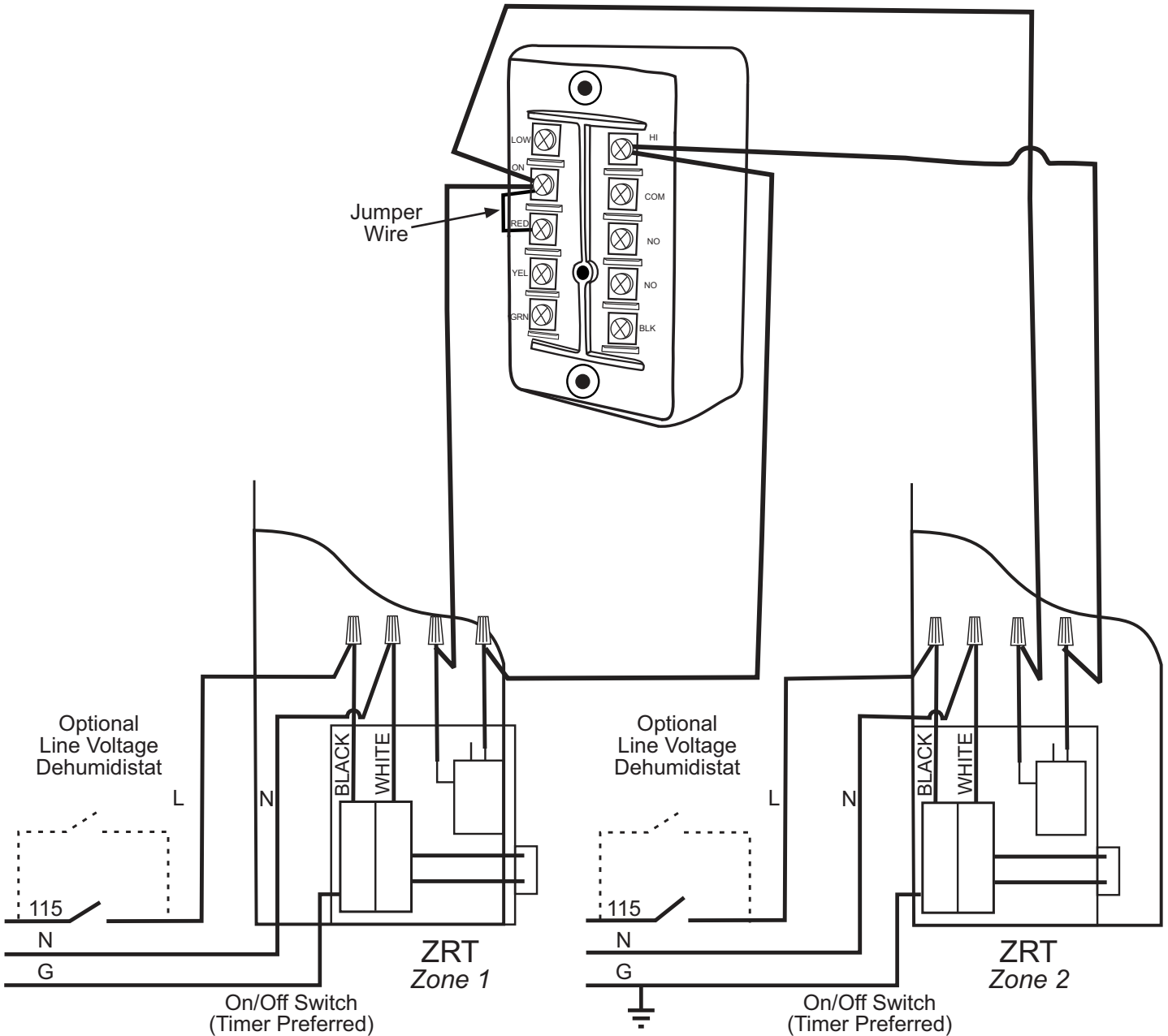
Connect the 2 wires from the timer to ON and HI on the Terminal Block.



# INSTALLATION OF ZRT

## Zone Register Terminal

Roller switches on the ZRTs are “Dry Contacts”. Connect the two red roller switch wires to the **ON** and **HI** terminals. Connect a jumper wire between the ON and RED terminals. (Refer to Illustration.)



ZRT Zone Register Terminals allow high speed ventilation in areas where they are installed (bathroom, kitchen, laundry, etc.).

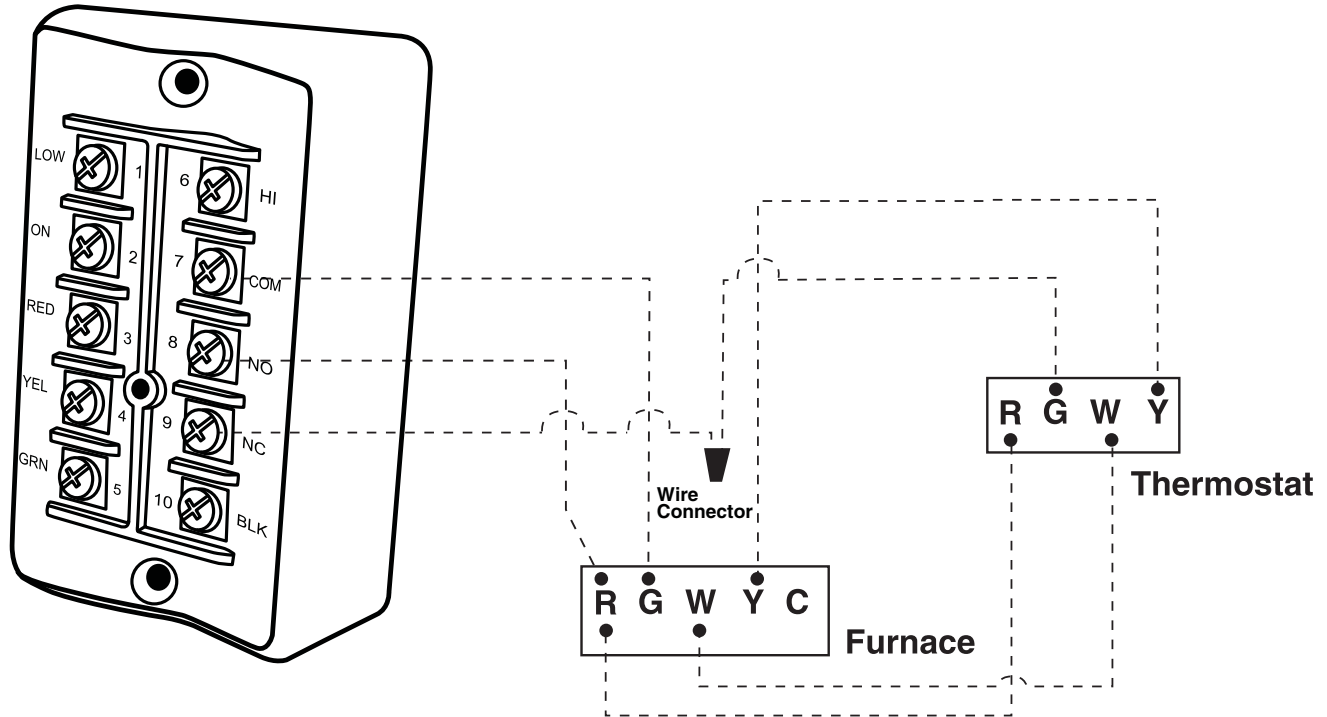
## Interlocking the HRV/ERV to an Air handler/Furnace Blower

Connecting the HRV/ERV as illustrated will ensure the Air Handler/Furnace Blower Motor is operating whenever the HRV/ERV is ventilating.

The HRV/ERV must be interlocked to the Furnace/Air Handler with a Simplified Installation (Return/Return Installation) and should be interlocked with a Partially Dedicated Installation.

## ⚠ CAUTION

Consideration must be given to competing airflows when connecting the HRV/ERV in conjunction with an Air Handler/Furnace Blower system.



## Dry Contacts

Dry contact controls may be connected to initiate Hi/Low fan speed operation.

A Jumper must be in place between 2 (ON) and 3 (RED) to activate the dry contacts and timers.

### Low Speed

Low Speed is initiated through a dry contact between 2 (ON) and 1 (LOW).

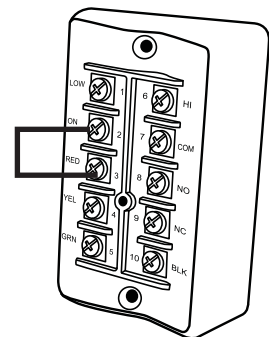
### High Speed

High Speed is initiated through a dry contact between 2 (ON) and 6 (HI).

### Dehumidistat

A dry contact for a remote dehumidistat is connected between 2 (ON) and 10 (BLK).

A Jumper must be in place between 2 (ON) and 3 (RED) to activate the dry contacts and timers.



## Pitot Tube Air Flow Balancing

It is necessary to have balanced air flows in an HRV/ERV. The volume of air brought in from the outside must equal the volume of air exhausted by the unit. If the air flows are not properly balanced, then;

- The HRV/ERV may not operate at its maximum efficiency
- A negative or positive air pressure may occur in the house
- The unit may not defrost properly
- Failure to balance HRV/ERV properly may void warranty

**Excessive positive pressure** may drive moist indoor air into the external walls of the building where it may condense (in cold weather) and degrade structural components. May also cause key holes to freeze up.

**Excessive negative pressure** may have several undesirable effects. In some geographic locations, soil gases such as methane and radon gas may be drawn into the home through basement/ground contact areas. Excessive negative pressure may also cause the backdrafting of vented combustion equipment.

**Read the Application Warning at the beginning of this manual!**

### Prior to balancing, ensure that:

1. All sealing of the ductwork system has been completed.
2. All of the HRV/ERV's components are in place and functioning properly.
3. Balancing dampers are fully open.
4. Unit is on HIGH speed.
5. Air flows in branch lines to specific areas of the house should be adjusted first prior to balancing the unit. A smoke pencil used at the grilles is a good indicator of each branch line's relative air flow.
6. After taking readings of both the stale air to the HRV/ERV duct and fresh air to the house duct, the duct with the lower CFM ([L/s] velocity) reading should be left alone, while the duct with the higher reading should be dampered back to match the lower reading.
7. Return unit to appropriate fan speed for normal operation

### Balancing Procedure

The following is a method of field balancing an HRV/ERV using a Pitot tube, advantageous in situations when flow stations are not installed in the ductwork. Procedure should be performed with the HRV/ERV on high speed.

The first step is to operate **all** mechanical systems on high speed, which have an influence on the ventilation system, i.e. the HRV/ERV itself and the forced air furnace or air handler if applicable. This will provide the maximum pressure that the HRV/ERV will need to overcome, and allow for a more accurate balance of the unit.

Drill a small hole in the duct (about 3/16"), three feet downstream of any elbows or bends, and one foot upstream of any elbows or bends. These are recommended distances but the actual installation may limit the amount of straight duct.

The Pitot tube should be connected to a magnehelic gauge or other manometer capable of reading from 0 to 0.25 in. (0-62 Pa) of water, preferably to 3 digits of resolution. The tube coming out of the top of the pitot is connected to the high pressure side of the gauge. The tube coming out of the side of the pitot is connected to the low pressure or reference side of the gauge.

Insert the Pitot tube into the duct; pointing the tip into the airflow.

For general balancing it is sufficient to move the pitot tube around in the duct and take an average or typical reading. Repeat this procedure in the other (supply or return) duct. Determine which duct has the highest airflow (highest reading on the gauge). Then damper that airflow back to match the lower reading from the other duct. The flows should now be balanced. Actual airflow can be determined from the gauge reading. The value read on the gauge is called the velocity pressure. The Pitot tube comes with a chart that will give the air flow velocity based on the velocity pressure indicated by the gauge. This velocity will be in either feet per minute or meters per second. To determine the actual airflow, the velocity is multiplied by the cross sectional area of the duct being measured.

This is an example for determining the airflow in a 6" duct.

The Pitot tube reading was 0.025 inches of water.

From the chart, this is 640 feet per minute.

$$\begin{aligned} \text{The 6" duct has a cross sectional area of} &= [3.14 \times (6" \div 12)^2] \div 4 \\ &= 0.2 \text{ square feet} \end{aligned}$$

The airflow is then:

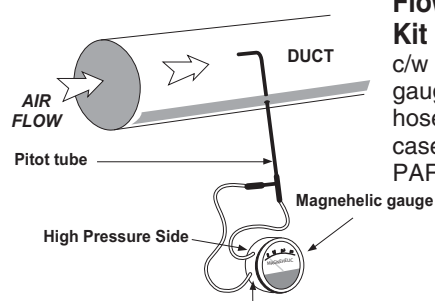
$$640 \text{ ft./min.} \times 0.2 \text{ square feet} = 128 \text{ cfm}$$

For your convenience, the cross sectional area of some common round duct is listed below:

| DUCT DIAM. (inches) | CROSS SECTION AREA (sq. ft.) |
|---------------------|------------------------------|
| 5                   | 0.14                         |
| 6                   | 0.20                         |
| 7                   | 0.27                         |

The accuracy of the air flow reading will be affected by how close to any elbows or bends the readings are taken. Accuracy can be increased by taking an average of multiple readings as outlined in the literature supplied with the Pitot tube.

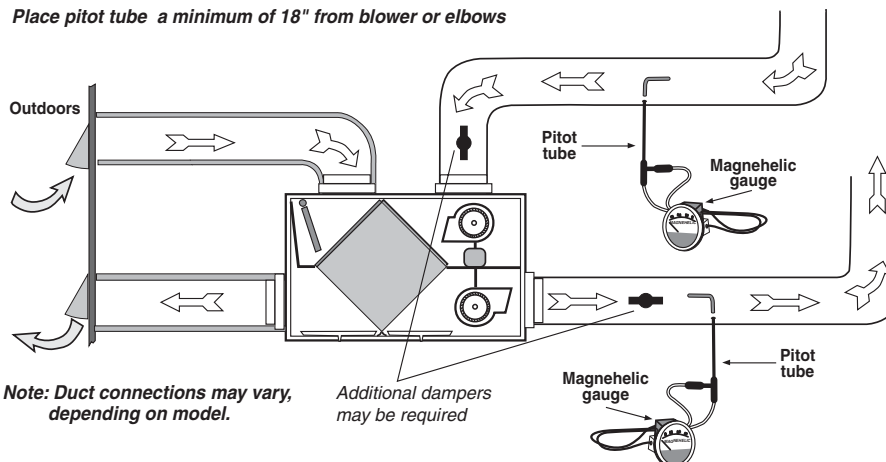
### Pitot tube and gauge



### Pitot Tube Air Flow Balancing Kit

c/w magnehelic gauge, Pitot tube, hose and carry case.  
PART NO. 97015

*Place pitot tube a minimum of 18" from blower or elbows*

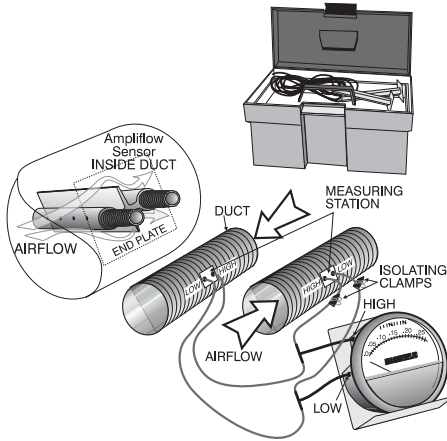


# AIR FLOW MEASURING KIT

The American ALDES airflow measuring kit is designed to measure airflow accurately in ducting. Utilizing the Ampliflow sensor by Nailor-Hart Industries, it is three times as sensitive as a Pitot tube, allowing the measurement of very low velocities. The design also averages the variations in velocity pressure across the diameter of the duct, to provide a mean airflow reading.

## The Airflow Measuring Kit is comprised of the following items:

- Ampliflow sensors for 6" and 8" ducting.
- Dwyer Magnehelic pressure gauge, 0-0.25 in. w.g. range.
- Flexible tubing to connect pressure gauge to sensors
- Airflow Table to convert pressure readings to airflow in cfm.



## FEATURES:

### Ampliflow® sensor\*:

- Multi-point readings eliminate need for pitot tube traverses.
- Adaptable to round, oval or rectangular duct.
- Accurate low velocity readings—provides 3 times the pressure reading of a Pitot tube at the same velocity.

Dwyer Magnehelic®—an industry standard in differential pressure measurement.

- Accuracy of measurement: Plus or minus 4% of full scale at 70 F.
- Can accept overpressure up to 15 PSI.
- Comes with mounting stand, 1/8 tubing connectors, probe for static pressure measurements, plastic storage case.
- Dual scale readings for pressure (in. w.g.) and velocity (FPM) when used with a Pitot tube.

## BALANCING PROCEDURE

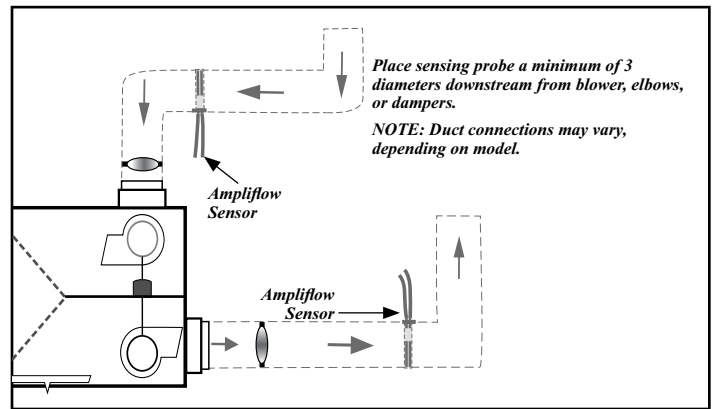
Prior to balancing, make sure that:

- All sealing of the ductwork system has been completed.
- All of the HRV's components are in place and functioning properly.
- Balancing dampers are fully open.
- Adjustment of airflows at the individual grilles should be done prior to balancing the total supply and exhaust airflows. A smoke pencil maybe used to indicate relative airflows at the supply or exhaust grilles.

1. Set the pressure gauge on a level surface, near the duct location where the airflow is to be measured. Check to see it reads zero, with no airflow across the sensor. If not, use a small screwdriver to adjust the meter. See the Dwyer instructions packaged with the Magnehelic gauge.
2. Insert the Ampliflow sensor into a straight section of duct, with the arrow pointing in the direction of the airflow. To avoid air flow turbulence and incorrect readings, the flow sensor should be located at least three (3) diameters

downstream from elbow, balancing damper, etc. If flexible ducting is used, it may be advisable to insert the Ampliflow sensor into a short collar of metal duct.

3. Be sure to connect the low and high pressure taps on the gauge to the corresponding taps on the Ampliflow sensors.
4. Turn the unit to HIGH speed. (Note: it may be necessary to reduce the speed if the pressure gauge is driven off scale. No damage will result, the gauge is capable of 15 PSI, much higher than the maximum scale reading.)
5. Find the airflow from the column matching the duct diameter and the pressure reading on the upper scale of the gauge.
6. After taking readings of both the stale air to the HRV/ERV duct and the fresh air to the house duct, the duct with the lower cfm should be left alone, while the duct with the higher reading should be dampered back to match the lower reading.
7. Remove the flow sensor from the duct and seal the holes with approved duct tape. The sensor may be left in place to check airflows later.
8. Return the unit to appropriate fan speed for normal operation. Note: Airflows may be measured in smaller diameter ducts by taping over the sensor holes on the tubing that are exposed outside the duct. Failure to close them will result in low readings.

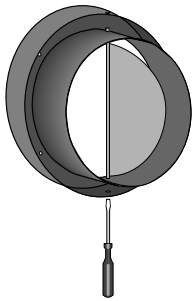


AIRFLOW TABLE FOR AMPLIFLOW SENSOR

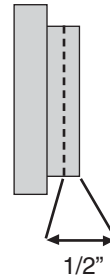
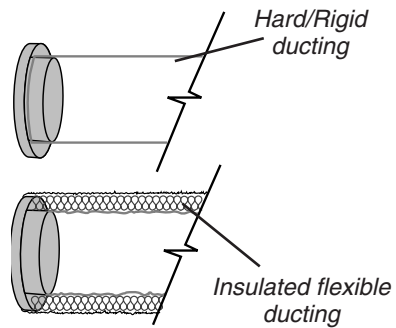
| Delta P In. W.G. | Velocity FPM | CFM 4" Diam. | CFM 5" Diam. | CFM 6" Diam. | CFM 7" Diam. | Delta P In. W.G. | Velocity FPM | CFM 4" Diam. | CFM 5" Diam. | CFM 6" Diam. | CFM 7" Diam. |
|------------------|--------------|--------------|--------------|--------------|--------------|------------------|--------------|--------------|--------------|--------------|--------------|
| 0.005            | 150          | 13           | 20           | 29           | 40           | 0.135            | 779          | 68           | 106          | 153          | 208          |
| 0.010            | 212          | 19           | 29           | 42           | 57           | 0.140            | 794          | 69           | 108          | 156          | 212          |
| 0.015            | 260          | 23           | 35           | 51           | 69           | 0.145            | 808          | 70           | 110          | 159          | 216          |
| 0.020            | 300          | 26           | 41           | 59           | 80           | 0.150            | 822          | 72           | 112          | 161          | 220          |
| 0.025            | 335          | 29           | 46           | 66           | 90           | 0.155            | 835          | 73           | 114          | 164          | 223          |
| 0.030            | 367          | 32           | 50           | 72           | 98           | 0.160            | 849          | 74           | 116          | 167          | 227          |
| 0.035            | 397          | 35           | 54           | 78           | 106          | 0.165            | 862          | 75           | 117          | 169          | 230          |
| 0.040            | 424          | 37           | 58           | 83           | 113          | 0.170            | 875          | 76           | 119          | 172          | 234          |
| 0.045            | 450          | 39           | 61           | 88           | 120          | 0.175            | 887          | 77           | 121          | 174          | 237          |
| 0.050            | 474          | 41           | 65           | 93           | 127          | 0.180            | 900          | 79           | 123          | 177          | 241          |
| 0.055            | 497          | 43           | 68           | 98           | 133          | 0.185            | 912          | 80           | 124          | 179          | 244          |
| 0.060            | 520          | 45           | 71           | 102          | 139          | 0.190            | 925          | 81           | 126          | 182          | 247          |
| 0.065            | 541          | 47           | 74           | 106          | 145          | 0.195            | 937          | 82           | 128          | 184          | 250          |
| 0.070            | 561          | 49           | 77           | 110          | 150          | 0.200            | 949          | 83           | 129          | 186          | 254          |
| 0.075            | 581          | 51           | 79           | 114          | 155          | 0.205            | 960          | 84           | 131          | 189          | 257          |
| 0.080            | 600          | 52           | 82           | 118          | 160          | 0.210            | 972          | 85           | 133          | 191          | 260          |
| 0.085            | 618          | 54           | 84           | 121          | 165          | 0.215            | 984          | 86           | 134          | 193          | 263          |
| 0.090            | 636          | 56           | 87           | 125          | 170          | 0.220            | 995          | 87           | 136          | 195          | 266          |
| 0.095            | 654          | 57           | 89           | 128          | 175          | 0.225            | 1006         | 88           | 137          | 198          | 269          |
| 0.100            | 671          | 59           | 91           | 132          | 179          | 0.230            | 1017         | 89           | 139          | 200          | 272          |
| 0.105            | 687          | 60           | 94           | 135          | 184          | 0.235            | 1028         | 90           | 140          | 202          | 275          |
| 0.110            | 704          | 61           | 96           | 138          | 188          | 0.240            | 1039         | 91           | 142          | 204          | 278          |
| 0.115            | 719          | 63           | 98           | 141          | 192          | 0.245            | 1050         | 92           | 143          | 206          | 281          |
| 0.120            | 735          | 64           | 100          | 144          | 196          | 0.250            | 1061         | 93           | 145          | 208          | 283          |
| 0.125            | 750          | 65           | 102          | 147          | 200          |                  |              |              |              |              |              |
| 0.130            | 765          | 67           | 104          | 150          | 204          |                  |              |              |              |              |              |

\*Ampliflow® is a Registered Trademark of Nailor-Hart Industries. Magnehelic® is a Registered Trademark of Dwyer Instruments, Inc.

## Balancing Collar Instructions



Push and turn with slotted screwdriver. Damper automatically locks when pressure is released.



When connecting ductwork to the collar, take note where screws are located. Screws should be located no further than 1/2" from outside edge of collar, so as not to impede operation of the damper.

\*Balancing Collar is not available on all models.

### NOTE

***Installations where the HRV/ERV is ducted directly to the return of a furnace may require additional dampening on the fresh air to building duct. This is due to the high return static pressures found in some furnace installations.***

## Maintenance Routine for HRV/ERV

### 1. Inspect Exterior Hoods at least once a month.

Make sure exhaust and fresh air supply hoods are not blocked or restricted by leaves, grass, or snow. In winter, it is especially important to make sure snow is not blocking the hoods or that frost has not built up on the wire mesh (bird screen).

**WARNING:** Blockage of hoods may cause an imbalance.

### 2. Clean Air Filters (clean twice a year)

The standard filters equipped with your HRV are removable and washable.

- simply open access door and slide core out
- remove filter clips if present
- once clips are removed filters can be taken off the core to be rinsed with water or a combination of mild soap and water. Do not clean in the dishwasher
- to re-assemble, place clean filter(s) (wet or dry) back into their positions against the core and return clips to their original position
- slide core back into its original position

### 3. Clean Core Twice a Year

#### **ATTENTION**

- Vacuum the ERV core or rinse with cold water
- Do not use cleaning solutions for the HRV Core
- Soak and rinse the HRV core in warm soapy water
- Do not use bleach or chlorine
- Do not use a pressure washer on the HRV or ERV core
- Do not place the HRV or ERV core in a dishwasher

- open access door.
- carefully grip ends of core and pull evenly outward. Core may be snug, but will slide out of the channel
- once removed from the cabinet remove filters
- ERV core** - Vacuum the core or rinse with cold water (DO NOT USE SOAP, DISHWASHER OR A PRESSURE WASHER.)  
**HRV core** - Soak in warm soapy water and rinse
- install the clean filters
- install clean core

**Note:** Core installation label on the outer end of the core.

#### To install the clean core:

- first mount the bottom flange of the core guide into the bottom H channel approximately 1/4" (6mm)
- mount the left or right side flange of the core guide approximately 1/4" (6mm) followed by the other side
- mount the top flange of the core guide into the top H channel approximately 1/4" (6mm).
- with all four corners in place and the core straight and even, push hard in the center of the core until the core stops on the back of the cabinet.

**NOTE:** Core will appear to stick out from cabinet approximately 1/8" (3mm). This is designed this way so that the access door will fit tight against the core.

### 4. Motors - Maintenance Free

### 5. Drain (condensate) Line - Clean once a year

Inspect drain line, drain spout and "P" trap for blockage, mold or kinks. Flush with warm soapy water and replace if worn, bent or unable to clean.

### 6. Clean Duct Work if Required

The duct work running to and from the HRV may accumulate dirt. Wipe and vacuum the duct once every year. You may wish to contact a Heating/Ventilation company to do this.

### 7. General Maintenance - Twice a Year

Wipe down the inside of the cabinet with a damp cloth to remove dirt, bugs and debris that may be present.

### 8. Cleaning the Fans

Fans may accumulate dirt causing an imbalance and/or excessive vibration of the HRV. A reduction in the air flow may also occur. In new construction this may result within the first year due to heavy dust and may occur periodically after that over time depending on the outdoor conditions.

- unplug the HRV and open the service door
- remove the core
- remove ducting (metal and/or flexible insulated type) from the red and/or blue ports which are connected immediately in-line with the fan assembly
- use a small brush, such as an old toothbrush or pipe cleaner, and insert first
  - through the large opening of the fan assembly and then
  - through the smaller opening in the end of the fan assembly.
- scrub individual fan blades until clean. Avoid moving or damaging balancing flat weight, clip is usually found on one or more of the fan blades
- vacuum and wipe
- reassemble making sure ducting is reattached firmly and insulation and moisture barrier are sealed and taped

#### **WARNING**



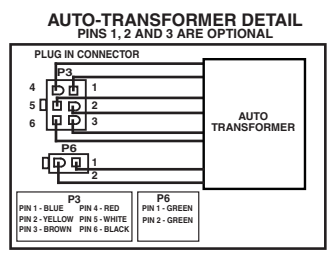
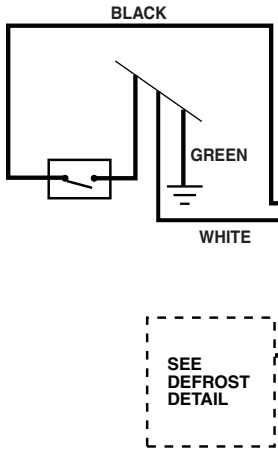
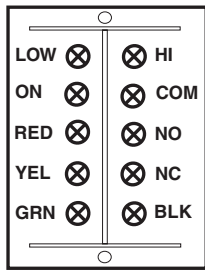
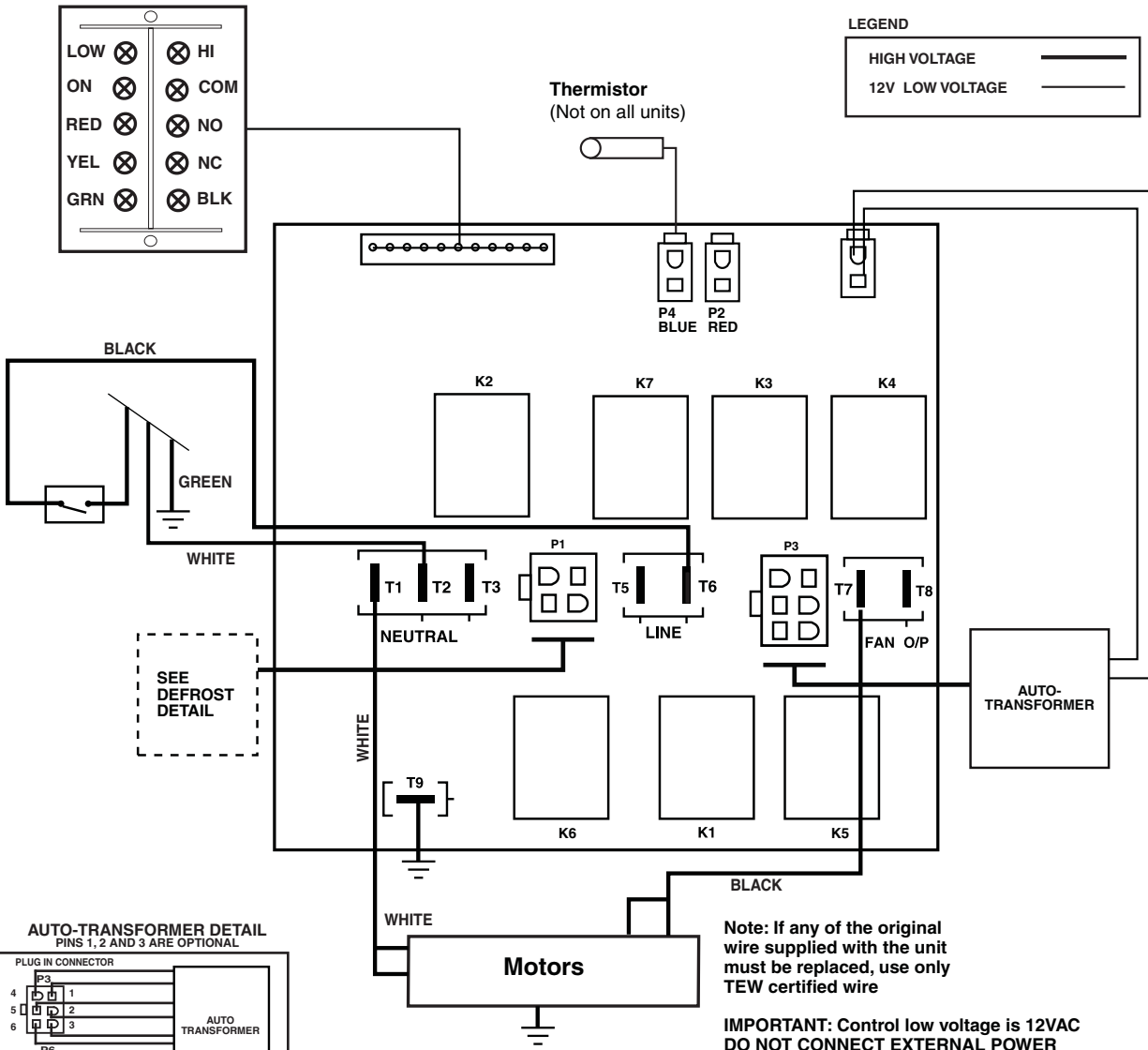
**Electric shock hazard. Can cause injury or death. Before attempting to perform any service or maintenance, turn the electrical power unit OFF at disconnect switch(es). Unit may have multiple power supplies.**

*Before attempting this task, thought should be given to having a qualified service technician complete the service work.*

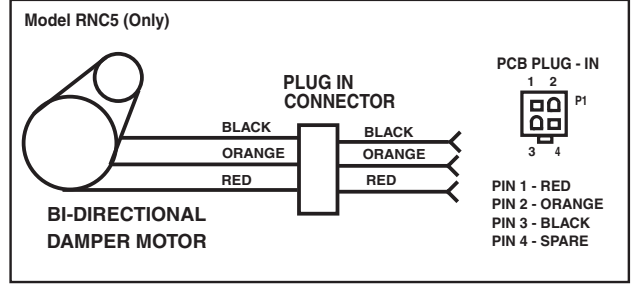
## Troubleshooting your HRV/ERV System

| SYMPTOM  | CAUSE   | SOLUTION  |
|--|---|---|
| Poor Air Flows   | <ul style="list-style-type: none"> <li>• 1/4" (6 mm) mesh on the outside hoods is plugged</li> <li>• filters plugged</li> <li>• core obstructed</li> <li>• house grilles closed or blocked</li> <li>• dampers are closed if installed</li> <li>• poor power supply at site</li> <li>• ductwork is restricting HRV/ERV</li> <li>• improper speed control setting</li> <li>• HRV/ERV airflow improperly balanced</li> </ul>                                     | <ul style="list-style-type: none"> <li>• clean exterior hoods or vents</li> <li>• remove and clean filter</li> <li>• remove and clean core</li> <li>• check and open grilles</li> <li>• open and adjust dampers</li> <li>• have electrician check supply voltage at house</li> <li>• check duct installation</li> <li>• increase the speed of the HRV/ERV</li> <li>• have contractor balance HRV/ERV</li> </ul>   |
| Supply air feels cold  | <ul style="list-style-type: none"> <li>• poor location of supply grilles, the airflow may irritate the occupant</li> <li>• outdoor temperature extremely cold</li> </ul>  | <ul style="list-style-type: none"> <li>• locate the grilles high on the walls or under the baseboards, install ceiling mounted diffuser or grilles so as not to directly spill the supply air on the occupant (eg. over a sofa)</li> <li>• turn down the HRV/ERV supply speed. A small duct heater (1kw) could be used to temper the supply air</li> <li>• placement of furniture or closed doors is restricting the movement of air in the home</li> <li>• if supply air is ducted into furnace return, the furnace fan may need to run continuously to distribute ventilation air comfortably</li> </ul>  |
| Dehumidistat is not Operating  | <ul style="list-style-type: none"> <li>• outdoor temperature is above 15°C (59°F)</li> <li>• improper low voltage connection</li> <li>• external low voltage is shorted out by a staple or nail</li> <li>• check dehumidistat setting it may be on OFF</li> </ul>   | <ul style="list-style-type: none"> <li>• dehumidistat is functioning normally (see Auto Dehumidistat Disable in this manual)</li> <li>• check that the correct terminals have been used</li> <li>• check external wiring for a short</li> <li>• set the dehumidistat at the desired setting</li> </ul>  |
| Humidity Levels are too High<br>Condensation is appearing on the windows | <ul style="list-style-type: none"> <li>• dehumidistat is set too high</li> <li>• HRV/ERV is undersized to handle a hot tub, indoor pool, etc.</li> <li>• lifestyle of the occupants</li> <li>• moisture coming into the home from an unvented or unheated crawl space</li> <li>• moisture is remaining in the washroom and kitchen areas</li> <li>• condensation seems to form in the spring and fall</li> <li>• HRV/ERV is set at too low a speed</li> </ul> | <ul style="list-style-type: none"> <li>• set dehumidistat lower</li> <li>• cover pools, hot tubs when they are not in use</li> <li>• avoid hanging clothes to dry, storing wood and venting clothes dryer inside. Heating wood may have to be moved outside</li> <li>• vent crawl space and place a vapor barrier on the floor of the crawl space</li> <li>• ducts from the washroom should be sized to remove moist air as effectively as possible, use of a bathroom fan for short periods will remove additional moisture</li> <li>• on humid days, as the seasons change, some condensation may appear but the homes air quality will remain high with some HRV/ERV use</li> <li>• increase speed of the HRV/ERV</li> </ul> |
| Humidity Levels are too Low  | <ul style="list-style-type: none"> <li>• dehumidistat control set too low</li> <li>• blower speed of HRV/ERV is too high</li> <li>• lifestyle of occupants</li> <li>• HRV/ERV air flows may be improperly balanced</li> </ul>   | <ul style="list-style-type: none"> <li>• set dehumidistat higher</li> <li>• decrease HRV/ERV blower speed</li> <li>• humidity may have to be added through the use of humidifiers</li> <li>• have a contractor balance HRV/ERV airflows</li> </ul>  |
| HRV/ERV and / or Ducts Frosting up                                       | <ul style="list-style-type: none"> <li>• HRV/ERV air flows are improperly balanced</li> <li>• malfunction of the HRV/ERV defrost system</li> </ul>  | <ul style="list-style-type: none"> <li>• Note: minimal frost build-up is expected on cores before unit initiates defrost cycle functions</li> <li>• have HVAC contractor balance the HRV/ERV</li> <li>• ensure damper defrost is operating during self-test</li> </ul>  |
| Condensation or Ice Build Up in Insulated Duct to the Outside            | <ul style="list-style-type: none"> <li>• incomplete vapor barrier around insulated duct</li> <li>• a hole or tear in outer duct covering</li> </ul>   | <ul style="list-style-type: none"> <li>• tape and seal all joints</li> <li>• tape any holes or tears made in the outer duct covering</li> <li>• ensure that the vapor barrier is completely sealed</li> </ul>   |
| Water in the bottom of the HRV/ERV                                       | <ul style="list-style-type: none"> <li>• drain pans plugged</li> <li>• improper connection of HRV/ERVs drain lines</li> <li>• HRV/ERV is not level</li> <li>• drain lines are obstructed</li> <li>• HRV/ERV heat exchange core is not properly installed</li> </ul>   | <ul style="list-style-type: none"> <li>• ensure O-Ring on drain nozzle sits properly</li> <li>• look for kinks in line</li> <li>• check water drain connections</li> <li>• make sure water drains properly from pan</li> </ul>  |

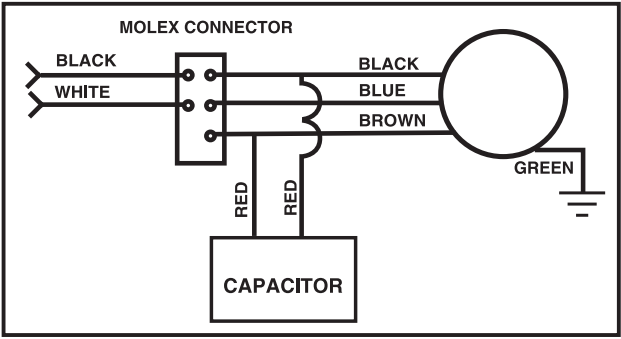
**CAUTION: ELECTRICAL CONTROL PANEL, SERVICE BY ELECTRICIAN ONLY**



**DEFROST DETAILS**

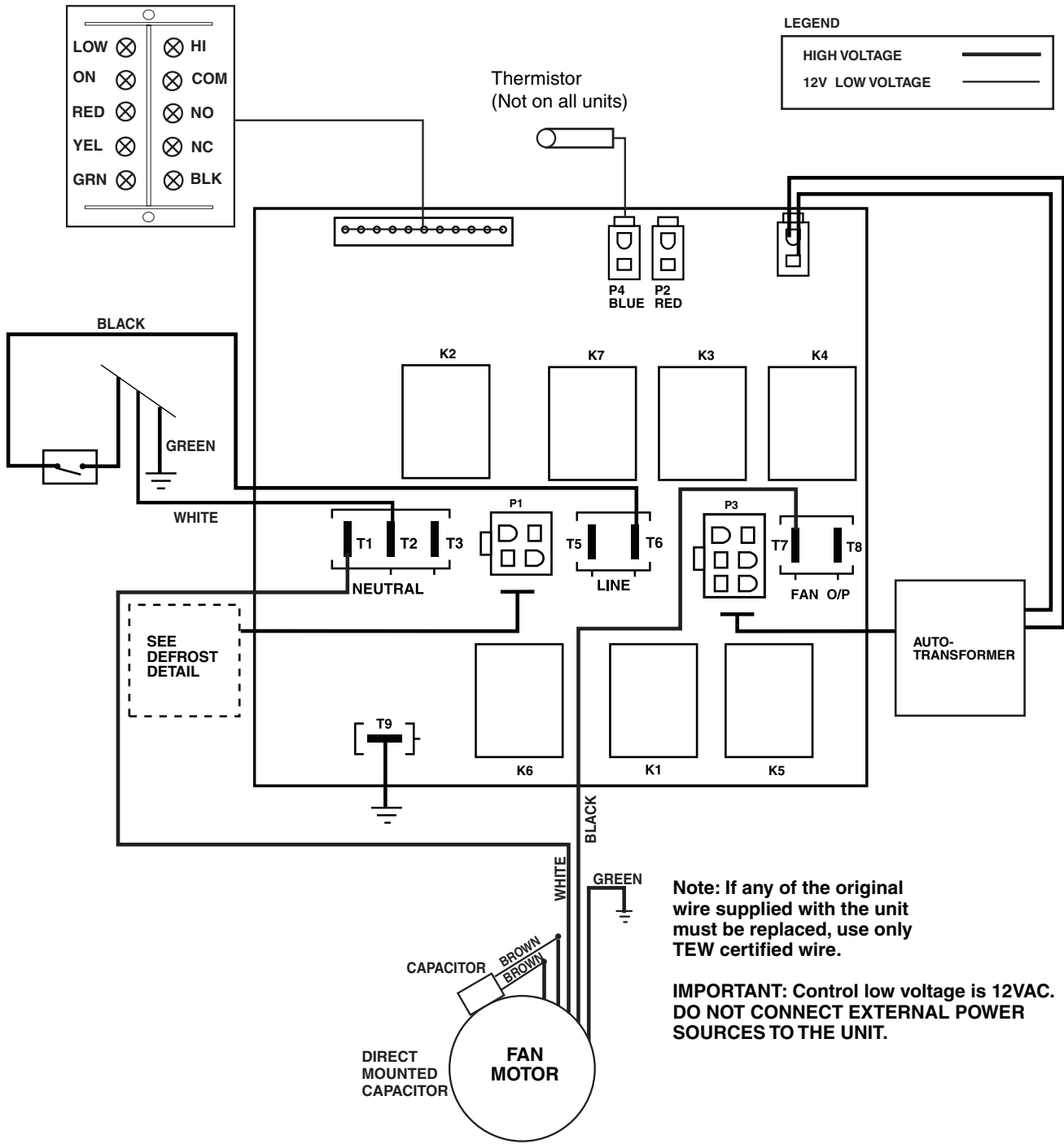


**FAN MOTOR DETAILS**





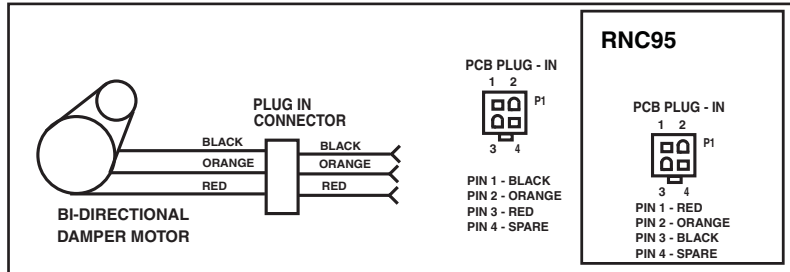
**CAUTION: ELECTRICAL CONTROL PANEL, SERVICE BY ELECTRICIAN ONLY**



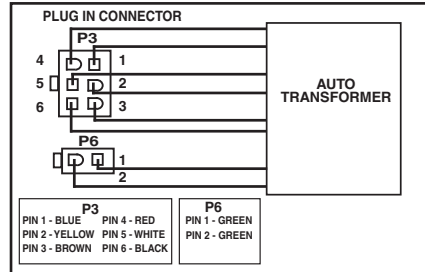
**Note:** If any of the original wire supplied with the unit must be replaced, use only TEW certified wire.

**IMPORTANT:** Control low voltage is 12VAC. DO NOT CONNECT EXTERNAL POWER SOURCES TO THE UNIT.

**DEFROST DETAILS**



**AUTO-TRANSFORMER DETAIL**





## HEAT AND ENERGY RECOVERY VENTILATOR WARRANTY

◆ TWO YEAR LIMITED WARRANTY ◆

◆ 15 YEAR HRV CORE WARRANTY and 5 YEAR ERV CORE WARRANTY ◆

**AMERICAN ALDES VENTILATION CORPORATION** warrants, to the original purchaser of this HRV or ERV unit, that it is free from manufacturing defects.

This WARRANTY is personal to **AMERICAN ALDES VENTILATION CORP.**, and is in effect from the date of the original purchase, for a period of two years, save and except that a 15 YEAR WARRANTY is given to the original HRV core and a 5 YEAR WARRANTY on the original ERV core, should it develop a condensation leak or become perforated due to corrosion caused by normal use.

### LIMITATIONS OF WARRANTY AND LIABILITY

This warranty does not apply to any **AMERICAN ALDES** product or part which has failed as a result of faulty installation or abuse, incorrect electrical connections or alterations made by others, or use under abnormal operating conditions or misapplication of the product or parts. We will not approve any repair not made by us, or our authorized agent without prior written consent. The foregoing shall constitute our sole and exclusive warranty and our sole and exclusive liability, and is in lieu of any other warranties, whether written, oral, implied or statutory. There are no warranties which extend beyond this warranty document. In no event, whether as a result of breach of contract, or warranty or alleged negligence, defect, incorrect advice or other causes, shall **AMERICAN ALDES VENTILATION CORP.**, become liable for special or consequential damages, including but not limited to, loss of profits or revenue, loss of use of equipment or any other associated equipment, cost of substitute equipment, facilities or services, downtime costs, or claims of customers of purchases for such damages. **AMERICAN ALDES VENTILATION CORP.**, neither assumes or authorizes any person to assume for it, any other liability in connection with the sale of its products or parts. Some jurisdictions do not allow the exclusion or limitation of incidental or consequential damages, so the above limitations and exclusions may not apply.

If the **AMERICAN ALDES VENTILATION CORP.**, unit purchased is not free from manufacturing defects write to:

**AMERICAN ALDES VENTILATION CORPORATION,**  
4521 19<sup>th</sup> Street Court E., Suite 104, Bradenton, FL 34203-3791  
P 941-351-3441 F 941-351-3442

Please include your name address and telephone number and we will provide instructions for the return of defective components, or to find the name of the nearest dealer for repair.

### FACTORY RETURNS

1. Call us to obtain a Return Materials Authorization (RMA) number.  
**AMERICAN ALDES VENTILATION CORP.**, Phone: 941-351-3441.  
Please have the Bill of Sale available for reference. NOTE: Items CAN NOT be returned WITHOUT an RMA number.
2. Clearly print or type the RMA number on the outside of the carton BEFORE shipping the return to us. Items NOT displaying an RMA number may be refused for delivery.
3. All products being returned MUST be shipped prepaid and include a copy of the original Bill of Sale.
4. Product will be replaced/repaired and shipped back to recipient. No credit will be issued.

The cost of labor required to install any replacement part(s) shall be the option of the customer in either of the following ways:

- a. The customer may supply labor at their own expense  
or
- b. If the product was purchased from a dealer, then the dealer will supply labor at cost to the customer

**AMERICAN ALDES VENTILATION CORP.**, reserves the right to replace the entire unit or to refund the original purchase price in lieu of repair.

### WARRANTY VALIDATION

The end user must keep a copy of the Bill of Sale to verify purchase date.



4521 19th Street Court E., Suite 104, Bradenton, FL 34203 USA  
P: 941-351- 3441 - F: 941-351- 3442  
[www.americanaldes.com](http://www.americanaldes.com) ~ E: [info@aldes-us.com](mailto:info@aldes-us.com)

**IAQ**  
VENTILATION  
**HOTLINE**  
**800-255-7749**