

INSTALLER'S & OWNER'S MANUAL

HVAC INSTALLER: PLEASE LEAVE MANUAL FOR HOMEOWNER



Santa Fe

ADVANCE



Designed For Basement and Crawlspace Dehumidification

P/N 4029800 • Serial No. _____ Install Date: _____

Sold by:



Driven by performance. Powered by design.[™] 4201 Lien Rd. Madison, WI 53708 • TOLL-FREE 1-800-533-7533 • www.santa-fe-products.com • sales@thermastor.com

© 2009 Therma-Stor LLC • Manual P/N TS-596 10/09

Table of Contents

Precautions	1
1. Intended Application	2
2. Registrations	2
3. Specifications	3
4. Unit Assembly	3
4.1 Installing Feet	3
4.2 Attaching Drain Hose	3
5. Installation	3
5.1 Location	3
5.2 Electrical Requirements	4
5.3 Condensate (Water) Removal	4
6. Operation	4
6.1 Humidity Control Adjustment	4
6.2 Defrost Cycle	4
6.3 Blower (Fan) Switch	4
7. Maintenance	5
7.1 Air Filter	5
7.2 Cleaning and Replacement	5
7.3 Removing Filters	5
7.4 Installing Filters	5
8. Service	5
8.1 Technical Description	5
8.2 Troubleshooting	6
9. Accessory/Replacement Parts	6
Condensate Pump Kit	7
Duct Kit Assembly.....	9
Warranty	11

Precautions

- Do not operate the unit with a cut or frayed power cord.
- Do not unplug the unit by pulling on the cord. Grasp the plug firmly and pull it out of the wall socket or power receptacle.
- Always use a grounded outlet.
- Never operate electrical equipment near or in standing water.
- Do not stick your fingers or other objects through the safety grills.
- Do not restrict airflow into or out of the unit. This may cause the unit to overheat.
- Unit should never be serviced or cleaned while it is plugged in.
- Do not sit or stand on the unit or use as a shelf or table.
- Before leaving the Santa Fe Advance unattended, ensure children do not have access to the equipment. Do not allow children to play with or near the unit or in its air flow.
- The Santa Fe Advance is designed to be installed indoors only.

Read the installation, operation and maintenance instructions carefully before installing and using this unit. Proper adherence to these instructions is essential to obtain maximum benefit from your Santa Fe dehumidifier.

Read and Save These Instructions

 **WARNING!** — This symbol means important instructions. Failure to heed them can result in serious injury or death.

 **CAUTION!** — This symbol means important instructions. Failure to heed them can result in injury or material property damage.

1. Intended Application

The Santa Fe Advance is intended for installation in crawl spaces or basements that experience short or long-term high humidity conditions; however, the attractively designed unit can be placed in almost any residential setting where dehumidification is desired. Use in non-residential applications and pool areas will void warranty.

The Santa Fe Advance is designed to operate in temperatures between 56° and 95°F. Temperatures outside of these ranges may affect dehumidifier performance.

In order to efficiently control the humidity levels, the area in which the dehumidifier is to be placed must be free of water intrusion or excessive fresh (outside) air infiltration. Before installing the Santa Fe Advance, water intrusion and air infiltration problems should be addressed.

2. Registration

The Santa Fe Advance conforms to UL STD 474 and CSA standard C22.2 No. 92

3. Specifications

Part Number:	4029800		
Blower:	220 CFM @ 0.0" WG		
Power:	710 watts @ 80°F and 60% RH		
Supply Voltage:	115 volt – 1phase – 60 Hz		
Current Draw:	6.7 Amps		
Operating Temp.:	45°F Min., 95°F Max.		
Sized for:	2200 Sq. Ft. - Typical		
Minimum Performance at 80°F and 60% RH			
Water Removal:	90 Pints/Day		
Efficiency:	5.3 Pints/kWhr		
Energy Factor:	2.5 L/kWhr		
Air Filter:	MERV-11		
Efficiency:	Standard 65% Efficient, ASHRAE Dust Spot Test		
Size:	Size: 12" x 12" x 1"		
Power Cord:	8', 110-120 VAC, Ground		
Drain Connection:	5/8" hose barb or 3/4" FPT		
Drain Hose:	5/8" ID x 8' Direct Gravity Drain Hose		
Dimensions	Unit	with Duct Kit:	Shipping
Width:	14.5"	14.5"	17"
Height:	19.5"	23"	20"
Depth:	34"	40.5"	36"
Weight:	67 lbs		73 lbs

4. Unit Assembly

4.1 Installing Feet (Optional)

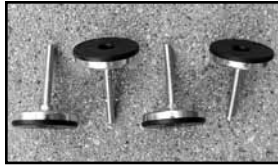

Figure 1: Four leveling feet

Included with your Santa Fe Advance are four leveling feet. It is important to level the unit for proper draining. (See section 5.1.4, Figure 6)

Installing Leveling Feet

See Figures 2 and 2a for installing leveling feet.

1. Lay down a protective pad (pillow, blanket, etc.).
2. Carefully turn unit onto side opposite filter opening and drain port.



Figure 2: Insert leveling feet in locations



Figure 2a: Screw each leveling foot in ten revolutions

3. Align leveling foot shaft with one of the four threaded hole locations as shown in Figure 2.
4. Screw each leveling foot in ten revolutions.
5. Carefully bring unit to upright position.
6. Level unit for proper drainage as described in section 5.1.4 (Figure 6) of this manual.
7. Wait 10 minutes before operating.

CAUTION!

Note: Operating the unit immediately after bringing it to an upright position can possibly damage the compressor. A short amount of time is needed to allow the oil to return to its reservoir for lubrication.

4.2 Drain Hose

Take drain hose off of drain port. With scissors, cut one inch off of hose end to eliminate dented area. Place drain hose end on drain port until fully seated. Refer to Section 5.1.4 regarding proper drainage.

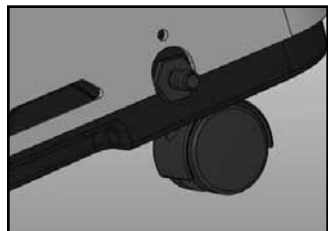

Figure 3: Drain port



Figure 2a: Drain hose position

5. Installation

5.1 Location

The Santa Fe Advance can be installed in a variety of locations to meet the owner's needs, but should be installed directly in the area to be dehumidified. Other considerations include:

1. Providing access to a 115 VAC power outlet (8' power cord is provided).
2. Locating near a floor or other suitable drain (8' drain hose included).
3. Do not install the Santa Fe Advance with the intake or exhaust of the unit within 1' of a wall or other obstruction. Do not place the unit where curtains or debris can be drawn onto the intake and restrict airflow. Do not operate in standing water or place the unit near open water. Refer to Figure 5.
4. The Santa Fe Advance drains via a gravity system. A level indicator has been included near the intake of the unit. To ensure the unit will drain properly, the unit should be positioned so the level bubble appears in the non-shaded area of the level indicator as shown. Refer to Figure 6. If the unit is placed on an unlevel surface, adjust leveling feet using a crescent wrench or 7/16" open wrench. Move handle end of wrench from left to right to lower one foot. Adjust all four feet underneath the unit until bubble in the level dial is in the correct position. Failure to level the unit may result in leakage or improper drainage. See Section 4.2 regarding drain hose installation.

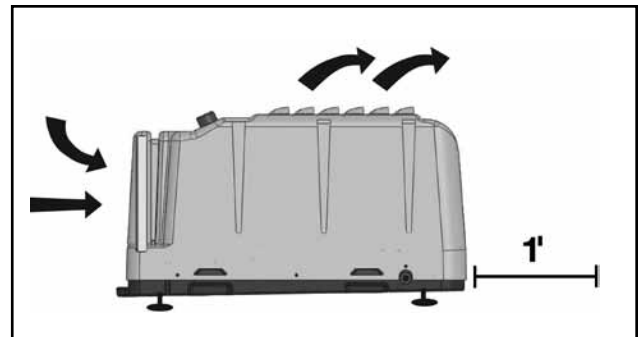

Figure 5: Installing Santa Fe Advance in area with proper clearance.

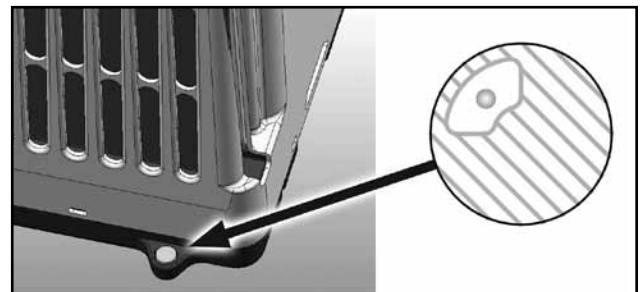

Figure 6: Level bubble should be in indicator area for proper drainage.

5.2 Electrical Requirements

The Santa Fe Advance plugs into a common grounded outlet on a 15-Amp circuit. While operating, it draws less than 7 amps @ 80°F, 60% RH and less than 6 amps @ 75°F, 50% RH. Use of a ground fault circuit interrupter (GFCI) protected circuit is recommended. The unit should not be used in areas prone to flooding.

5.3 Condensate (Water) Removal

The Santa Fe Advance drains via a gravity system - it is not able to push condensate (water) uphill. The drain hose must run flat or downhill toward the drain location. Be sure the hose is not kinked or otherwise restricted so that water can pass through it. Improper hose installation may result in water leakage.

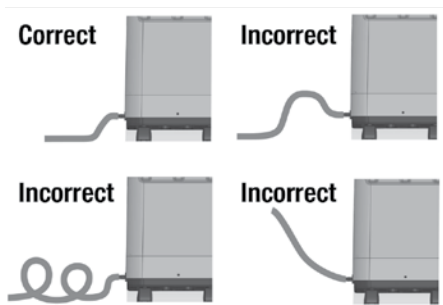

Figure 7: Drain hose position

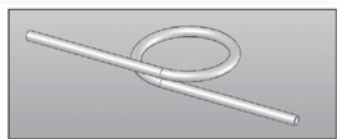

Figure 8: Optimum hose position for draining.

To increase the efficiency of the unit, position the hose to create a “trap” as shown in Figure 8. By creating a trap, it will hold a small amount of water. Position the trap on the hose approximately 12” to 20” away from the unit. Check hose regularly to ensure it is clear and water is draining properly.

If floor drain is not easily accessible, a condensate pump kit with a 20' hose is available. Refer to page 5 for ordering accessories.

6. Operation

6.1 Humidity Control Adjustment

The humidity control is an adjustable switch that turns the dehumidifier on and off. It turns on when the relative humidity of the air in which it is located rises to the dial set point. It turns off when the RH drops 5% below the set point.

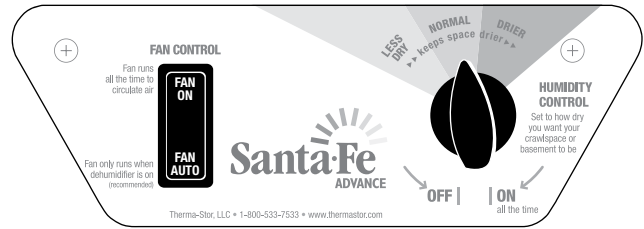

Figure 9: Dial shown in recommended position.

Approximate Humidity Levels Per Setting

- “Dry” 35% to 45% Relative Humidity
- “Normal” 45% to 55% Relative Humidity (Recommended for most applications)
- “Humid” 55% to 65% Relative Humidity

The dehumidifier will run continuously until the relative humidity (RH) is reduced to the humidity control dial setting. There is no benefit to setting the humidity control to “dry” in rooms under 65°; doing so will result in long periods of ineffective dehumidifier run time.

Quality humidity meters are available from Therma-Stor and are recommended to accurately monitor humidity levels. Please call 1-800-533-7533 to order.

Once the dial has been set to the desired level of humidity control, the Santa Fe Advance will maintain the same percentage of relative humidity regardless of room temperature.

To turn the unit off, position the humidity dial to the far left and set fan control to “auto.”

6.2 Defrost Cycle

An automatic defrost thermostat is attached to the refrigerant tubes inside the unit. It will automatically shut the compressor off if excessive frost forms on the evaporator coil. The blower will continue to run, causing air to flow through the evaporator coil and melt the ice. When the ice has melted, the evaporator temperature will rise and the thermostat will automatically restart the compressor. During this process, cool air may be coming out of the unit.

6.3 Electrical Requirements



Turning the fan switch “FAN ON” will cause the unit’s internal blower to run continuously, whether the unit is dehumidifying or not. This function is desirable if the unit is used for air circulation or filtration. Turning the fan switch to “FAN AUTO” will cause the unit’s internal blower to run only while the unit is dehumidifying.

7. Maintenance

⚠ CAUTION!

NOTE: Do not operate the unit without the proper filter or with a less effective filter. The heat exchange coils inside the unit could become clogged, resulting in a loss of effectiveness and/or efficiency and may require disassembly to clean.

7.1 Air Filter

The Santa Fe Advance ships with a standard MERV-11 65% 1" pleated fabric filter and a 1/4" aluminum framed pre-filter installed. Operating the unit with a dirty or obstructed filter will reduce dehumidifier capacity and efficiency and may cause the compressor to cycle on and off unnecessarily.

7.2 Cleaning & Replacement

Check filters every six months. Clean and/or replace when filters are visibly dirty. See cleaning instructions below. Replacement filters can be ordered from Therma-Stor by calling 1-800-533-7533.

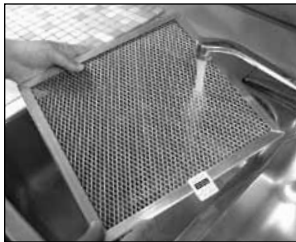

Figure 11: Pre-filter rinsed in water, screen side up.

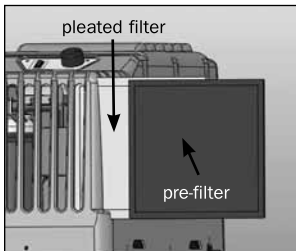

Figure 12: Filter installation.

⚠ CAUTION!

NOTE: Failure to follow filter handling instructions may result in improper function of the dehumidifier and cause premature filter wear.

7.3 Remove Filters

1. Gently remove the 1/4" pre-filter by pulling on the tab attached to the filter.
2. Gently remove the 1" pleated fabric filter by pulling it out of the unit.

7.4 Installing Filters

1. Gently slide 1" pleated filter into filter slot. Do not force. If resistance is felt, check alignment for obstructions or debris inside the filter housing.
2. Gently slide 1/4" pre-filter to left of 1" pleated filter. Do not force. If resistance is felt, check alignment for obstructions or debris inside the filter housing.

8. Service

⚠ WARNING!

Servicing the Santa Fe Advance with its high pressure refrigerant system and high voltage circuitry presents a health hazard which could result in death, serious bodily injury, and/or property damage. Only qualified service people should service this unit.

8.1 Technical Description

The Santa Fe Advance uses a refrigeration system similar to an air conditioner's to remove heat and moisture from incoming air and add heat to the air that is discharged. Hot, high pressure refrigerant

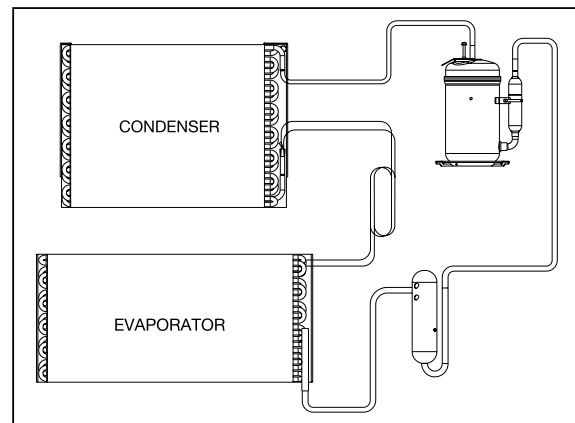

Figure 13: Santa Fe Advance refrigeration system.

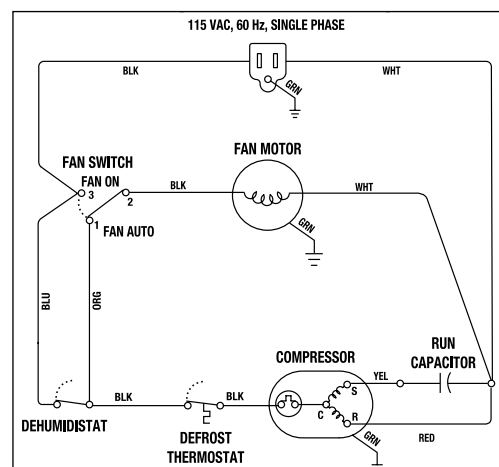

Figure 14: Wiring diagram.

gas is routed from the compressor to the condenser coil. The refrigerant is cooled and condensed by giving up its heat to the air that is discharged from the dehumidifier. The refrigerant liquid then passes through capillary tubing which cause the refrigerant pressure and temperature to drop. It next enters the evaporator coil where it absorbs heat from the incoming air and evaporates.

The evaporator operates in a flooded condition, which means that all the evaporator tubes contain liquid refrigerant during normal operation. A flooded evaporator should maintain constant pressure and temperature across the entire coil, from inlet to outlet. The mixture of gas and liquid refrigerant enter the accumulator after leaving the evaporator coil. The accumulator prevents any liquid refrigerant from reaching the compressor. The compressor evacuates the cool refrigerant gas from the accumulator and compresses it to a high pressure and temperature gas to repeat the process.

8.2 Troubleshooting

No dehumidification. Neither blower, nor compressor run with fan switch AUTO.

- 1 Unit unplugged or no power to outlet, circuit breaker tripped.
- 2 Humidity control set to "Humid" setting.
- 3 Loose connection in internal wiring.
- 4 Humidity control is defective.

No dehumidification. Compressor does not run but blower runs with fan switch AUTO and humidity control turned to ON.

- 1 Defrost thermostat open, ambient temperature too low.
- 2 Loose connection in compressor circuit.
- 3 Defective compressor overload.
- 4 Defective compressor or compressor run capacitor.

Blower runs with fan switch AUTO but compressor cycles on & off.

- 1 Low ambient temperature and/or humidity causing unit to cycle through defrost mode.
- 2 Defrost thermostat defective.
- 3 Defective compressor overload.
- 4 Defective compressor.

Blower does not run with fan switch in either position. Compressor runs briefly but cycles on and off.

- 1 Loose connection in blower circuit.
- 2 Obstruction prevents impeller rotation.
- 3 Defective blower.
- 4 Defective blower switch.

Evaporator coil frosted continuously, low dehumidifying capacity.

- 1 Dirty air filter or air flow restricted.
- 2 Defrost thermostat loose or defective.
- 3 Low refrigerant charge.

If none of the above has fixed the issue, call the service department at 1-800-533-7533.

9. Optional Accessories

4025845	Condensate pump kit
4026055	Duct connection kit
4026607	Leveling casters set (4)

9.1 Replacement Parts

4025568	Pleated Air Filter .88" x 11.75" x 11.75"
4025831	Pre-Filter
4021495	Control Knob
4025577	Hose, PVC, Clear, .625" diameter, 8' long
4026450	Leveling Feet

9.2 Service Parts

4025561	Blower Assembly
4029801	Coil Assembly
4029168	Compressor
4029169	Compressor Overload
4025741	Defrost Thermostat
4025560	Fan Switch
4029510	Filter Drier
4021469	Humidity Controller
4029845	Run Capacitor

For more information on the Santa Fe Advance, call 1-800-533-7533 or visit our website at www.thermator.com

SANTA FE ADVANCE CONDENSATE PUMP INSTALLATION



Optional Accessory: Condensate Pump Kit

P/N 4025845



Note: Before attaching pump assembly, ensure that the dehumidifier has leveling feet installed on bottom of unit. If your unit has casters, you will need order a set of leveling feet. Call 1-800-533-7533 and ask for Part Number 4026450. These will be needed for additional height. The mounting bracket is not to be used as a support bracket for the dehumidifier.

Step 1. Make sure leveling feet are installed. If you need to order another set, call 1-800-533-7533, and ask for Part Number 4026450.



Step 2. Remove middle top cover screw located on the drain port side. Do not discard this screw. It will be used to attach the mounting bracket in the next step.

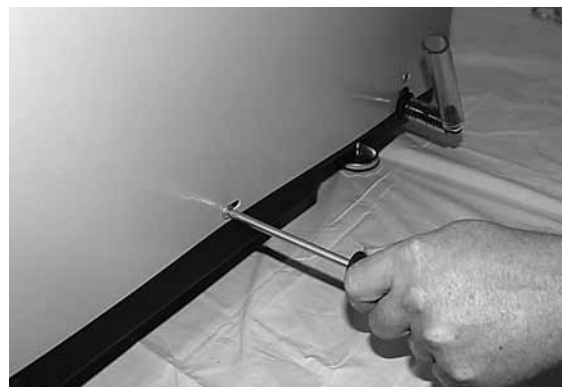

Step 3. Align mounting bracket of condensate pump with the dehumidifier screw hole. Reinstall screw that was removed in step 2.

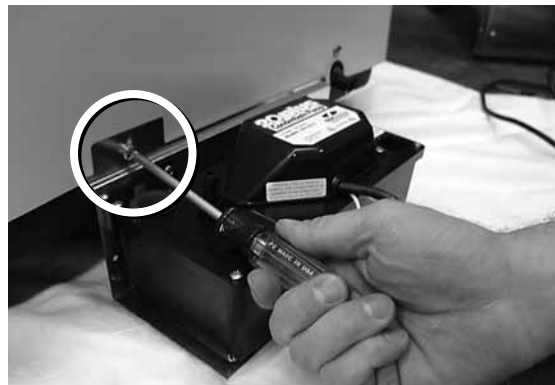

Step 4. Remove the 7" hose from the plastic bag and install this hose from the condensate pump onto the adaptor as indicated. Make sure that the hose fully covers the adaptor barbs on the unit.



SANTA FE ADVANCE CONDENSATE PUMP INSTALLATION

Step 5. Attach the 20' drain hose to the condensate pump and route it to a floor drain.



Plug in the condensate pump and the assembly is completed.



Optional Accessory: Duct Kit

P/N 4026055



Santa Fe Advance Duct Kit Assembly Instructions

Do not drill any pilot holes into the plastic housing. You may damage the internal components. When installing screws, be careful not to strip. Lightly tighten screws.

ATTACHING COLLARS

Step 1. Position collar on a flat surface with tabs up.



Step 2. Position collar into large hole. Press firmly so that tabs of collar go through the plenum hole



Step 3. Press down firmly on the sheet metal plenum. Lock the collar in position by bending the collar tabs outwards and flatten



Step 4. All collar tabs are flattened. Repeat steps 1 – 4 for top duct assembly.

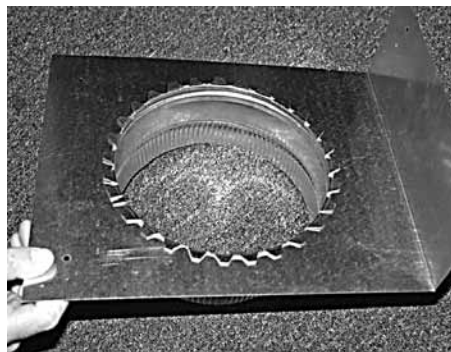

Instructions continued on next page →

Santa Fe Advance Duct Kit Assembly Instructions Continued

Screw pan head 10-16 x 1/2 @ 8 locations after the rear flange has been secured. Drive these 2 screws into the plastic housing.

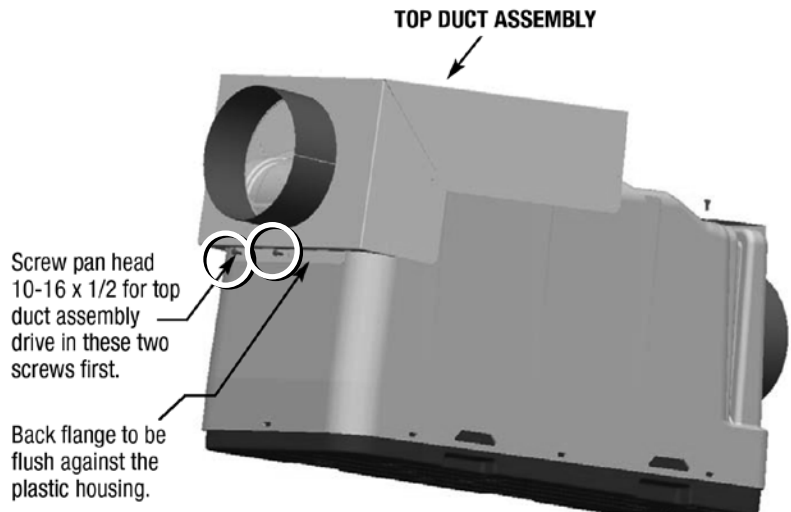
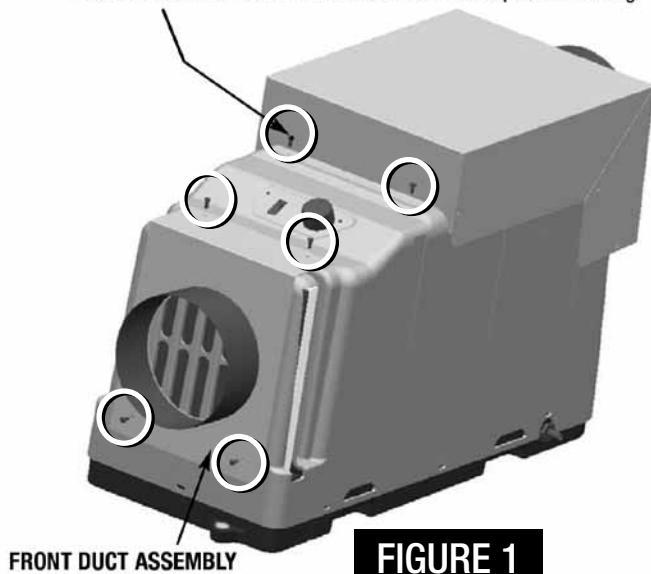

Screw pan head 10-16 x 1/2 for top duct assembly drive in these two screws first.

Back flange to be flush against the plastic housing.

FRONT DUCT ASSEMBLY

1. Check sealing foam on the front duct assembly. Ensure that none has come loose.
2. Place front duct assembly on the intake side of the dehumidifier.
3. Center the front duct assembly. Ensure the sealing foam makes contact around the plastic intake grill surface. Sealing foam should not cover any of the inlet portion of the intake grill.
4. **DO NOT DRILL PILOT HOLES FOR SCREWS. You will risk possibly damaging the internal components.** Using the through holes provided in the top duct assembly, screw in the four 10-16 X 1/2 screws directly into the plastic housing (see Figure 1 — screws indicated in white circle). Be careful not to strip loose. Lightly tighten screws. Do this in all four through hole locations.

TOP DUCT ASSEMBLY

1. Check sealing foam on the top duct assembly. Ensure none has come loose.
2. Place top duct assembly, ensure the sealing foam makes contact around the plastic surfaces.
3. Center the top duct assembly, ensure the sealing foam makes contact around the plastic surfaces.
4. Ensure the rear flange of the top duct assembly is seated flush against the back of the plastic housing. See Figure 2.
5. **DO NOT DRILL PILOT HOLES FOR SCREWS. You will risk possibly damaging the internal components.** Using the through holes provided in the top duct assembly, secure back flange of the top duct assembly first. Drive two 10-16 X 1/2 screws directly into the plastic housing. After the back flange has been secured, drive in the last two screws (located on the top) into the plastic housing using the same procedure.
6. Start unit and check for any air leaks around the perimeter of the ducts.
7. If any leaks are found, seal leak with foil tape.



Santa Fe ADVANCE Limited Warranty

Limited Warranty. Therma-Stor, LLC (“Therma-Stor”) warrants as follows: (i) the Santa Fe Advance dehumidifier (“Product”) will be free of material defects in workmanship or materials for a period of one (1) year (“One-Year Warranty”) following the date of initial purchase of such Product by an original customer purchasing from Therma-Stor or an authorized reseller (“Customer”); and (ii) the Product’s condenser, evaporator, and compressor will be free of material defects in workmanship or materials for a period of five (5) years following the date of initial purchase of such Product by a Customer.

Limitation of Remedies. CUSTOMER’S SOLE AND EXCLUSIVE REMEDY UNDER THE ABOVE LIMITED WARRANTY AND THERMA-STOR’S ENTIRE LIABILITY THEREUNDER, SHALL BE, AT THE SOLE OPTION OF THERMA-STOR, REPLACEMENT OR REPAIR OF SUCH PRODUCT OR ITS COMPONENTS (“COMPONENTS”) BY THERMA-STOR OR THERMA-STOR’S AGENTS ONLY. REFRIGERANT, PIPING, SUPPLIES, TRANSPORTATION COSTS, LABOR COSTS INCURRED IN REPAIR OR REPLACEMENT OF SUCH COMPONENTS ARE NOT INCLUDED. THIS DISCLAIMER AND EXCLUSION SHALL APPLY EVEN IF THE EXPRESS WARRANTY AND LIMITED REMEDY SET FORTH HEREIN FAILS OF ITS ESSENTIAL PURPOSE. CUSTOMER ACKNOWLEDGES THAT NO REPRESENTATIVE OF THERMA-STOR OR OF ITS AFFILIATES OR RESELLERS IS AUTHORIZED TO MAKE ANY REPRESENTATION OR WARRANTY ON BEHALF OF THERMA-STOR OR ANY OF ITS AFFILIATES OR RESELLERS THAT IS NOT IN THIS AGREEMENT. Notwithstanding the above, during the term of the One-Year Warranty only, Therma-Stor will provide, free of charge to Customer, all Components and labor (except costs related to removal and installation of Product) required to fulfill its obligations under such One-Year Warranty.

Disclaimer of Warranties. EXCEPT FOR ABOVE LIMITED WARRANTY, WHICH IS THE SOLE AND EXCLUSIVE WARRANTY PROVIDED WITH RESPECT TO THE PRODUCT AND ITS COMPONENTS, THERMA-STOR HEREBY DISCLAIMS ALL EXPRESS AND IMPLIED WARRANTIES, INCLUDING, WITHOUT LIMITATION, THE IMPLIED WARRANTIES OF MERCHANTABILITY AND FITNESS FOR A PARTICULAR PURPOSE.

Warranty Limitations. The foregoing limited warranty extends only to a Customer and shall be null and void upon attempted assignment or transfer. A “defect” under the terms of the limited warranty shall not include problems resulting from Customer’s or Customer’s employees’, agents’, invitees’ or a third party’s misuse, improper installation, improper design of any system in which the Product is included, abuse, lack of normal care, failure to follow written instructions, tampering, improper repair, or freezing, corrosion, acts of nature or other causes not arising out of defects in Therma-Stor’s workmanship or material. If a Product or Component is replaced while under warranty, the applicable limited warranty period shall not be extended beyond the original warranty time period. The limited warranty does not cover any costs related to changes to a Product or Component that may be required by any codes, laws, or regulations that may become effective after initial purchase of the Product by Customer.

Customer Responsibilities. As a further condition to obtaining warranty coverage hereunder, the Customer must send a valid warranty claim to Therma-Stor such that Therma-Stor receives such claim prior to the end of the applicable warranty period. Therma-Stor shall have no obligation hereunder with respect to any claim received by Therma-Stor after the expiration of the applicable warranty period. As a further condition to obtaining warranty coverage hereunder, the Customer must present forms of invoices evidencing proof of purchase of a Product. If such invoices do not clearly indicate the date of initial purchase by a Customer, the applicable Product’s date of manufacture will be used instead of the date of initial purchase for the purpose of calculating the commencement of the applicable warranty period. Warranty service must be performed by Therma-Stor or a servicer authorized by Therma-Stor. In order to obtain warranty service, the Customer should call Therma-Stor at 1-800-533-7533 and ask for the Therma-Stor Products Service Department, which will then arrange for applicable warranty service. Warranty service will be performed during customary, daytime working hours. If the Product must be shipped for service, Customer shall be solely responsible for properly packaging the Product, for all freight charges, and for all risk of loss associated with shipment.

Limitation of Liability. IN NO EVENT SHALL THERMA-STOR, IN CONNECTION WITH THE DESIGN, SALE, INSTALLATION, USE, REPAIR, REPLACEMENT OR PERFORMANCE OF ANY PRODUCT, COMPONENT, PART THEREOF OR WRITTEN MATERIAL PROVIDED THEREWITH, BE LIABLE, TO THE EXTENT ALLOWED UNDER APPLICABLE LAW, UNDER ANY LEGAL THEORY FOR ANY SPECIAL, DIRECT, INDIRECT, COLLATERAL OR CONSEQUENTIAL DAMAGES OF ANY KIND. NOTWITHSTANDING THE ABOVE LIMITATIONS AND WARRANTIES, THE SOLE AND EXCLUSIVE LIABILITY OF THERMA-STOR, REGARDLESS OF THE NATURE OR THEORY OF THE CLAIM, SHALL UNDER NO CIRCUMSTANCES EXCEED THE PURCHASE PRICE OF THE PRODUCT, COMPONENT OR PART UPON WHICH THE CLAIM IS PREMISED.

Applicable Law and Venue. ANY ARBITRATION, ENFORCEMENT OF AN ARBITRATION OR LITIGATION RELATED TO THE PRODUCT WILL BE BROUGHT EXCLUSIVELY IN DANE COUNTY, WISCONSIN, AND CUSTOMER CONSENTS TO THE JURISDICTION OF THE FEDERAL AND STATE COURTS LOCATED THEREIN, SUBMITS TO THE JURISDICTION THEREOF AND WAIVES THE RIGHT TO CHANGE VENUE. CUSTOMER FURTHER CONSENTS TO THE EXERCISE OF PERSONAL JURISDICTION BY ANY SUCH COURT WITH RESPECT TO ANY SUCH PROCEEDING.

Miscellaneous. If any term or condition of this Limited Warranty is found by a court of competent jurisdiction to be invalid, illegal or otherwise unenforceable, the same shall not affect the other terms or conditions hereof or thereof or the whole of this Limited Warranty. Any delay or failure by Therma-Stor to exercise any right or remedy will not constitute a waiver of Therma-Stor to thereafter enforce such rights.



Therma-Stor[®] LLC

PO Box 8680 • Madison, WI 53708

Phone: 608-222-5301 • Fax: 608-222-1447

Web: www.thermastor.com • Email: sales@thermastor.com

Information in this document is subject to change without notice. No part of this document may be reproduced or transmitted in any form or by any means, electronic or mechanical, for any purpose, without the express written permission of Therma-Stor LLC. © 2006 Therma-Stor LLC. All rights reserved.
