

CONTROL TIPS

A ROBERTSHAW® INFORMATIONAL GUIDE

THIS ISSUE

HOW HUMIDIFICATION/DEHUMIDIFICATION FEATURES OPERATE

Congratulations, you are the proud owner of a Robertshaw® 9801i, 9815i, 9820i, 9851i, 9865i, or 9870i series thermostat. This Control Tips guide will provide you with the necessary information to set up your thermostat for maximum humidity and dehumidification operation.

MODES

Manual with Heating

When the thermostat has a call for heat, the W terminal is energized (24VAC). If the relative humidity (RH) drops 2% below RH setpoint, the H terminal is energized. When the temperature setpoint is reached, both terminals are de-energized and the fan will shut off after the purge cycle or remain on if the thermostat was set to Fan On.

Manual Independent

When the thermostat has a call (in heat mode) for humidity, and no call for heat, the H (24VAC) and G terminals are energized.

When a call for heat is made, the H and G terminals will remain on while the W terminal is energized. The fan remains on at the speed chosen for the furnace control for G only.

The second stage W2 energizes after a user-selected time (5 to 40 minutes) when the room temperature is 0.5°F above the setpoint, or a 2°F differential has been met.

Auto with Heating or Auto Independent

These features can be selected from the Humidity Menu, but only when an outdoor sensor (9025i) is connected. Humidity set point adjustment is an automatic adjustment made by the thermostat. The indoor Relative Humidity (RH) is adjusted based on the outdoor temperature compared to the indoor temperature. After the humidity set point has been automatically determined, there is a manual adjustment that can be selected ($\pm 1\%$ RH to $\pm 15\%$ RH) at 1% increments.

NOTE: When connecting the outdoor sensor, use a shielded, twisted pair of 18 guage 2-wire. The wire length should not exceed 300 feet.

USING THE INDEPENDENT HUMIDITY SETTING

Use the Independent Humidity setting with the outdoor sensor for dew-point adjustment so moisture will not condense or freeze on windows.

The **bypass humidifier** can be used, and is recommended, with the Independent Humidity setting. This will allow additional moisture to be added and distributed throughout the house without a call for heat. The added humidity would increase the comfort levels of the dwelling.

The **mist humidifier** generates more water directly than the other two types of humidifiers. The Independent Humidity setting SHOULD NOT be used.

If a **power (fan-style) humidifier** is used, (one equipped with a separate transformer) it will be necessary to use an isolation relay.

Recommended Settings

Auto Humidity Setting (AHS) +/- Dew Point Adjustment

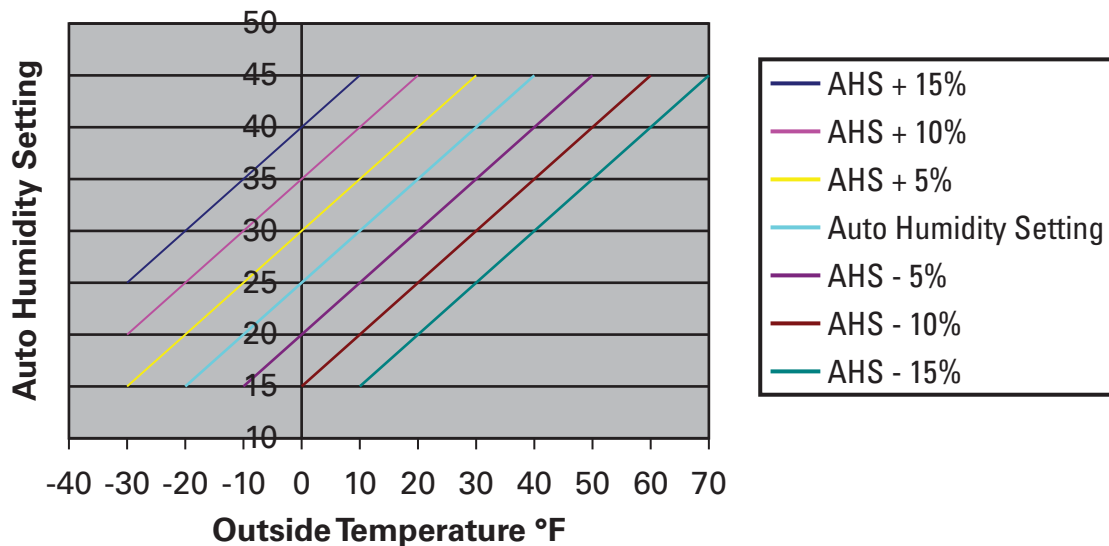

Application Example:

A **bypass humidifier** is installed with a down-flow furnace. The house temperature (setpoint is 73°F) is 75°F (The graph above shows that the automatic setpoint for RH is 30%, when the outdoor temperature is 10°F). The thermostat is user selected to the Auto humidity setting.

The humidifier and fan activate adding moisture to the dwelling as needed to reach 32%RH. The humidifier and fan will reactivate when the humidity drops below 28%RH. The setpoint is $\pm 2\%$ RH.

Condensation – If humidity levels cause condensation on windows, then this control needs to be adjusted. This adjustment must be made over a 12-hour period to allow the humidity levels to stabilize.

For instance, by selecting -5% RH on the adjustment, the humidity will maintain $25\% \pm 2\%$ RH with an outdoor temperature of 10°F. If -5% is not enough to avoid condensation, then lower the Auto Humidity Setting to -10% RH. The controlling RH will be $20\% \pm 2\%$ RH with an outdoor temperature of 10°F.

HUMIDIFIER TYPES

Bypass Humidifier

This humidifier takes heated air from the plenum, draws it through a water pad and deposits the moist air in the return. The most common operation works with heat only. If the furnace is on only for a short time, the humidified air cannot be distributed evenly through the house. In fact, the heat from the furnace will remove moisture.

Power Humidifier

This humidifier takes air (room temperature or heated) from the plenum, draws it through a water pad and forces the humidified air back into the plenum. This application allows more moisture to be distributed throughout the house. Some power humidifiers have transformers, and if this were the case, an isolation relay would have to be installed. An isolation or heavy-duty relay is also needed if the current draw of the power humidifier exceeds the 1 amp rating of the thermostat humidity relay contacts.

Mist or Steam Humidifier

This humidifier takes water or steam and sprays it into the plenum. Setting up this application is critical, as the water may not fully evaporate.

DEHUMIDIFICATION

The D output is energized (24VAC) on no call for dehumidification.

When dehumidification is required, then D becomes deactivated (0 VAC). This is reverse logic.

Some control boards on furnaces (that have variable speed motors) have the D connection and look for the voltage to maintain normal fan speed.

If the control board sees "0" VAC, then the control board automatically lowers the fan speed.

The 5-minute compressor short cycle time still applies in all modes of dehumidification.

COOLING

On a call for cooling, the thermostat will activate Y1 above the setpoint, and turn off below the setpoint for a 1° differential (default). The differential is user adjustable (0.5, 1, 2, or 3°F) in 0.5° increments.

For multistage units, the second stage cooling (Y2) follows the on-off 2nd stage temperature differentials. The default time (adjustable) is ten minutes.

MANUAL DEHUMIDIFICATION WITH COOLING

Dehumidification can become active only: 1) after the temperature rises to cause a cooling demand, and, 2) the RH is still 2% above RH setpoint.

If room RH is 2% above the RH setpoint and cooling turns on, then the D terminal will be active or de-energized (0 VAC). If dehumidification is successful before cooling requirements are met, then D will switch to inactive (24 VAC present) while cooling continues.

The Y1, and D terminals will revert to their original state when room temperature has been reached.

The G terminal will remain on until the residual time off delay has timed out. (User selectable 0, 30, 60 or 90 seconds. Factory default is 30 seconds.)

MANUAL INDEPENDENT DEHUMIDIFICATION

If RH rises 2% above RH setpoint, then D, G, and Y1 switch to active. (D becomes de-energized.) In addition, the unit will operate until one of two requirements are met: Either the temperature decreases 1-1/2F° below the temperature setpoint or the RH decreases to 2% below the RH setpoint. The resulting state depends on the room temperature at the time the dehumidification is satisfied. If the temperature is in the range such that the cooling demand is satisfied, then Y1 and G turn off with D. Otherwise there is a cooling demand from the present temperature, and Y and G stay active.

If dehumidification is active with no call for cooling, and cooling becomes active (Room temperature is above temperature setpoint +0.5° F.), then the thermostat stays in a dehumidification state until the humidity setpoint has been reached.

NOTE: If there is an existing fixed speed motor and the dehumidification feature is used, see the fixed speed motor wiring diagram below.

Fixed Speed Motor

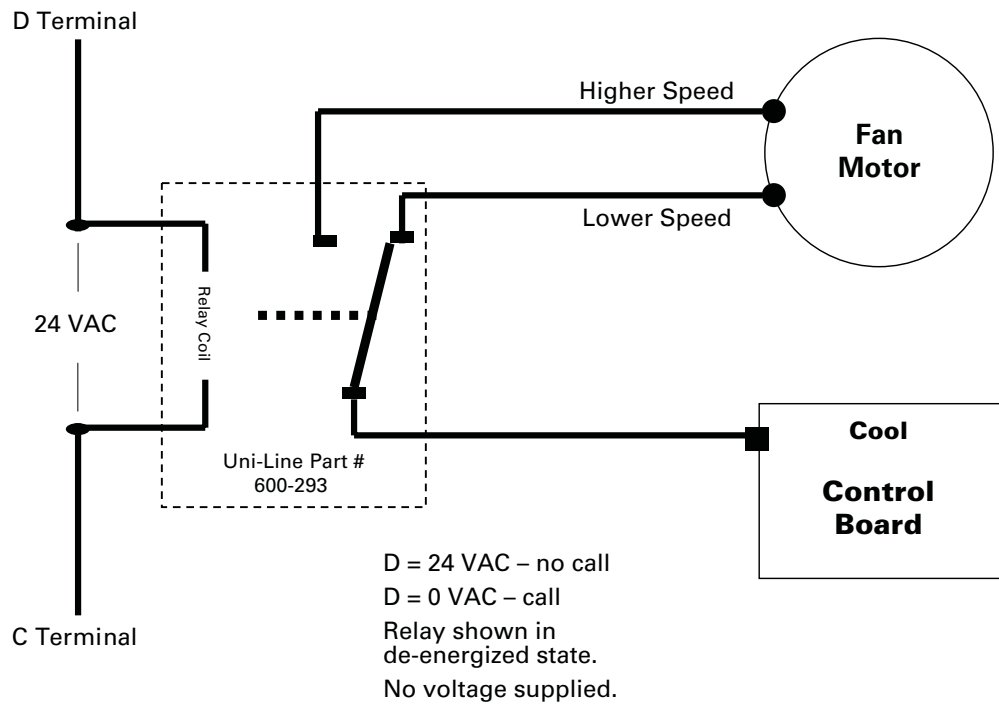

invensys.
Controls
 191 E. North Avenue
 Carol Stream Illinois 60188 USA
 Customer Service Telephone 1.800.304.6563
 Customer Service Facsimile 1.951.737.8261
 icccustomerservice@invensys.com
 www.invensyscontrols.com
 ©2007 Invensys Controls

For Technical Service
 Telephone 1.800.445.8299
 Facsimile 1.630.260.7243
 technicalservice@invensys.com

Invensys® and Robertshaw® are trademarks of
 Invensys plc., its subsidiaries and/or affiliated companies.

10/07 - 150-1992B