



SEALED UNIT PARTS CO., INC.

RIM316

ICEMAKER INSTRUCTIONS



PO Box 21 • 2230 Landmark Place • Allenwood, NJ USA
732-223-6644 • Fax 732-223-1617
www.supco.com • info@supco.com

Rev 08/03

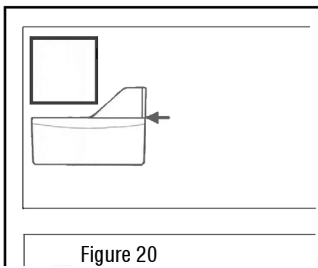

12. Reinstall the freezer shelf in a lower position, slide ice bin under icemaker (as shown in Figure 20). Left side of bin should be about even with the bottom of the lower bracket, to allow the icemaker to shut off before the bin overflows.

13. Attach Fill tubing to Fill tube, this is a friction fit and does not require adhesive or a clamp since it is not under pressure. Route the Filling tube for the icemaker down the back of the refrigerator (behind the condenser coils, if present). There are mounting clips provided. (see Figure 21 & 22)

14. Using factory predrilled mounting holes, attach water valve to the frame as shown in Figure 23. **Tip** : If space is limited attach icemaker fill line to valve before installing. You may need to reposition the eliminator tube on models with an internal condenser. Remember, finger tighten the compression fitting, then tighten with wrench an additional 1/4 to 1/2 turn. **DO NOT OVER TIGHTEN**, this will cause leaks and possible property damage.

15. Attach water valve connector to valve assembly (see Figure 24).

16. Purge the supply line to remove stale water, sediment and air. Attach a potable water supply to water valve. You may need to remove cutout on back cover if you have an internal condenser. (see Figure 25) Follow the installation instructions provided with the water supply line kit. **Trouble saving tip:** If you have an existing supply line, now is a good time to replace it, so examine the copper or plastic thoroughly to determine if it needs replacing. Look for wear marks, brittleness, fatigue lines, or damage. Rule of thumb; if in doubt replace it.

Icemaker Installation Instructions for RIM316

This kit is designed as an alternative for Whirlpool 1129316 and ECKMF-90

Before you start, check the wiring harness connector(s) supplied with this kit to make sure they match your electrical connections. If they do not, contact your dealer for the correct kit.



Figure 1

1. Disconnect power. To prevent shock hazard, injury, or possible death, disconnect all electrical power to the appliance before any work is started. You will need to access both the freezer compartment and the back of the Refrigerator / Freezer for this installation.

2. Identify the model style you are adding an icemaker to, see Figures 2, 3, & 4. For further references.

3. This icemaker is for pre-wired refrigerator / freezers, if your refrigerator / freezer is not prewired, please contact your dealer for the correct icemaker unit. Most prewired units have protective plugs and covers over the water and electrical connections. Using a screwdriver or putty knife, gently remove these plugs see Figure 5. Typically the electrical harness cover is attached with a 1/4" hex head Phillips™ head screw, remove this cover also. Check the electrical connection in this icemaker to make sure that the connector is the right one for this refrigerator, if not contact your distributor for the correct icemaker.



Figure 21

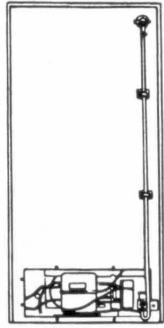

Figure 22

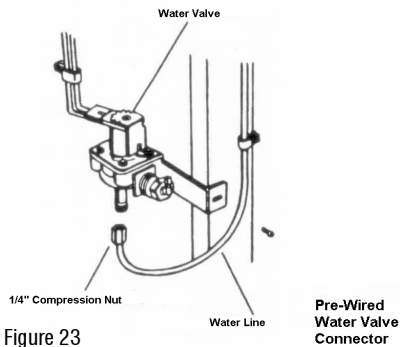

Figure 23

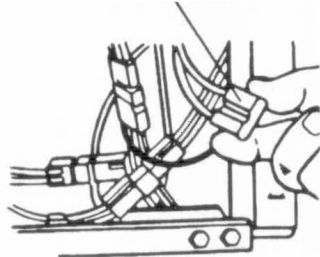

Figure 24

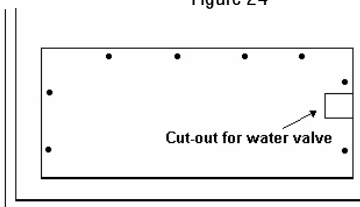

Figure 25

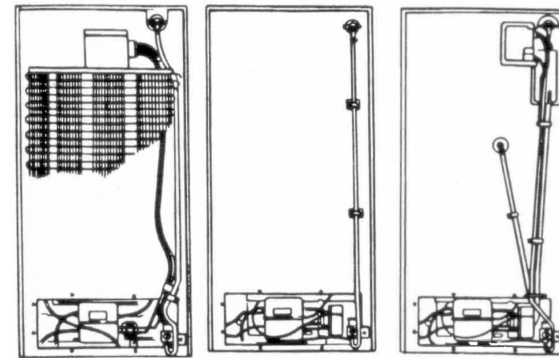

Figure 2
Condenser Back Model

Figure 3
Interior Condenser Smooth Back Model

Figure 4
Interior Condenser External Wiring Model

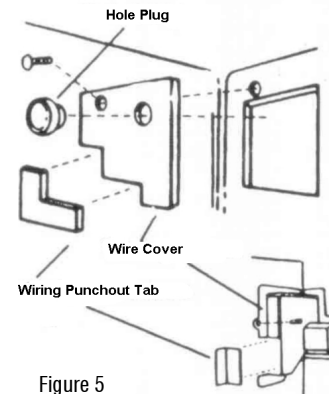

Figure 5

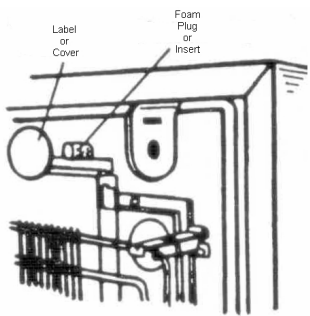

Figure 6

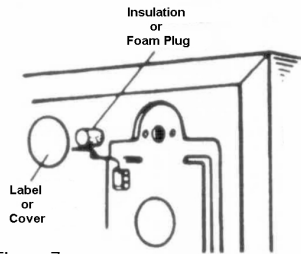

Figure 7

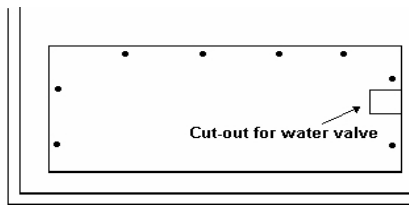

Figure 8

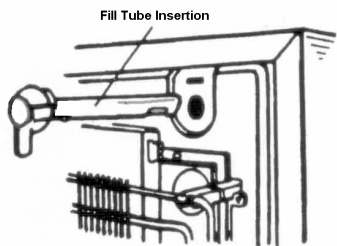

Figure 9

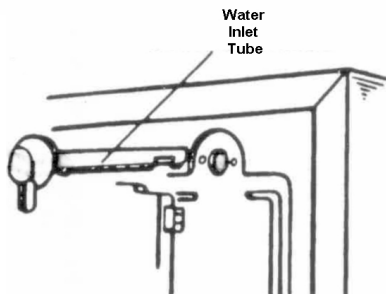

Figure 10

4. Looking at the back of the refrigerator, for external condenser coil models see Figure 6, for smooth back or external wiring models see Figure 7. **SAFETY! For external condenser models, cover the wire grid along the top with card board or cloth to protect you from cuts and scrapes.** If you have an external condenser coil, you may need to loosen the right side mounting clips to route the water fill tubing and to attach the fill tubing mounting clips. **Caution, be careful with the coil if you have to move it, damage can occur to the cooling system.**

5. Locate the inlet cover for icemaker installation, for external condenser coils see Figure 6, for smooth back models see Figure 7. The inlet cover may have a plug or a label covering the inlet opening. If it is a plug, gently remove the plug with a putty knife or screwdriver. If there is a label, there will be a "cut here" pattern, using a sharp knife to cut as directed on the label. Remove the underlying insulation using needle nose pliers. Fold cut label into opening to clear opening.

6. If the condenser coil is interior (see Figure 8), you will need to remove the screws that attach the access cover at the bottom of the unit. While cover is off look to see if you need to cut away the opening for the water inlet valve.

7. Push water inlet tube through the installation hole in the back of the unit, see Figure 9 for external condenser models, see Figure 10 for internal condenser models. Using a circular motion as you push through the insulated area between the case and the inner liner, will make this easier.

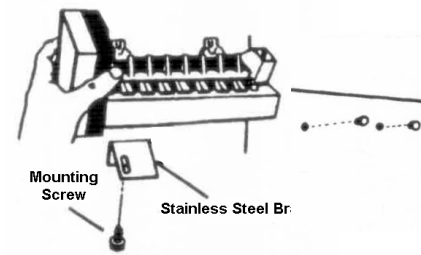

Figure 11



Figure 12

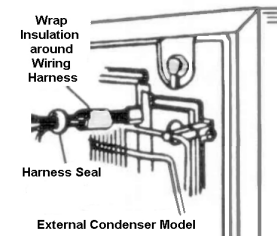

Figure 13

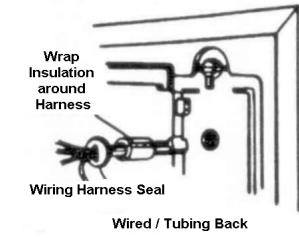

Figure 14

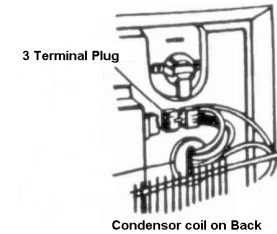

Figure 15

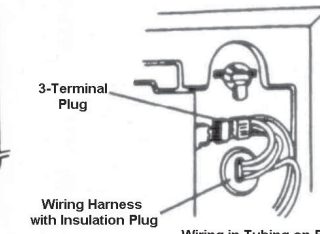

Figure 16

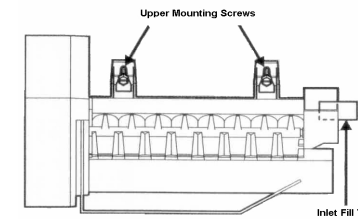

Figure 17



Figure 18

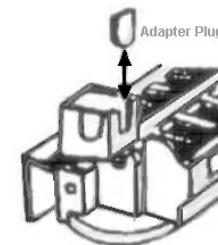

Figure 19

8. Attach stainless steel mounting bracket to the bottom of the icemaker (see Figure 11), do not tighten, you will need to adjust this bracket as you mount the icemaker. Start the two long screws into the holes provided along the top left side of the refrigerator. Alternate mounting; (see Figure 12) slip mounting clips into square mounting holes and push down until clips are firmly mounted.

9. This step not required on smooth back models. Wrap foam pad (previously removed from opening), around wiring (see Figure 13 & 14), to protect from abrasion. If insulation was damaged, wrap with electrical tape to protect the wiring.

10. Connect the icemaker 3 terminal plug to the connector on the back of the refrigerator (see Figure 15 & 16). On the "coil on the back" models, route the tan and white wires down and behind the condenser coil. On the "wiring / tubing" models, run beside existing tubing using existing clips.

11. Make sure the water inlet tube is in the fill tray (see Figure 17) and the electrical connection is correct. Insert the provided screw under the icemaker, level the icemaker and tighten all of the screws. You may need the fill tube extension shown in Figure 18, if required, slip on to fill tub and twist into place. If the side port on the fill tray needs to be filled (see Figure 19), a plug adapter is provided.

17. Return refrigerator to original position, check to make sure refrigerator and icemaker are level.
18. Turn on water supply and check for leaks.
19. Re-connect power to refrigerator.
20. Turn icemaker on by making sure lever arm is in the down position (to turn off lift arm to stop position).
21. The icemaker will need to cycle for about 24 hours to make quality ice. Please discard any ice made in the first 24 hours. This will allow the system to purge air, stale water and rinse any dust from the inside of the icemaker.

Quality Ice

Remember quality ice starts with quality water. A water filter will prolong the life of the water inlet valve. An activated charcoal filter will remove sediment, chlorine, fluoride, taste and odors. The freezer needs to be set at 10 degrees Fahrenheit or colder. The water pressure must be between 15 psi and 125 psi (see Figure 26 for water level adjustment). If you are not connected to a state regulated water supply, a filter is a must. If you have a water softener, connect the icemaker to the water supply before the softener. The chemicals dramatically shorten the life of the icemaker and valve.

