



EV9337-11

# QC7I Quad-MC<sup>2</sup> System

Delivers premium quality water for fountain applications



QC7I Quad-MC<sup>2</sup> System: EV9337-11

MC<sup>2</sup> Replacement Cartridge: EV9612-56

## BENEFITS

Reduces chlorine taste and odor and other offensive contaminants that can adversely affect the taste of beverages

New and improved Micro-Pure II media inhibits the growth of bacteria

Improves the taste of fountain beverages and helps retain the drink's carbonation

Precoat submicron technology reduces dirt and particles as small as 1/2 micron in size and reduces possible health contaminants such as cysts

Protects drink system seals, pump, tubing and small orifices from clogging, corrosion and abrasive wear

Manifold features water shut off, flushing valve, inlet and outlet pressure gauges

Sanitary cartridge replacement is simple, quick and clean. Internal filter parts are never exposed to handling or contamination

NSF Certified under NSF/ANSI Standards 42 and 53

## INSTALLATION TIPS

Choose a mounting location suitable to support the full weight of the system when operating

Never use saddle valve for connection

Use 3/4" water line

Install vertically with cartridges hanging down

Allow 2-1/2" clearance below the cartridge for easy cartridge replacement

Flush cartridges by running water through system for five minutes at full flow

## OPERATION TIPS

Change cartridges on a regular 6 month preventative maintenance program

Change cartridges when capacity is reached or when pressure falls below 10 psi

Service flow rate must not exceed 6.68 gpm

Always flush the filter cartridge at time of installation and cartridge change

## APPLICATION/SIZING

For fountain beverage applications

For dispensers with up to 4 carbonators

For separate high flow, high volume applications

Rated Capacity: 36,000 gallons

# QC7I Quad-MC<sup>2</sup> System

## SPECIFICATIONS

Overall Dimensions:  
25.69"H x 24.6"W x 5.5"D

Inlet connection: 3/4"

Outlet connection: 3/4"

Service Flow Rate:  
Maximum 6.7 gpm (25.4 Lpm)

Rated Capacity: 36,000 gallons

Pressure Requirements:  
10 - 125 psi (0.7 - 8.6 bar), non-shock

Temperature: 35 - 100°F (2 - 38°C)

No electrical connection required

Shipping Weight: 20 lbs.

Operating Weight: 32 lbs.

The contaminants or other substances removed or reduced by this drinking water system are not necessarily in your water. Do not use with water that is microbiologically unsafe or of unknown quality without adequate disinfection before or after the system. Systems certified for cyst reduction may be used with disinfected water that may contain filterable cysts.

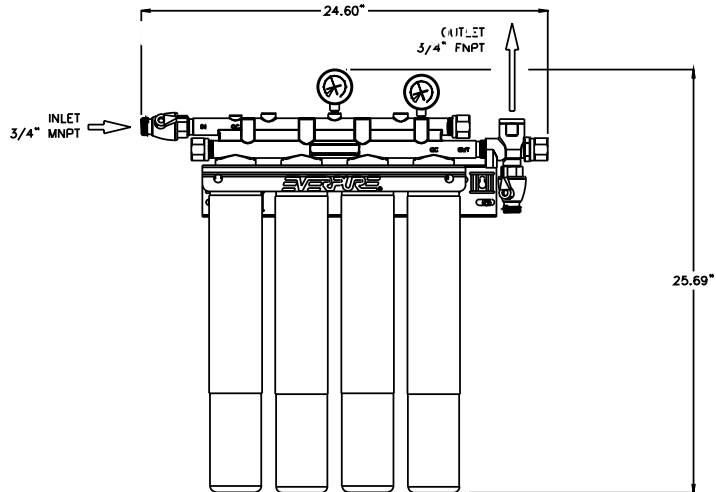

## WARRANTY

Everpure water treatment systems (excluding replaceable elements) are covered by a limited warranty against defects in material and workmanship for a period of five years after date of purchase. Everpure replaceable elements (filter cartridges and water treatment cartridges) are covered by a limited warranty against defects in material and workmanship for a period of one year after date of purchase. See printed warranty for details. Everpure will provide a copy of the warranty upon request.



System Tested and Certified by NSF International against NSF/ANSI Standard 42 and 53 for the reduction of:

Standard No. 42: Aesthetic Effects  
Chemical Unit  
Taste and Odor Reduction  
Chlorine Reduction  
Mechanical Filtration Unit  
Particulate Reduction, Class I:  
99.9+% reduction of particles  
one-half micron and larger in size  
Standard No. 53: Health Effects  
Mechanical Filtration Unit  
Turbidity Reduction  
Cyst Reduction  
Asbestos Reduction

### EVERPURE®

Worldwide Headquarters:  
EVERPURE, LLC  
1040 Muirfield Drive  
Hanover Park, Illinois 60133  
Toll Free (800) 323-7873  
Tel (630) 307-3000  
Fax (630) 307-3030  
<http://www.everpure.com>

In Europe:  
Pentair Water Belgium B.V./B.A.  
Industriepark Wolfstee  
Toekomstlaan 30  
B-2200 Herentals  
BELGIUM  
TEL: +32.(0).14.283.500  
FAX: +32.(0).14.283.505

In Japan:  
Hashimoto MN Bldg. 7F  
3-25-1 Hashimoto Sagamihara-Shi  
Kanagawa 229-1103  
JAPAN  
TEL: 81.(0)42.775.3011  
FAX: 81.(0)42.775.3015