



© 2006 Lennox Industries Inc.  
Dallas, Texas, USA

## AIR CLEANERS / FILTERS

TP Technical  
Publications  
Litho U.S.A.

505,276M  
03/2007

# PUREAIR™ AIR PURIFICATION SYSTEM PHOTOCATALYTIC OXIDATION TECHNOLOGY (PCO)

## INSTALLATION INSTRUCTIONS FOR PUREAIR™ AIR PURIFICATION SYSTEM MODELS PCO14-23, PCO16-28 AND PCO20-28

### RETAIN THESE INSTRUCTIONS FOR FUTURE REFERENCE

#### Shipping & Packing List

Assembled PureAir™ air purification system which includes:

- 1 - Cabinet
- 1 - Control box assembly (includes frame, ballasts and associated wiring)
- 1 - MERV 16 pleated filter
- 2 - UVA lamps
- 1 - Titanium dioxide metal insert
- 1 - Power cord (120VAC)\*

\*230VAC power cord available separately (part number 91X44).

A warranty certificate and registration card are also included.

#### Shipping Damage

Check equipment for shipping damage. If damage is found, immediately contact last carrier.

#### General Information

The PureAir™ air purification system uses photocatalytic oxidation (PCO) technology to significantly reduce levels of airborne volatile organic compounds, cooking odors, common household odors, airborne dust particles, mold spores and pollen. The PureAir™ system is available in three models: PCO14-23, PCO16-28 and PCO20-28. Each unit may be connected to either 120VAC or 230VAC power supply. If 230VAC power supply is used, a 230VAC power cord must be ordered separately.

Lab tests confirm a 50% reduction in total volatile organic compounds (TVOC) within the first 24 hours of initial operation of the PureAir™ air purification system. It may take up to 48 hours after initial system start-up to reduce the airborne chemicals that have built up in a home over a long period of time.

For peak performance, unit should be installed in homes with TVOC levels that are less than 1000 µg/m<sup>3</sup>. Home source removal and ventilation may be required to lower TVOCs to this level.

03/07



### NOTICE

**This system is NOT intended to be used for removal of active mold growth or continuous sources of high levels of chemicals in the air.**

**For existing mold growth, the mold must be properly removed PRIOR to installation of the PureAir™ air purification system.**

### ⚠ WARNING

**Risk of property damage, injury, or death.**

**Installation and service must be performed by a qualified installer or service agency.**

### ⚠ WARNING

**Electric shock hazard.**

**Can cause injury or death.**

**Disconnect all electrical power supplies before servicing. Access panels must be in place during appliance operation.**

### ⚠ CAUTION

**Sharp edges hazard.**

**Sharp edges can cause injuries.**

**Use protective gloves when grasping equipment edges.**

### NOTICE

**Possible odor emissions. Chemical reactions may cause temporary odors after initial start-up or after lamp replacement. Odor may also be present after paint, cleaning solutions or hobby materials have been used in the conditioned space.**

**Some occupants may experience irritation or discomfort during this period. If the irritation or discomfort lasts longer than 48 hours, the homeowner should be advised to contact a Lennox dealer.**

#### Unique Field-Supplied Installation Items

- Cotton gloves and cloth (to remove finger prints from lamps)
- Aluminum foil tape or water-based mastic (NOT silicone) to be applied as a sealant.

505,276M



## Parts Identification

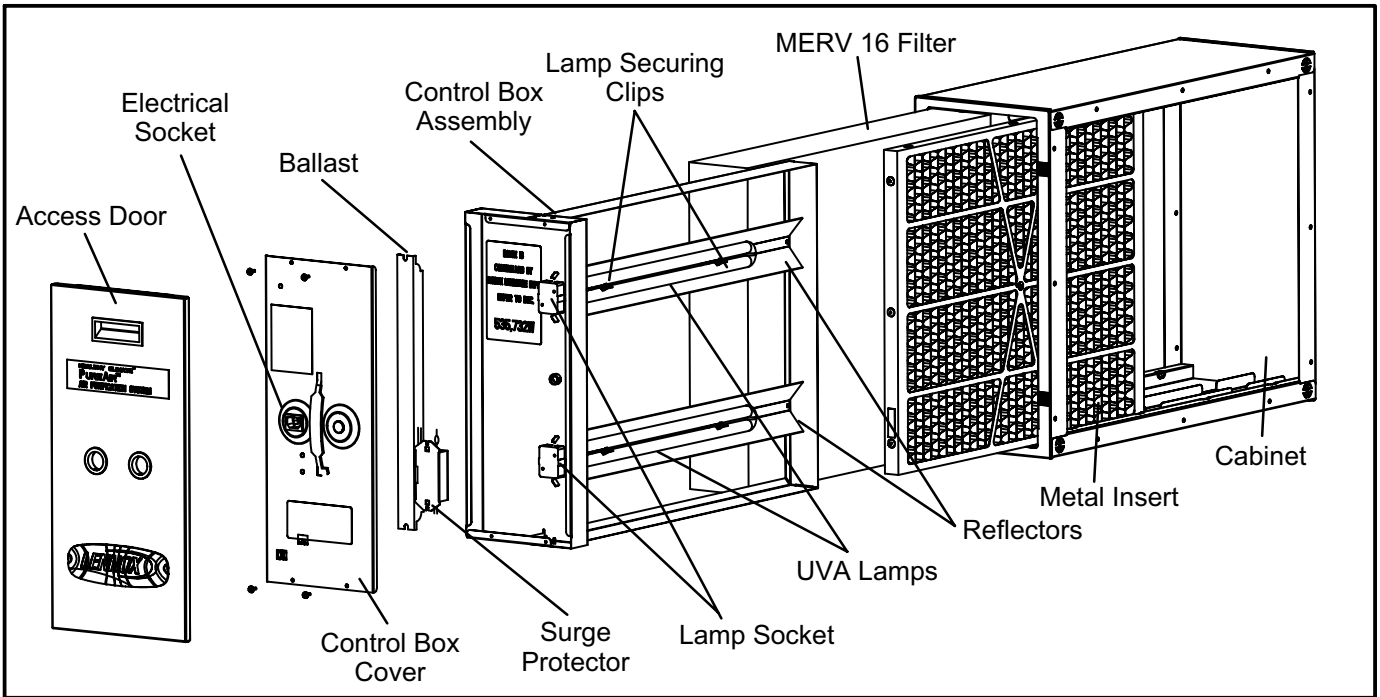

Figure 1

## Installation Examples

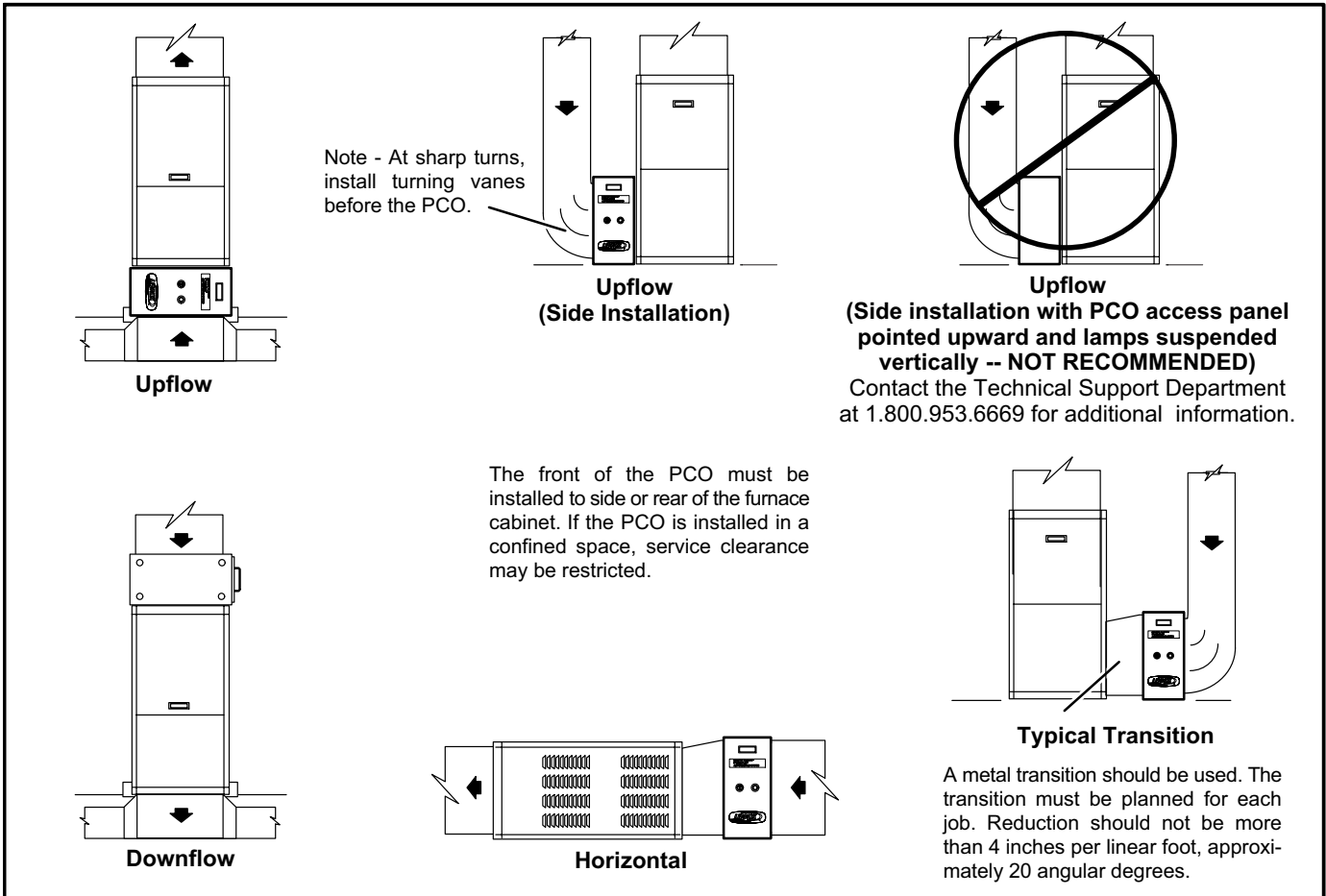
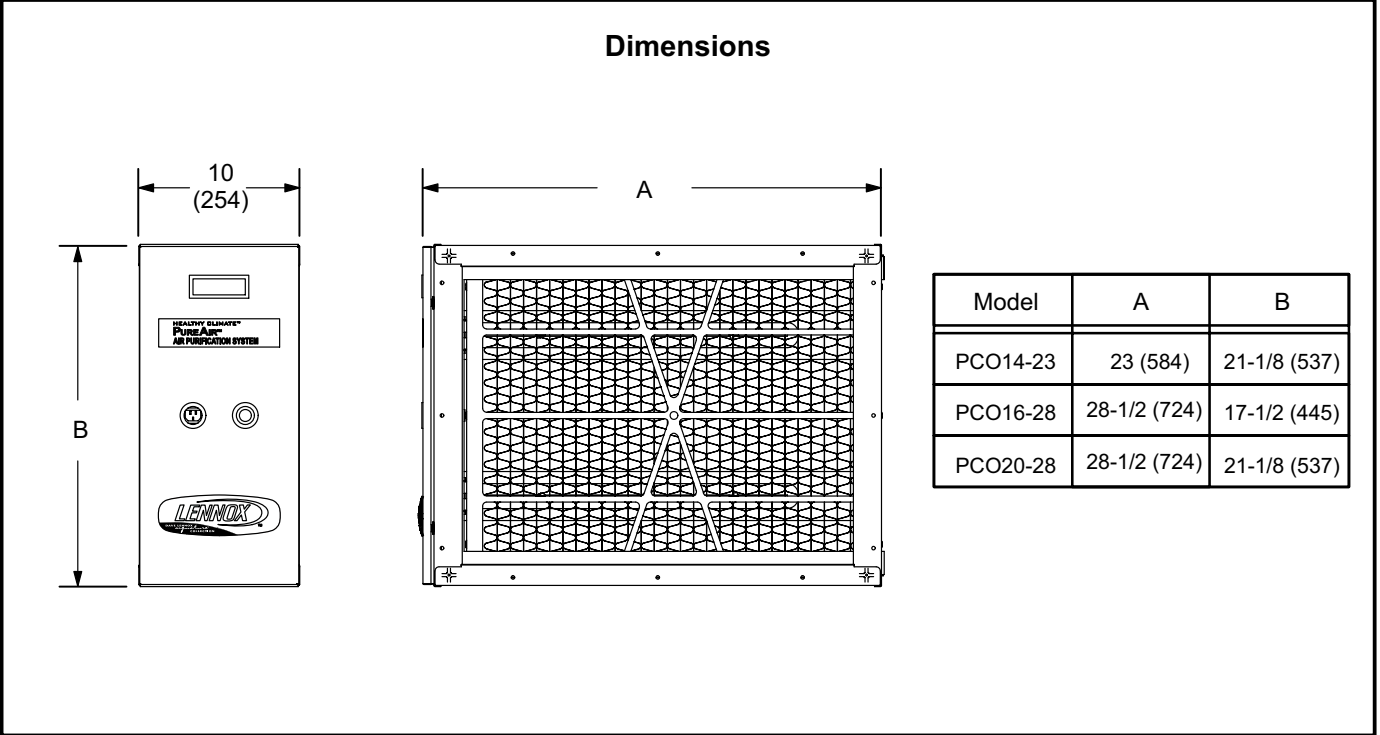

Figure 2

## Dimensions and Specifications



**Figure 3**

WEIGHT	
PCO14-23	34 lbs.
PCO16-28	36 lbs.
PCO20-28	39 lbs.
ELECTRICAL	
PCO14-23	120V, 50/60 Hz, 1.2 Amps -- Maximum, 230 V, 50/60 Hz, 0.65 Amps -- Maximum
PCO16-28	
PCO20-28	
POWER CONSUMPTION	
120VAC	144 Watts Nominal
230VAC	150 Watts Nominal
OPERATING ENVIRONMENT	
0°F to 140°F outside of duct. 10 to 60 percent relative humidity. (Optimal performance at 50 percent relative humidity)	

PLEATED FILTER EFFICIENCY	
Minimum Efficiency Rating Value (MERV) 16.	
LISTINGS	
ETL safety listing report 3061144A. Conforms to UL STD 1598. Certified to CSA STD C22.2 no. 250.0.	

Approximate Air Flow Resistance (Cabinet and Filter)				
Capacity (Tons)	Flow Rate (CFM)	Pressure Drop (in. w.g.)		
		PCO14-23	PCO16-28	PCO20-28
2	800	0.12	0.11	0.09
2.5	1000	0.17	0.15	0.12
3	1200	0.22	0.20	0.16
3.5	1400	0.28	0.25	0.19
4	1600	*	0.30	0.23
4.5	1800	*	*	0.28
5	2000	*	*	0.32

\*Not recommended. Excessive system pressure drop can damage HVAC system and reduce performance.

## Installation

### Select a Location

The PCO must be installed in the return air duct upstream of the supply blower. Allow a 30-inch service clearance in front of the access door as shown in figure 4. The control box, pleated filter and metal insert must be removable.

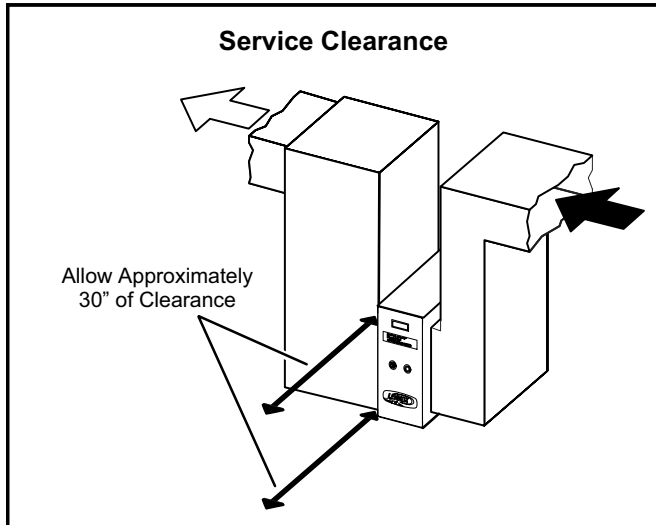

Figure 4

## NOTICE

The PCO should be installed in a horizontal position with the access panel facing to the front or rear. If the PCO must be installed in a vertical position with the access panel pointing upward and the lamps suspended vertically from the sockets, retaining clips are required to lock the lamps in the sockets. Contact the Technical Support Department at 1-800-953-6669 for additional information.

## NOTICE

This appliance is intended for return air duct installation only. Improper installation may damage PureAir™ system, HVAC system, or other equipment and may also void warranty.

### Remove Protective Wrapping

The metal insert is shipped in a protective vacuum packaging. Packaging must be removed prior to installation. Take care to prevent damage to metal insert when removing packaging.

## NOTICE

### Unpacking required.

**Remove all protective packing material from the UVA lamps and the titanium dioxide metal insert.**

**Packing material should be disposed of properly.**

Use cotton gloves or a cotton cloth to protect the lamps and your hands during unpacking and installation. Install lamps as follows:

- 1 - Remove the PCO access door.
- 2 - Slide out the control box assembly.
- 3 - Remove protective cardboard sleeves from lamp/reflector assembly.
- 4 - Ensure lamp is properly inserted in the lamp socket.
- 5 - If necessary, reseal lamp by gently engaging the pins in the socket and pivoting the lamp to engage the two securing clips mounted on the reflector.
- 6 - Gently pull on lamp to ensure that lamp securing clips are engaged.
- 7 - Repeat steps 3 through 6 to check installation for second lamp.
- 8 - Slide vacuum-packaged metal insert out of cabinet. Carefully remove insert from packaging.
- 9 - Keep metal insert and filter in a safe place to ensure these components remain clean until the cabinet installation is completed.

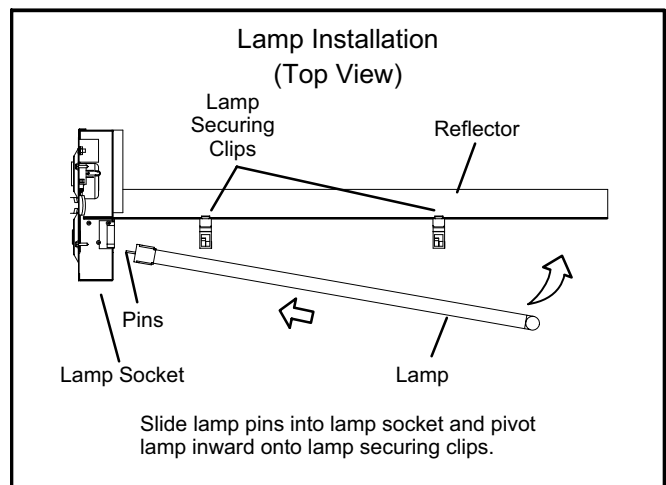

Figure 5

## CAUTION

**Lamps contain mercury.**

**Ingestion of or contact with mercury or mercury vapor is hazardous to your health.**

**Take care when handling lamps. If lamp is broken, avoid contact with mercury.**

## Installing PCO Cabinet

The PCO cabinet may either be installed on a level installation deck or platform adjacent to the air handler or it may be suspended from the rafters using metal strapping. If straps are used, take care when attaching straps to the PCO cabinet. Ensure fasteners do not interfere with internal components of the PCO cabinet. Filter, metal insert and control box must be able to slide freely into the cabinet.

- 1 - Oil on metal surfaces may cause odors. Use mild soap and water solution to wash all new duct and transition surfaces.
- 2 - Use the air flow directional label on the inside of the PCO cabinet to orient the PCO unit. Properly position the PCO cabinet next to the return air opening of the air handling unit. Use sheet metal screws (1" maximum length), rivets or other appropriate fasteners to secure PCO cabinet to the return air side of the air handling unit.
- 3 - Use sheet metal screws (1" maximum length) to fasten the return air duct to the other side of the PCO cabinet.
- 4 - Use aluminum foil tape or water-based mastic to seal all joints between the PCO cabinet, air handler and duct.
- 5 - In high humidity applications, wrap PCO cabinet with 2" foil-faced insulation (foil on the outside) to prevent condensation.

### NOTICE

Oil on metal ducts may cause odors.  
Use a mild soap and water solution to remove oils from transitions and duct surfaces prior to installation.

### NOTICE

Do not use any form of silicone sealant.  
Use of silicone-based products will reduce the effectiveness of or damage the titanium dioxide coatings on the metal insert.

### NOTICE

Route power cord away from traffic areas where the cord may become a safety hazard.

## Installing Filter and Metal Insert

Use the following procedure to install both filter and metal insert, see Figure 6.

- 1 - Slide the pleated filter into the rails on the air inlet side of the PCO cabinet. Verify proper air flow direction.
- 2 - Slide the metal insert into rails on the air outlet side of the PCO cabinet. Slide the control box assembly back into the cabinet.
- 3 - Securely fasten the access door.
- 4 - Plug one end of the provided power cord into the receptacle on the PCO cabinet and the other end into a power receptacle.
- 5 - Look through the view port in the access door to check to the lamps for proper illumination.

*NOTE - On initial start-up, the lamps may not reach full illumination for several minutes.*

### CAUTION

Ultraviolet (UV-A) radiation risk.  
Prolonged exposure may cause skin or eye damage.  
Avoid prolonged (weeks) exposure to skin or eyes.

### NOTICE

MERV 16 filters cannot tolerate direct exposure to UVA light.  
Filters are protected by factory-installed reflectors.

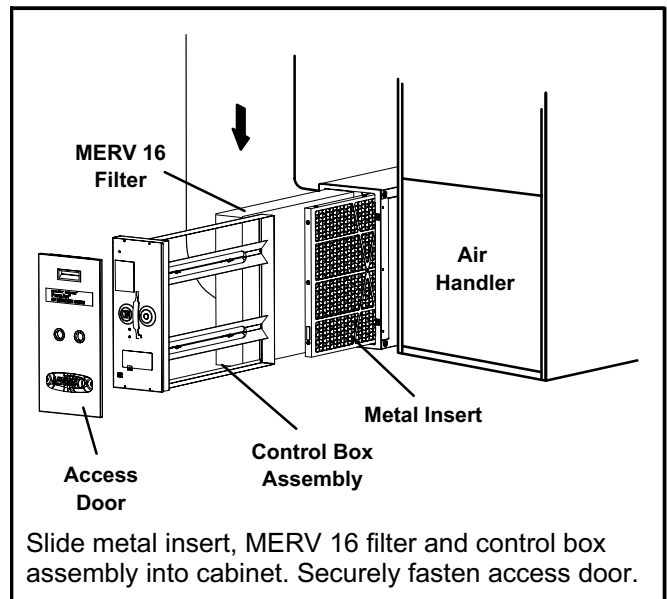

Figure 6

## Wiring

The PCO shall be wired in accordance with national and local codes.

# NOTICE

**UVA lamp life is shortened when lamps are turned off and on. Power to PCO unit must remain on at all times.**

**Do not interlock lamp operation with air handler blower operation.**

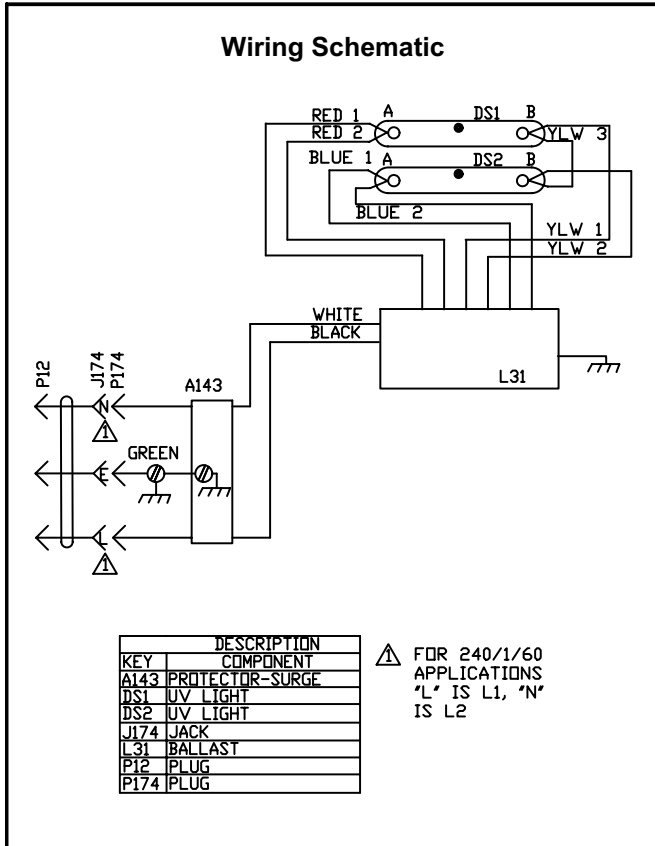

Figure 7

## Operation

1 - Check to ensure that access door is securely in place.

# ⚠ WARNING

**Risk of carbon monoxide poisoning.**

**Can cause injury or death.**

**Do not operate system unless access door is in place and properly secured. Operation of this equipment without the PCO access door in place may cause exhaust fumes to be drawn into occupied spaces.**

2 - Lamps should remain illuminated continuously except during service and maintenance.

3 - For optimal odor control, air handler blower should remain on continuously (thermostat fan setting in ON position, rather than AUTO).

If air handler does not provide a continuous low blower speed option, an additional blower relay should be installed. Use Lennox part number 45H03. Phone Lennox Application Department at 1-800-453-6669 for wiring information. Lennox units which include the SureLight® integrated control do not require the use of an additional relay.

*NOTE - Continuous fan operation may result in higher humidity. If humidity levels are uncomfortably high, fan setting should be switched to AUTO during cooling operation.*

## Filter, Insert and Lamp Replacement

The PCO MERV 16 filter, metal insert and UVA lamps require annual replacement. More frequent replacement may be required in applications with heavier dust or dirt loads or if you notice a reduction in odor-removal efficiency. An annual maintenance kit, which includes a replacement MERV 16 filter, a replacement metal insert and two replacement UVA lamps, is available through Lennox (See "Annual Maintenance Kit" for applicable kit part number.)

# ⚠ WARNING

**Electric shock hazard.**

**Can cause injury or death.**

**Disconnect all electrical power supplies before servicing.**

# ⚠ CAUTION

**Personal Burn Hazard.**

**Lamps become very hot when illuminated.**

**Allow lamps to cool for 10 minutes before removing lamp from socket.**

**Injury may result from contact with hot lamps.**

1 - Unpack the replacement MERV 16 filter, UVA lamps and metal insert which are provided in the Replacement Kit. Remove all protective wrapping materials.

2 - Unplug the power cord and remove the PCO access door.

3 - Slide out the control box assembly and remove the existing MERV 16 filter.

4 - Check air flow direction of the MERV 16 filter and insert replacement filter into the PCO cabinet.

5 - Remove the existing metal insert from the cabinet.

6 - Check air flow direction of the replacement metal insert and slide the metal insert into the cabinet.

- 7 - Wipe down reflectors using cotton cloth to remove finger prints and contaminants.
- 8 - Pivot the lamp away from the reflector until lamp is released from the securing clips. Gently pull lamp out of the lamp socket taking care not to break the lamp.
- 9 - Remove one replacement lamp from the box. Position the lamp with the pin end closest to the lamp socket. While engaging the pins in the socket, pivot the lamp so that the securing clips on the reflector lock into the open space in the middle of the lamp. See figure 5.
- 10 - **Gently pull on lamp to ensure that lamp securing clips are engaged.**
- 11 - Repeat steps 8 and 9 to replace second lamp.
- 12 - Slide control box assembly back into PCO cabinet.
- 13 - Securely fasten access door and reconnect power cord.
- 14 - Look through the view port in the access door to check to the lamps for proper illumination.

*NOTE - On initial start-up, the lamps may not reach full illumination for several minutes.*

## NOTICE

**Do not wash metal insert. Soap and water will destroy the titanium dioxide catalyst that coats the insert surface.**

## NOTICE

**If the system has been operated for a period of time without the lamps being illuminated, an odor may occur when lamps are illuminated. This odor is considered typical and should dissipate within 12 hours of full operation. If the odor does not subside after 48 hours of operation, instruct the homeowner to unplug the PCO unit and contact a Lennox dealer.**

## ⚠ CAUTION

### LAMPS CONTAIN MERCURY.

**Ingestion of or contact with mercury or mercury vapor is hazardous to your health.**

**Take care when handling lamps. If lamp breaks, avoid contact with mercury.**

## NOTICE

**Hg -- Lamps contain mercury.**

**Manage in accord with disposal laws.**

**Refer to [www.lamprecycle.org](http://www.lamprecycle.org) or call 1-800-9LENNOX.**

## Proper Clean-Up of Broken UVA Lamps

If a lamp is broken, it must be disposed of properly.

- Wear protective gloves, eye wear and mask.
- Sweep broken glass and debris into a plastic bag. Seal the bag and dispose of according to instructions given by local waste management office.
- **Do not use a vacuum cleaner. Do not incinerate.**

## Annual Maintenance Kits

The Annual Maintenance Kits include one MERV 16 filter, one metal insert and two lamps. Kit part numbers are as follows:

Part Description	Part Number		
	PCO14-23	PCO16-28	PCO20-28
Annual Maintenance Kit	X8797	X8796	X8795

## Replacement Parts

Replacement parts are available through Lennox, see figure 1 for parts arrangement. Part description and numbers are as follows:

Part Description	Part Number		
	PCO14-23	PCO16-28	PCO20-28
Cabinet	X8917	X8916	X8915
Access Door	X8920	X8919	X8918
Control Box Assembly	X8923	X8922	X8921
UVA Lamp	X8794	X8794	X8794
Electrical Socket	75X77	75X77	75X77
Lamp Socket	X8799	X8799	X8799
Reflector	X8926	X8925	X8924
Lamp Securing Clip	X8927	X8927	X8927
Surge Protector	X8928	X8928	X8928
Ballast	X8798	X8798	X8798
Metal Insert	X8793	X8792	X8791
MERV 16 Filter	X8790	X8789	X8788
Power Cord (120VAC)	49M48	49M48	49M48
Power Cord (230VAC)	91X44	91X44	91X44

# Troubleshooting Flow Chart

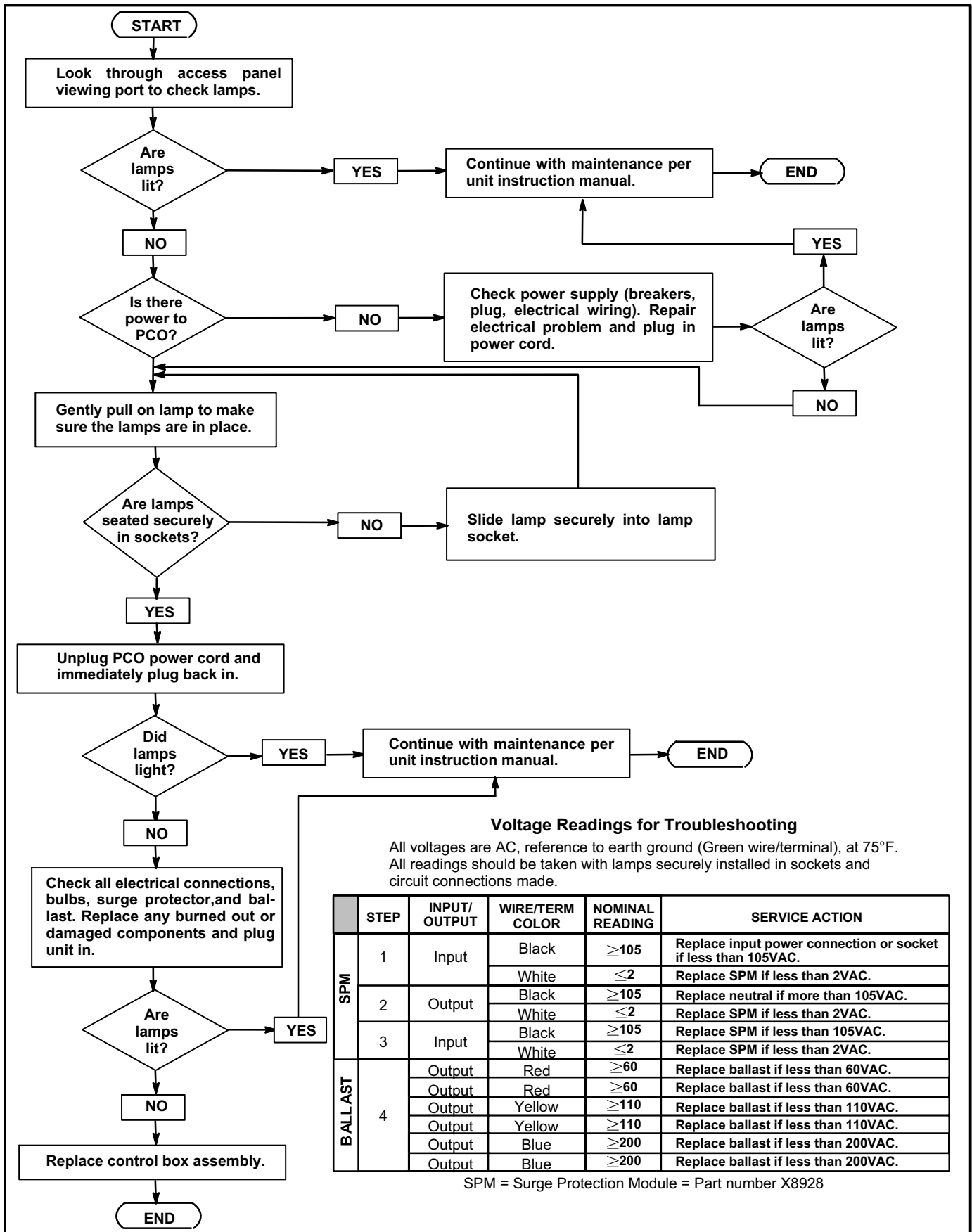

### Voltage Readings for Troubleshooting

All voltages are AC, reference to earth ground (Green wire/terminal), at 75°F. All readings should be taken with lamps securely installed in sockets and circuit connections made.

	STEP	INPUT/OUTPUT	WIRE/TERM COLOR	NOMINAL READING	SERVICE ACTION
SPM	1	Input	Black	$\geq 105$	Replace input power connection or socket if less than 105VAC.
			White	$\leq 2$	Replace SPM if less than 2VAC.
	2	Output	Black	$\geq 105$	Replace neutral if more than 105VAC.
			White	$\leq 2$	Replace SPM if less than 2VAC.
BALLAST	3	Input	Black	$\geq 105$	Replace SPM if less than 105VAC.
			White	$\leq 2$	Replace SPM if less than 2VAC.
	4	Output	Red	$\geq 60$	Replace ballast if less than 60VAC.
			Red	$\geq 60$	Replace ballast if less than 60VAC.
		Output	Yellow	$\geq 110$	Replace ballast if less than 110VAC.
			Yellow	$\geq 110$	Replace ballast if less than 110VAC.
Output	Blue	$\geq 200$	Replace ballast if less than 200VAC.		
	Blue	$\geq 200$	Replace ballast if less than 200VAC.		

SPM = Surge Protection Module = Part number X8928

Figure 8