



507477-01
4/2015
Supersedes 3/2015

PUREAIR™ AIR PURIFICATION SYSTEM PHOTOCATALYTIC OXIDATION (PCO) TECHNOLOGY

INSTALLATION INSTRUCTIONS FOR PUREAIR™ AIR PURIFICATION SYSTEM MODELS PCO3-14-16, PCO3-16-16 AND PCO3-20-16

THIS MANUAL MUST BE LEFT WITH THE HOMEOWNER FOR FUTURE REFERENCE

Shipping & Packing List

Assembled PureAir™ air purification system which includes:

- Cabinet (1)
- UVA Lampholder / PCO cartridge (secure to interior of cabinet) (1)
- UVA lamp in box (secure to interior of cabinet) (1)
- Healthy Climate® Carbon Clean 16 Filter (located in interior of cabinet) (1)
- UVA lamp socket with 4-pin female connector assembly attached to light ballast electrical connector (1)
- Literature Bag includes power cord (120VAC)*, installation instruction, UVA Lamp Socket brass finger nuts (2), UVA Lampholder / PCO cartridge wing nuts (2) and warranty.

*230VAC power cord available separately (part number 91X44).

Shipping Damage

Check equipment for shipping damage. If damage is found, immediately contact last carrier.

General Information

The PureAir™ air purification system uses photo-catalytic oxidation (PCO) technology to reduce levels of airborne volatile organic compounds, cooking odors, common household odors, airborne dust particles, mold spores and pollen. The PureAir™ air purification system is available in three models (PCO3-14-16, PCO3-16-16 and PCO3-20-16). Each unit may be connected to either 120VAC or 230VAC power supply.

Lab tests confirm a 50% reduction in **total volatile organic compounds (TVOC)** within the first 24 hours of initial operation of the PureAir™ air purification system. It may take up to 48 hours after initial system start-up to reduce the airborne chemicals that have built up in a home over a long period of time.

For peak performance, unit should be installed in homes with TVOC levels that are less than 1000 micro-gram / cubic meter. Home source removal and ventilation may be required to lower total volatile organic compounds to this level.

The Healthy Climate® Carbon Clean 16 Filter combines industry-leading MERV 16 filtration and carbon-coated fiber matrix.

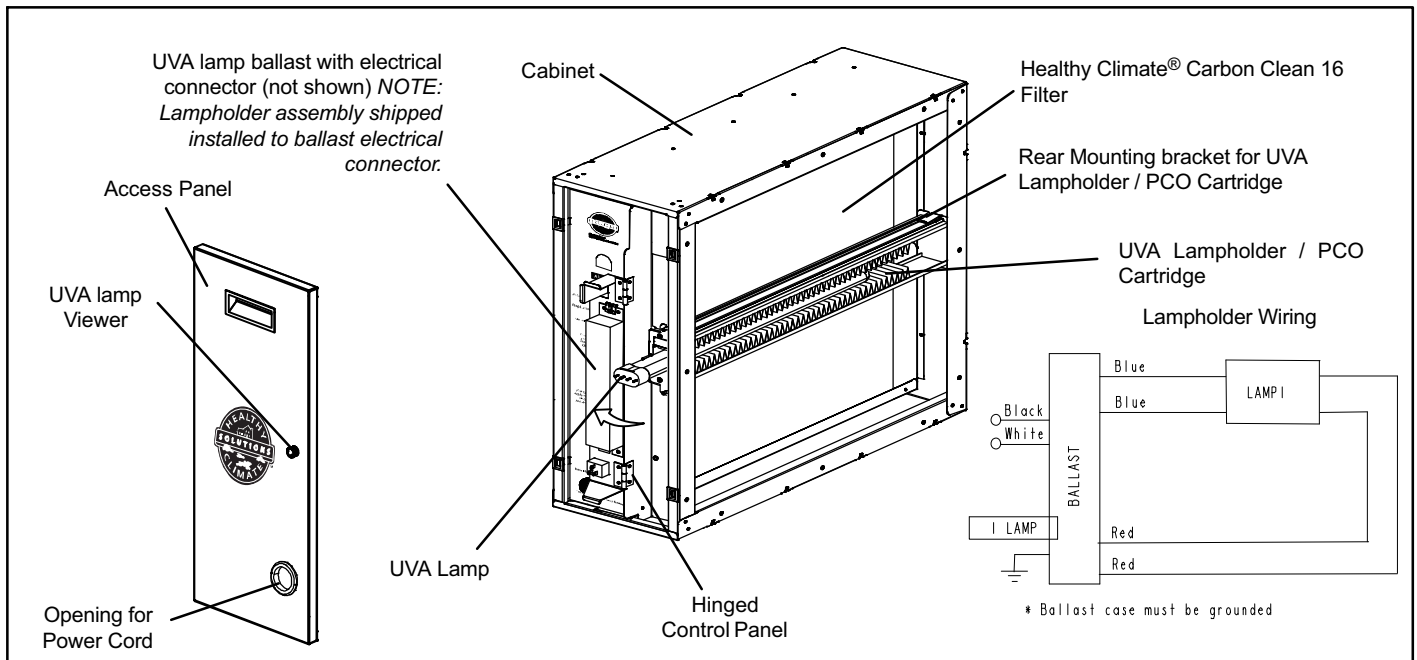

Figure 1. Parts Identification



Dimensions and Specifications

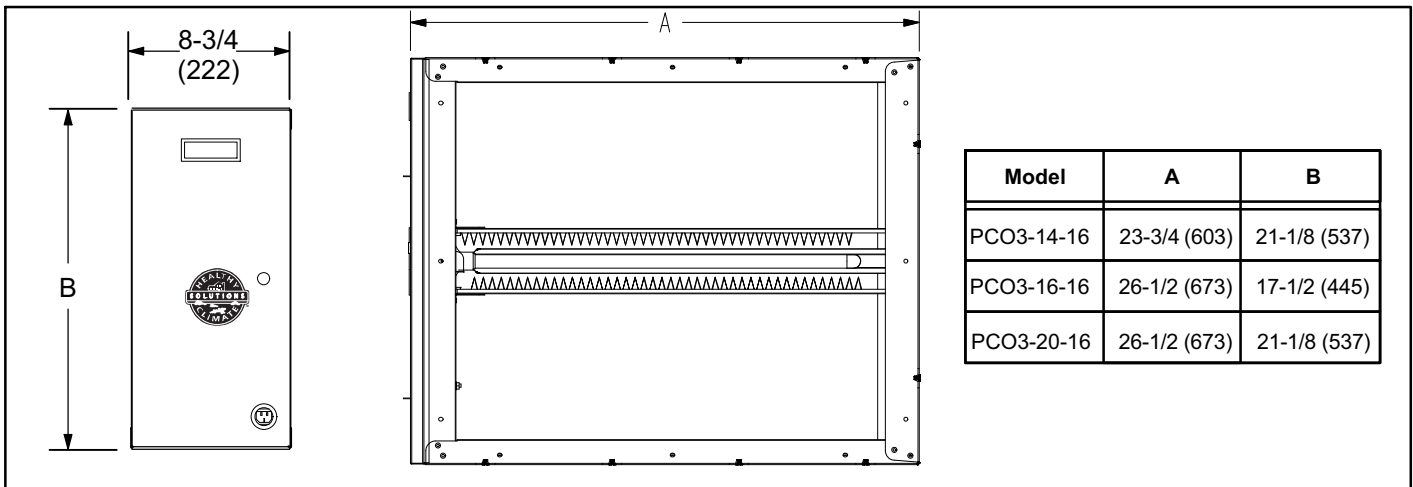

Figure 2. Dimensions

Table 1. Specifications

WEIGHT	
PCO3-14-16	27 lbs.
PCO3-16-16	25 lbs.
PCO3-20-16	27 lbs.
ELECTRICAL	
PCO3-14-16	120V, 50/60 Hz, 0.48 Amps -- Maximum
PCO3-16-16	230 V, 50/60 Hz, 0.24 Amps -- Maximum
PCO3-20-16	
POWER CONSUMPTION	
120VAC	58 Watts Nominal
230VAC	58 Watts Nominal
OPERATING ENVIRONMENT	
0°F to 140°F outside of duct 10 to 60 percent relative humidity (Optimal performance at 50 percent relative humidity)	
PLEATED FILTER EFFICIENCY	
Minimum Efficiency Rating Value (MERV) 16	
LISTINGS	
ETL safety listing report 3061144A. Conforms to UL STD 1598 Certified to CSA STD C22.2 no. 250.0.	

Table 2. Approximate Air Flow Resistance
(Cabinet and Filter)

Capacity (Tons)	Flow Rate (CFM)	Pressure Drop (in. w.g.)		
		PCO3-14-16	PCO3-16-16	PCO3-20-16
Low / Variable	400	0.05	0.04	0.03
Low / Variable	600	0.07	0.07	0.06
2	800	0.11	0.11	0.08
2.5	1000	0.15	0.15	0.11
3	1200	0.20	0.20	0.15
3.5	1400	0.25	0.25	0.18
4	1600	*	0.31	0.22
4.5	1800	*	*	0.27
5	2000	*	*	0.31

*Not recommended. Excessive system pressure drop can damage HVAC system and reduce performance.

⚠ WARNING

Risk of property damage, injury, or death.

Installation and service must be performed by a licensed professional installer (or equivalent) or a service agency.

⚠ WARNING

Risk of carbon monoxide poisoning.

Can cause injury or death.

Do not operate system unless access panel is in place and properly secured. Operation of this equipment without the access panel in place may cause exhaust fumes to be drawn into occupied spaces.

⚠ WARNING

Electric shock hazard.
Can cause injury or death.
Disconnect all electrical power supplies before servicing.
Access panels must be in place during appliance operation.

⚠ CAUTION

Sharp edges hazard.
Sharp edges can cause injuries.
Use protective gloves when grasping equipment edges.

⚠ CAUTION

UVA Lamp contains mercury.
Ingestion of or contact with mercury or mercury vapor is hazardous to your health.
Take care when handling UVA lamp. If UVA lamp is broken, avoid contact with mercury.

⚠ CAUTION

Ultraviolet (UVA) radiation risk.
Prolonged exposure may cause skin or eye damage.
Avoid prolonged (weeks) exposure to skin or eyes.

⚠ CAUTION

Personal Burn Hazard.
UVA lamp is very hot when illuminated.
Allow lamp to cool for 10 minutes before removing lamp from socket.
Injury may result from contact with hot UVA lamp.

⚠ CAUTION

LAMP CONTAIN MERCURY.
Ingestion of or contact with mercury or mercury vapor is hazardous to your health.
Take care when handling UVA lamp. If UVA lamp breaks, avoid contact with mercury.

NOTICE

Possible odor emissions. Chemical reactions may cause temporary odors after initial start-up or after lamp replacement. Odor may also be present after paint, cleaning solutions or hobby materials have been used in the conditioned space.

Some occupants may experience irritation or discomfort during this period. If the irritation or discomfort lasts longer than 48 hours, the homeowner should be advised to contact a Lennox dealer.

NOTICE

The cabinet should be installed so that the UVA lamp will be in the horizontal position.

Contact the Technical Support Department at 1-800-953-6669 for additional information.

NOTICE

This system is NOT intended to be used for removal of active mold growth or continuous sources of high levels of chemicals in the air.

For existing mold growth, the mold must be properly removed PRIOR to installation of the PureAir™ air purification system.

NOTICE

This appliance is intended for return air duct installation only.

Improper installation may damage PureAir™ air purification system, HVAC system, or other equipment and may also void warranty.

NOTICE

Oil on metal ducts may cause odors.
Use a mild soap and water solution to remove oils from transitions and duct surfaces prior to installation.

NOTICE

Do not use any form of silicone sealant.
Use of silicone-based products will reduce the effectiveness of, or damage the titanium dioxide coatings on the PCO cartridge.

NOTICE

Route power cord away from traffic areas where the cord may become a safety hazard.

NOTICE

Healthy Climate® Carbon Clean 16 Filter cannot tolerate direct exposure to UVA light.
Filter is protected by PCO cartridge shield.

NOTICE

Unpacking required.
Remove all protective packing material from the UVA lamp (taped to the cabinet) and the titanium dioxide PCO cartridge.
Packing material should be disposed of properly.

NOTICE

UVA lamp life is shortened when lamp is turned off and on. Power to unit must remain on at all times.
Do not interlock lamp operation with air handler blower operation.

NOTICE

Do not wash UVA Lampholder / PCO cartridge. Soap and water will destroy the titanium dioxide catalyst that coats the cartridge surface.

Installation Examples

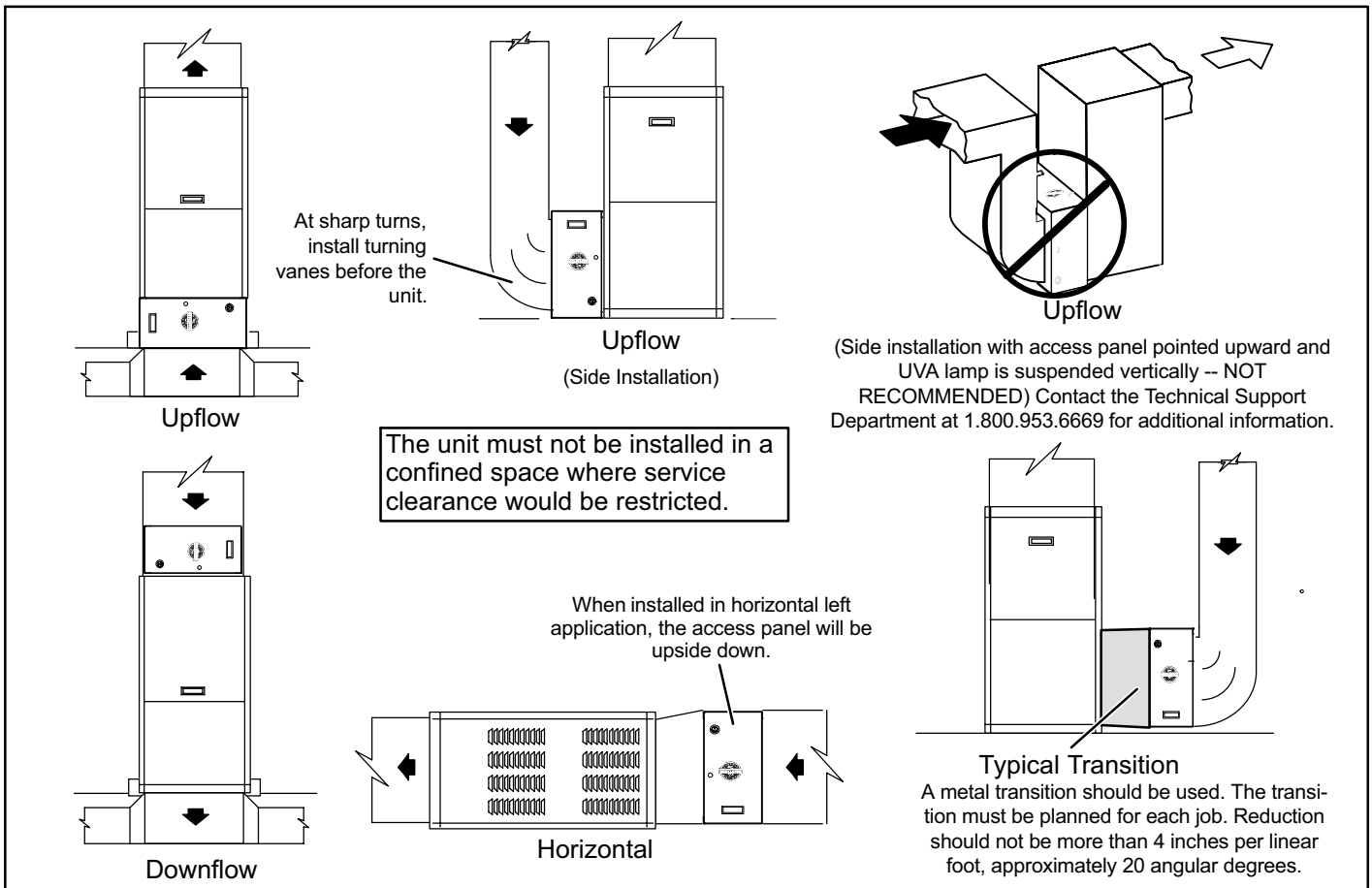

Figure 3. Installation Examples

Unique Field-Supplied Installation Items

- Cotton gloves and cloth (to remove finger prints from UVA lamp)
- Aluminum foil tape or water-based mastic (NOT silicone) to be applied as a sealant.

Installation

Select a Location

The unit must be installed in the return air duct upstream of the supply blower. Allow a 30-inch service clearance in front of the access panel as shown in figure 4. The air filter and UVA Lampholder / PCO cartridge must be removable.

Installing Cabinet

The cabinet may either be installed on a level installation deck or platform adjacent to the air handler or it may be suspended from the rafters using metal strapping. If straps are used, take care when attaching straps to the cabinet. Ensure fasteners do not interfere with internal components of the cabinet. The air filter and UVA Lampholder / PCO cartridge must be able to slide freely into the cabinet.

1. Locate and remove the UVA Lampholder / PCO cartridge from the cabinet.

NOTE: Oil on metal surfaces may cause odors. Use mild soap and water solution to wash all new duct and transition surfaces.

2. Use the air flow directional label on the inside of the UVA Lampholder / PCO cartridge to orient the unit.
3. Properly position the cabinet next to the return air opening of the air handling unit. Use sheet metal screws (1" maximum length), rivets or other appropriate fasteners to secure cabinet to the return air side of the air handling unit.
4. Use field-provided sheet metal screws (1" maximum length) to fasten the return air duct to the other side of the cabinet. Attachment holes are provided in housing.

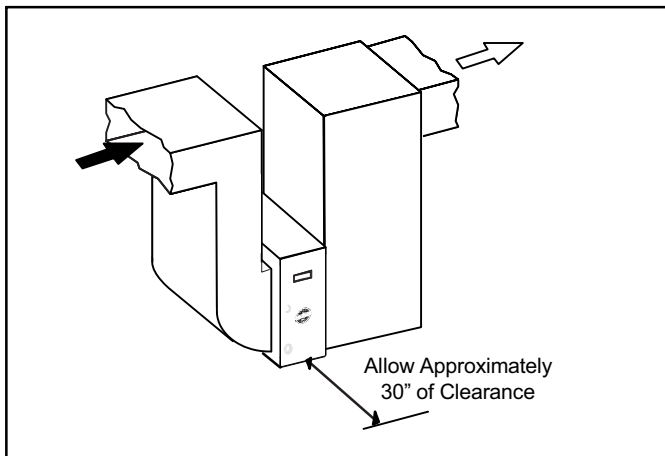

Figure 4. Service Clearance

5. Use field-provided aluminum foil tape or water-based mastic to seal all joints between the cabinet, air handler and duct.
6. In high humidity applications, wrap cabinet with field-provided 2" foil-faced insulation (foil on the outside) to prevent condensation.

UVA Lamp Installation

Use cotton gloves or a cotton cloth to protect the lamp and your hands during unpacking and installation.

1. Remove cabinet access panel.
2. The UVA Lampholder / PCO cartridge is shipped in a protective packaging. Packaging must be removed prior to installation. Take care to prevent damage while removing from packaging.
3. Locate the UVA lamp box, which is taped to the inside of cabinet and carefully remove. Set UVA lamp box

aside while preparing cabinet for UVA lamp installation.

4. Remove (slide out) Healthy Climate® Carbon Clean 16 Filter from cabinet.
5. Disconnect the lampholder cable assembly from the UVA lamp ballast connector.
6. Secure the UVA lamp electrical connector to the UVA lamp by sliding the UVA lamp pins into the slot. Proper connection will make a snapping sound.

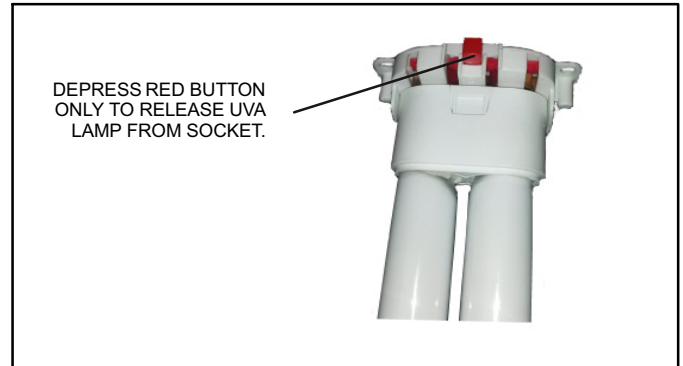

7. Slide the UVA lamp into UVA Lampholder / PCO cartridge. Verify that the UVA lamp is secure to the one metal UVA lamp clamp located mid-way on the UVA lamp reflector.

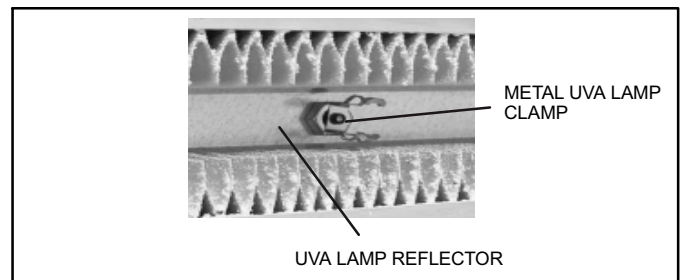

8. Rotate the hinged control panel assembly out.

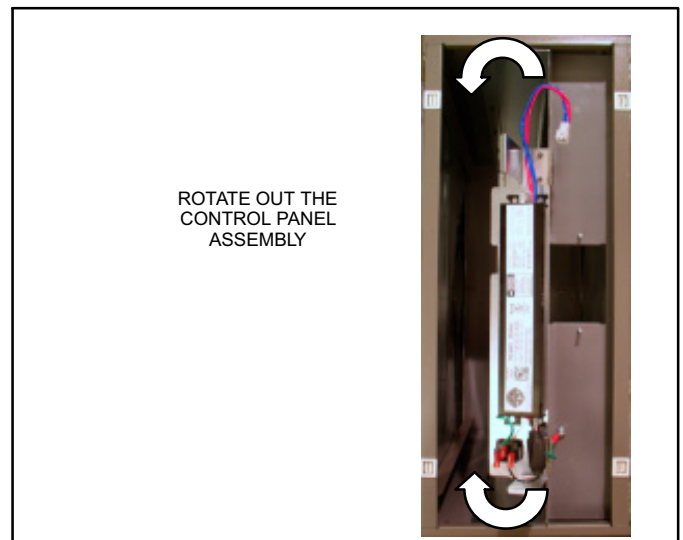

9. Thread the UVA Lampholder / PCO cartridge two posts through the UVA lamp connector's two holes

10. Fasten the lamp socket to the UVA Lampholder / PCO cartridge using the two-brass figure nuts located in the literature bag.

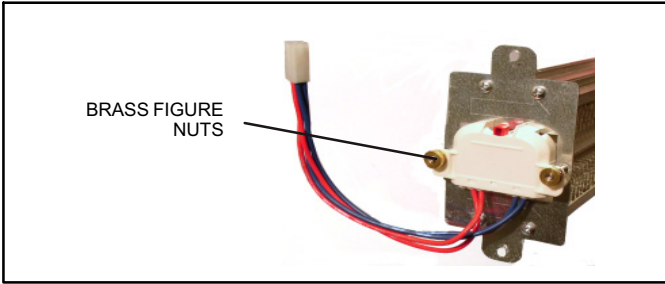

Installing UVA Lampholder

Use the following procedure to install the UVA Lampholder / PCO cartridge.

1. While aligning, slide the UVA Lampholder / PCO cartridge into case rails and align with rear mounting bracket.
2. Secure the UVA Lampholder / PCO cartridge to the two frame screw posts using the provided wing nuts (2).

NOTE: There is an arrow on the front of the component indicating the correct way to install it.

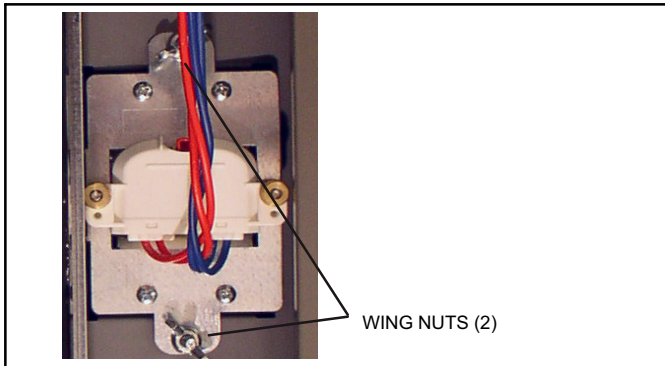

3. Connect UVA lamp 4-pin male connector to ballast female 4-pin connector.

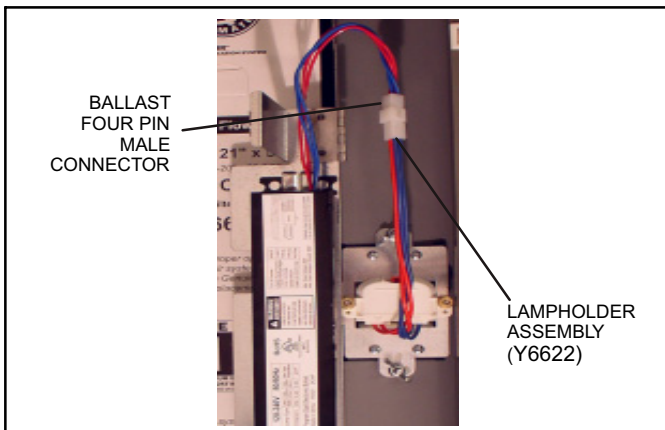

4. Rotate hinged control panel assembly back into the cabinet. Make sure no wiring is being pinched.

Installing Air Filter

Use the following procedure to install the air filter.

1. Slide the Healthy Climate® Carbon Clean 16 Filter into the rails on the air inlet side of the cabinet. Verify proper airflow direction.
2. Securely fasten the access panel.
3. Plug one end of the provided power cord into the receptacle on the cabinet and the other end into a power receptacle.
4. Look through the view port in the access panel to check that the UVA lamp is illuminated.

NOTE - On initial start-up, the UVA lamp may not reach full illumination for several minutes.

Wiring

The should be wired in accordance with national and local codes.

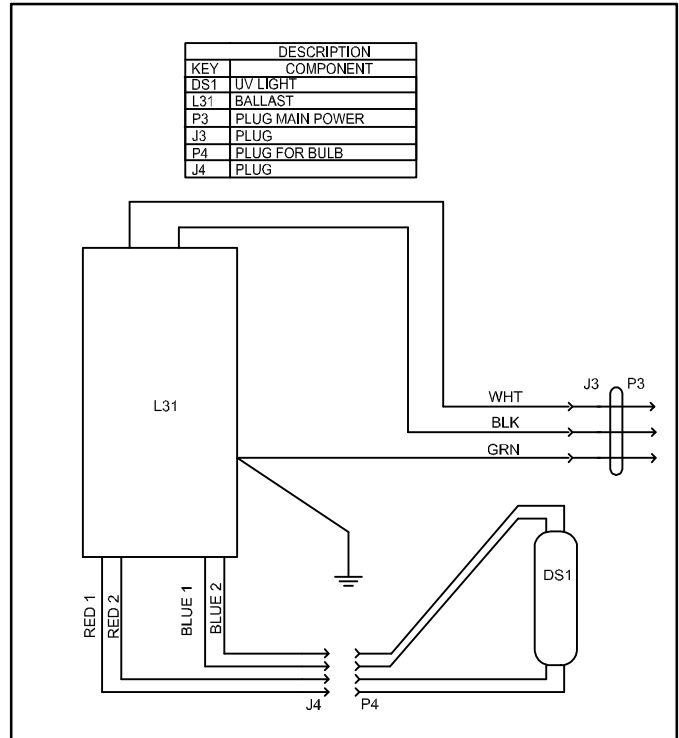

Figure 5. Wiring Schematic

Operation

NOTICE

If the system has been operated for a period of time without the UVA lamp being illuminated, an odor may occur when lamp is illuminated. This odor is considered typical and should dissipate within 12 hours of full operation. If the odor does not subside after 48 hours of operation, instruct the homeowner to unplug the unit and contact a Lennox dealer.

1. Check to ensure that access panel is securely in place.
2. Lamp should remain illuminated continuously except during service and maintenance.
3. For optimal odor control, air handler blower should remain on **CONTINUOUSLY** (thermostat fan setting in ON position, rather than AUTO).

If air handler does not provide a continuous low blower speed option, an additional blower relay should be installed. Use Lennox part number 45H03. Contact the Lennox Application Department at 1-800-453-6669 for wiring information.

NOTE - Continuous fan operation may result in higher humidity. If humidity levels are uncomfortably high, fan setting should be switched to AUTO during cooling operation.

Filter, UVA Lampholder / PCO Cartridge and UVA Lamp Replacement

The Healthy Climate® Carbon Clean 16 Filter, UVA Lampholder / PCO cartridge and UVA lamp require annual replacement. More frequent filter replacement may be required in applications with heavier dust or dirt loads or if you notice a reduction in odor-removal efficiency. An annual maintenance kit is available.

Annual Maintenance Kits

The annual maintenance kits include the following:

- Healthy Climate® Carbon Clean 16 Filter (1)
- PCO cartridge (1)
- UVA lamp (1)

Order using the following kit catalog numbers:

Table 3. Maintenance Kits

Part Description	Catalog Numbers		
	PCO3-14-16	PCO3-16-16	PCO3-20-16
Annual Maintenance Kit	Y6616	Y6612	Y6608

Replacement Parts

Replacement parts are available through Lennox, see figure 1 for parts arrangement. Part description and catalog numbers are as follows:

Part Description	Catalog Numbers		
	PCO3-14-16	PCO3-16-16	PCO3-20-16
Healthy Climate® Carbon Clean 16 Filter	Y6606	Y6605	Y6604
UVA Lamp	X8794	X8794	X8794
PCO cartridge	Y6621	Y6607	Y6607
Lampholder Assembly	Y6622	Y6622	Y6622
Power Cord (120VAC)	49M48	49M48	49M48
Power Cord (230VAC)	91X44	91X44	91X44
Electrical Socket	75X77	75X77	75X77
Ballast	Y6620	Y6620	Y6620

Removing and Installing UVA Lamp, Lampholder and Air Filter

1. Remove power cord from 120VAC or 230VAC receptacle.
2. Remove power cord from unit
3. Remove access panel.
4. Remove Healthy Climate® Carbon Clean 16 Filter.
5. Rotate out the hinged control panel.
6. Disconnect UVA lamp electrical connector from ballast.
7. Remove both fasteners securing the UVA Lampholder / PCO cartridge from the chassis.
8. Slide out the UVA Lampholder / PCO cartridge from the chassis.
9. Remove both brass figure nuts that secure the UVA lamp elector connector to the UVA Lampholder / PCO cartridge.
10. Slide out UVA lamp from UVA Lampholder / PCO cartridge.
11. Push the red button on UVA lamp electrical connector and gently slide off connector from UVA lamp (do not dispose of UVA lamp electrical connector).
12. Properly dispose of UVA lamp and air filter
13. Reinstall in reverse order starting with step 11.

Proper Clean-Up of Broken UVA Lamp

If UVA lamp is broken, it must be disposed of properly.

- Wear protective gloves, eye wear and mask.
- Sweep broken glass and debris into a plastic bag and seal before disposal in accordance with instructions provided by local waste management office.
- **Do not use a vacuum cleaner. Do not incinerate.**

NOTICE

Hg -- UVA Lamp contain mercury.
 Manage in accord with disposal laws.
 Refer to www.lamprecycle.org or call
 1-800-9LENNOX.

Troubleshooting Flow Chart

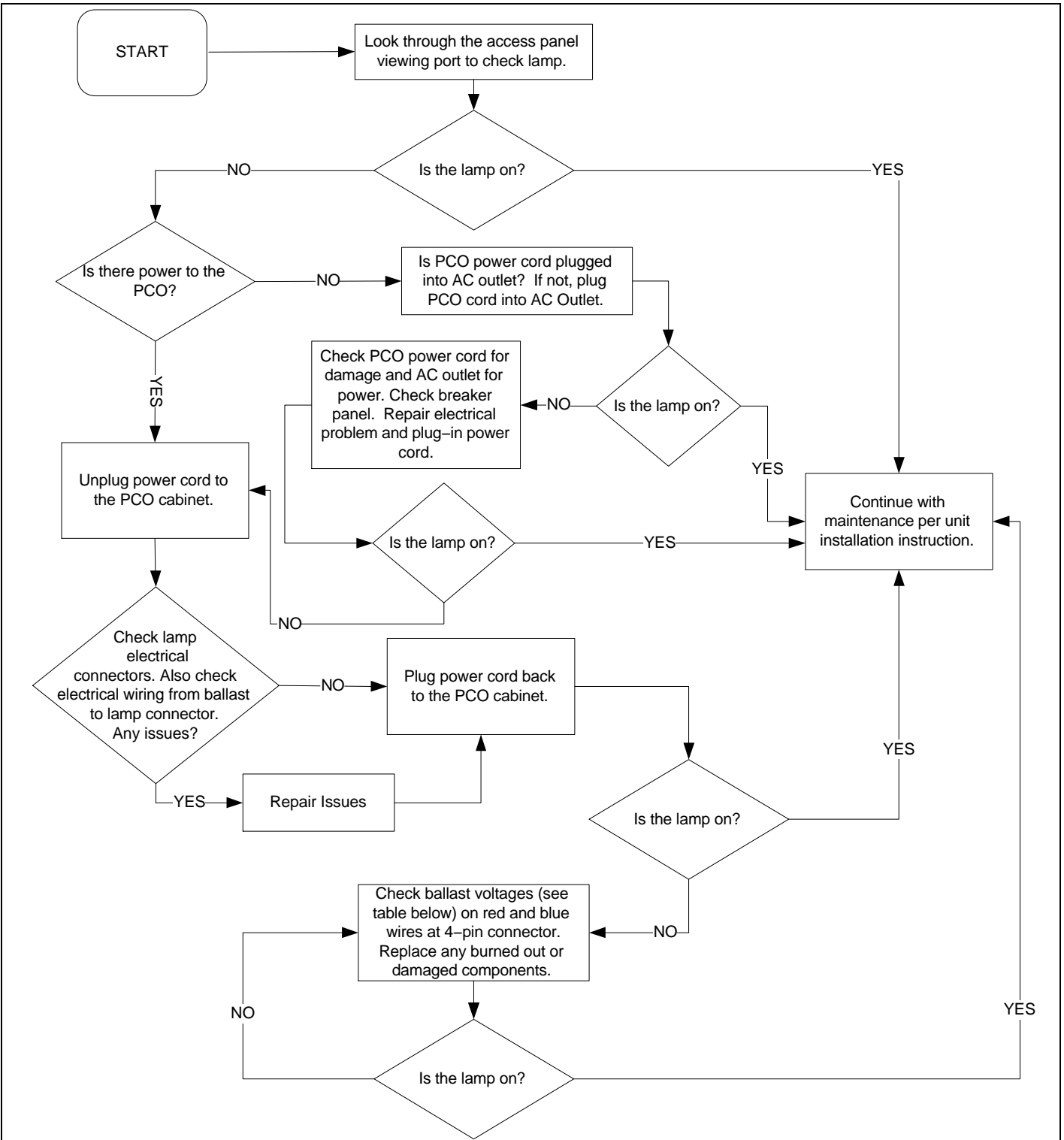

	INPUT/OUTPUT	WIRE/TERM COLOR	NORMAL READING	SERVICE ACTION (See wiring diagram, Figure 5, Page 6)
BALLAST	OUTPUT	RED	≥60	Replace ballast if less than 60VAC.
		RED	≥60	Replace ballast if less than 60VAC.
		BLUE	≥200	Replace ballast if less than 200VAC.
		BLUE	≥200	Replace ballast if less than 200VAC.

Figure 6. Troubleshooting Flow Chart