

Direct Drive Damper Actuator M847D

Application

The M847D is a two position, 24 Vac spring return damper actuator designed to operate directly driven zone dampers, used to control air flow in ducts. The synchronous motor actuator can be driven open (or closed) using any 24 volt rated two position switch - eg. a wall switch or a thermostat subbase switch.

The M847D replaces the RDMH and RDMZ damper actuators for use on Trol-A-Temp® ARD and ZD dampers.

Specifications

Electrical Rating: 24 Vac 60 Hz 0.32 Amp., 8 VA

Electrical Connection: 1/2" conduit

Nominal Angular Rotation: 90° (max. 105°)

Torque: Min. 423 mNm (milli newton meter) [60 in.oz] output torque available when motor is energized and device is at the spring returned initial start position.

Nominal Motor Timing: (@25°C ambient)

Energized at rated load - 30 seconds.

De-energized (spring return) - 10 seconds.

Ambient Temperature Rating: 5 to 60°C (+40 to 140°F)

Finish: zinc plated steel, anodized aluminium

Direction of Shaft Rotation: clockwise, when energized and viewed from the base or shaft end.

Mounting Means: direct connection to damper shaft.

Mounting Position: Multi-poise.

Dimensions: See Figure 1.

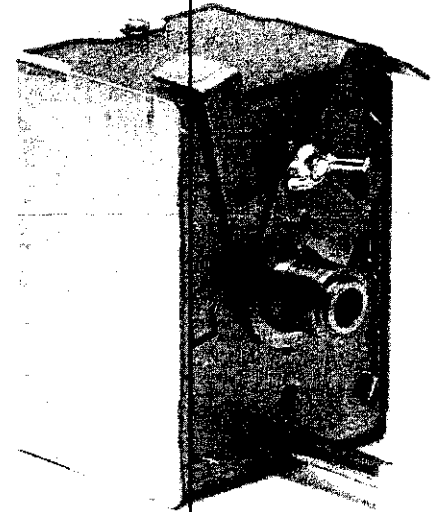

Nominal Device Dimension

	A	B	C	D	E	F
mm	60	84.5	88	8.2	31.5	19.3
in	2-3/8	3-3/8	3-1/2	5/16	1-1/4	3/4

	G	H	J	K	L	M
mm	15.8	58.6	29.3	33.5	6.4	40.4
in	5/8	2-5/16	1-3/16	1-5/16	1/4	1-9/16

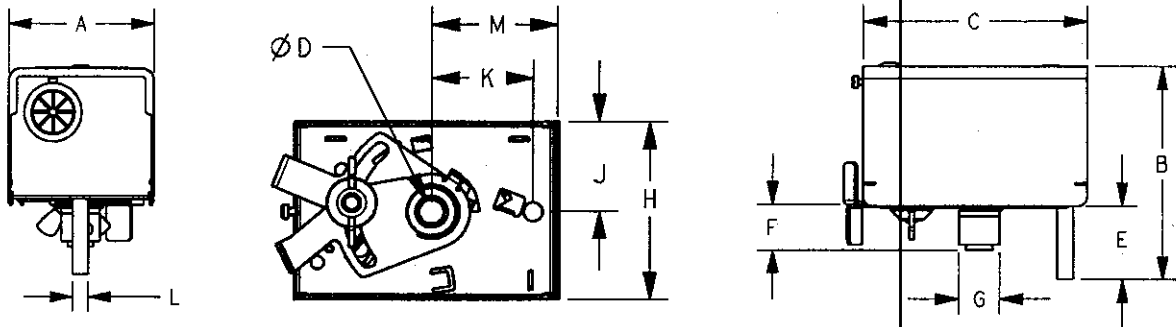

Fig. 1 - Dimensional Details

INSTALLATION AND CHECKOUT

⚠ CAUTION

1. Read these instructions carefully. Failure to follow them could cause a hazardous condition.
2. Disconnect powersupply before beginning of installation and wiring of control to prevent electrical shock or equipment damage.
3. Check the ratings given in the instructions and on the product to make sure the product is suitable for your application.
4. All wiring must comply with local electrical codes, ordinances, and regulations.
5. Installer must be a trained, experienced service technician.
6. After installation is complete, check out the product operation as provided in these instructions.

WARNING

1. DO NOT install this actuator on a flue damper.
2. DO NOT attempt to rotate the actuator by turning the connection coupling or the damper shaft when it is connected to the actuator or damage to the gear train may occur.

STANDARD MOUNTING (For 5/16" dia. damper shaft)

The M847D can be attached directly to the protruding 5/16" diameter damper shaft using the sleeve of the output shaft. Drill A 5/16" (8mm) hole 1-5/16" (33.5mm) directly below the damper shaft opening to accept the anti-rotation shaft protruding from the base of the motor. The length of the damper shaft to which the connection coupling is attached is such as to firmly hold the actuator in a position to adequately engage the anti-rotation pin in the warm air duct. See Figure 1. for the critical dimensions.

M847D

INSTALLATION AND CHECKOUT CONTINUED

Replacing M847D on a Trol-A-Temp® ARD damper

1. Disconnect the motor wiring.
2. Using a 1/8 in. hex wrench to loosen the motor coupling from the blade shaft, remove the existing motor assembly.
3. Observe that the damper blades are in the normal, spring open or spring closed position.
4. Place the new motor onto the shaft and tighten the coupling.
5. Reconnect the motor wiring.

ALTERNATE MOUNTING (For 7/16" dia. coupling style dampers)

Before installing the M847D actuator to a damper with a 7/16" coupling, insert the drive shaft extension into the drive shaft and tighten with the set screw provided. See Fig. 2. Also install the anti-rotation extension to the end of the anti-rotation rod. Install the actuator on the damper and tighten the coupling screw.

Fig 2. For 7/16" COUPLING MODEL DAMPERS ONLY

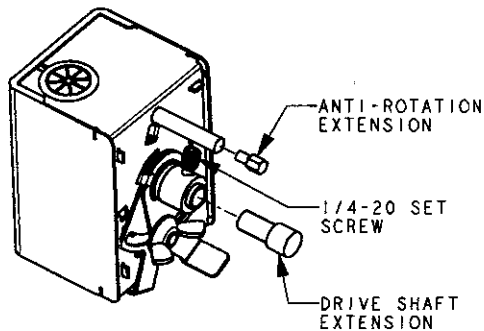

Replacing M847D on a Trol-A-Temp® ZDS or ZDB damper

1. Disconnect the motor wiring.
2. Using a 3/16 in. hex wrench to loosen the Allen screw located above the faceplate at the motor coupling.
3. Remove the existing motor.
4. Observe that the damper blades are in the open position with the setscrew pointing toward the damper label.
5. Attach the new motor to the coupling. Make sure that the standoff on the motor is positioned in the grommet on the faceplate.
6. Tighten the set screw.
7. Reconnect the motor wiring.

WIRING

See Figure 3. for typical wiring hook-ups of the M847D.

Figure 3 - Typical M847D Hookup

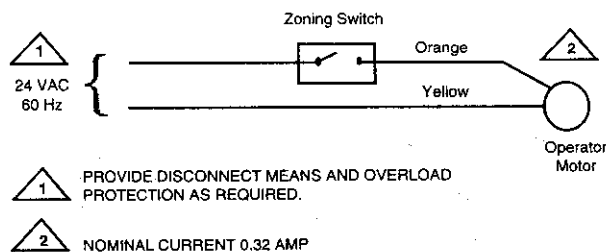

CHECKOUT

After completing the installation, check that the equipment operates correctly as follows:

1. When 24 Vac is applied to the motor leads, the motor powers to the closed or open position.
2. When power is removed, the motor releases and spring returns to the normal position.

If full opening and closing is not achieved, check the lower adjustment lever is to the extreme left and the upper lever is to the extreme right. See Fig. 4 (Air Flow Adjustments)

AIR FLOW ADJUSTMENTS

Note: The following describes the adjustments available with the actuator installed in the **power closed** mode. If the damper you are installing is to operate in the **power open** mode, the function of the upper and lower levers is reversed.

1. When viewed on end, the lower lever is normally positioned to the extreme left. (See Fig. 4) This position allows the damper to fully open 90° when de-energized.
2. To restrict the air flow in the open position, loosen (do not remove) the wing nut and move the lower lever to the right until the desired position is reached. Tighten the wing nut. In the extreme right position the damper should open approx. 50° with the power off.
3. The upper lever is normally positioned to the right to provide complete shut off when the actuator is energized. (See Fig. 4)
4. If desired, to prevent complete closure of the damper, loosen (do not remove) the wing nut on the bottom of the unit and move the upper lever to the left until the desired position is achieved. Tighten the wing nut. In the extreme left position the damper should close to approx. 40° with the power on.
5. If additional rotation is required beyond 90°, an additional 15° may be obtained by removing the Upper Lever. To do this, first, remove the actuator from the damper. Remove the wing nut and retaining ring then remove the levers. Reassemble and install.

Fig. 4 - Air Flow Adjustment

