

# MODELS LT15 & LT20



## INSTALLATION INSTRUCTION FOR HEAT RECOVERY VENTILATOR (HRV)

### Shipping and Packing List

#### Package 1 of 1 contains:

- 1 - Assembled ventilator
- 1 - Bag assembly containing:
  - 2 - Drain spout assemblies (*HRV units only*)
  - 4 - Hanging straps
  - 1 - Installation manual

### Required Tools

#### Installation Tools

- tin snips
- assorted screw drivers
- electric drill
- hammer
- wire strippers
- knife
- caulking gun
- smoke pencil
- large zip ties
- fabric flexible duct - class I rated
- mastic tape
- alum. foil duct tape
- zip ties
- 1/2" I.D. drain hose

#### Balancing Tools

- Pitot Tube Balancing Kit [Case, 8 ft. vinyl tubing, Pitot tube, magnehelic gauge (0 - 0.25"), and mounting plate]
- Pitot Tube with instructions and Digital Manometer (with resolution of 0 - 0.25" - must read to 1/100ths of an inch)

#### Optional Accessories

- 20 Minute Fan Timer
- Wall Mounted Dehumidistat
- Weather hood Kit
- Round Diffuser
  - 4" (100mm)
  - 6" (150mm)
  - 8" (200mm)
- Kitchen Grille
  - *may be required by code for kitchen applications*
  - *contains removable grease filter*

### Application

Heat Recovery Ventilators (HRV) are designed to provide fresh air while exhausting an equal amount of stale air.

The HRV is equipped with an aluminum core. The device uses the stale air that is being exhausted to condition the fresh air as it is being brought in.

### General

These instructions are intended as a general guide and do not supersede local codes in any way. Consult authorities who have jurisdiction before installation.

### Table of Contents

Shipping and Packaging List .....	1
Required Tools .....	1
Application .....	1
General .....	1
Engineering Data .....	2-3
Clearances & Requirements .....	4
Installation .....	4-7
Application Illustrations .....	8-10
Electrical .....	11
Optional Controls .....	12
Operation .....	13
Wiring Diagrams .....	14
Interlocking HRV to Furnace .....	15
Air Flow Balancing .....	17-18
Troubleshooting .....	19
Maintenance .....	20



### \* LEAVE FOR HOMEOWNER

NOTE: Due to ongoing research and product development, specifications, ratings and dimensions are subject to change without notice.

## THERMALLY CONDUCTIVE, PATENTED ALUMINUM CORE

The cross-flow heat recovery core transfers heat between the two air streams. It is easily removed for cleaning or service.

## MOTORS AND BLOWERS

Each air stream has one centrifugal blower driven by a common PSC motor.

## FILTERS

Washable air filters in exhaust and supply air streams.

## MOUNTING THE HRV

Four threaded inserts at corners of case designed to accept four PVC reinforced polyester straps that are supplied with the unit.

## DEFROST

Damper defrost system; defrosts automatically as the outdoor temperature falls.

## CASE

Twenty gauge prepainted galvanized steel (G60) for superior corrosion resistance. Insulated to prevent exterior condensation. Drain connections two - 1/2" (12mm) OD.

## WEIGHT

63 lbs. (28.7 kg)

## SHIPPING WEIGHT

67 lbs. (30.4 kg)

## CONTROLS

### HRV System Control

HRV defaults to LOW SPEED when plugged in. HIGH SPEED option is accessible by connecting remote controls to designated terminals inside electrical box of HRV.

Standard LOW SPEED SETTING can be increased by manipulating switches in electrical box. OFF(Standby)/LOW or OFF/HIGH speed operation also available by manipulating switches.

## OPTIONAL ACCESSORIES

**28 884 20 Minute Fan Timer** - (3 wire) 20 gauge wire (min.) 100' length (max.)

**22 026 Weather Hoods**, 2 - 6" (150mm) c/w 1/4" (6mm) screen

**28 883 Dehumidistat Ventilation Control** - Dehumidistat with ON/OFF

**28 882 Dehumidistat Control** - Dehumidistat

All units conform to CSA and UL standards.

## Performance (H.V.I. certified)

Net supply air flow in cfm (L/s) against external static pressure

<b>E.S.P</b> <i>(external static pressure)</i>	<b>LT15</b> <i>[cfm (L/s)]</i>
@ 0.1" (25 Pa)	177 (83)
@ 0.2" (50 Pa)	164 (77)
@ 0.3" (75 Pa)	156 (73)
@ 0.4" (100 Pa)	143 (67)
@ 0.5" (125 Pa)	123 (58)
Max.Sensible Effectiveness -13°F (-25°C) outdoor air 72°F (22°C) 40% RH indoor air	78%
Test Parameters	67cfm (32L/s)
Sensible Effectiveness 32°F (0°C)	76%
*Sensible Efficiency 32°F (0°C)	66%
*Sensible Efficiency -13°F (-25°C)	60%
**Latent Efficiency 95°F (35°C)	0%
Total Efficiency 95°F (35°C)	20%
VAC @ 60HZ	120
WATTS / High @ .3" W.C.	173
WATTS / Low @ .3" W.C.	63

\*Sensible Efficiency - thermal \*\*Latent Efficiency - moisture  
Note: Effectiveness - based on temp. differential between the 2 airstreams  
Efficiency - includes parasitic losses from fan and defrosting

## Dimensions HRV inches (mm)

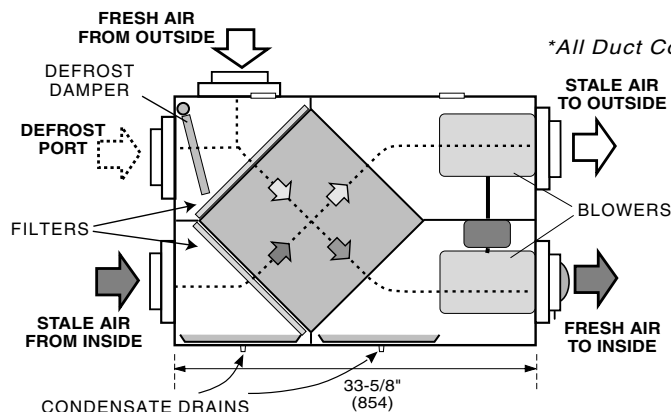

\*All Duct Connections 6" (150mm)

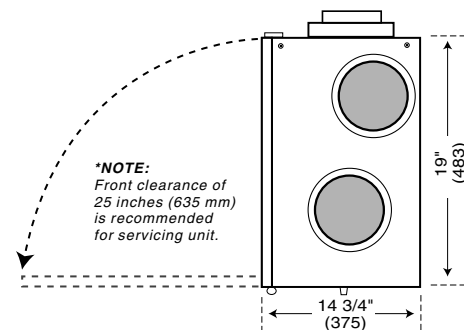

\*NOTE:  
Front clearance of  
25 inches (635 mm)  
is recommended  
for servicing unit.

DATE: \_\_\_\_\_

PROJECT: \_\_\_\_\_

MECHANICAL CONTRACTOR: \_\_\_\_\_



**THERMALLY CONDUCTIVE, PATENTED ALUMINUM CORE**

The cross-flow heat recovery core transfers heat between the two air streams. It is easily removed for cleaning or service.

**MOTORS AND BLOWERS**

Each air stream has one centrifugal blower driven by a common PSC motor.

**FILTERS**

Washable air filters in exhaust and supply air streams.

**MOUNTING THE HRV**

Four threaded inserts at corners of case designed to accept four PVC reinforced polyester straps that are supplied with the unit.

**DEFROST**

Damper defrost system; defrosts automatically as the outdoor temperature falls.

**CASE**

Twenty gauge prepainted galvanized steel (G60) for superior corrosion resistance. Insulated to prevent exterior condensation. Drain connections two - 1/2" (12mm) OD.

**WEIGHT**

63 lbs. (28.7 kg)

**SHIPPING WEIGHT**

67 lbs. (30.4 kg)

**CONTROLS**

**HRV System Control**

HRV defaults to LOW SPEED when plugged in. HIGH SPEED option is accessible by connecting remote controls to designated terminals inside electrical box of HRV.

Standard LOW SPEED SETTING can be increased by manipulating switches in electrical box. OFF(Standby)/LOW or OFF/HIGH speed operation also available by manipulating switches.

**OPTIONAL ACCESSORIES**

- 28 884 20 Minute Fan Timer - (3 wire) 20 gauge wire (min.) 100' length (max.)
- 22 026 Weather Hoods, 2 - 6" (150mm) c/w 1/4" (6mm) screen
- 28 883 Dehumidistat Ventilation Control - Dehumidistat with ON/OFF
- 28 882 Dehumidistat Control - Dehumidistat

All units conform to CSA and UL standards.

<b>Performance (H.V.I. certified)</b>	
<i>Net supply air flow in cfm (L/s) against external static pressure</i>	
<b>E.S.P</b>	<b>LT20</b>
<b>(external static pressure)</b>	<b>[cfm (L/s)]</b>
@ 0.1" (25 Pa)	214 (101)
@ 0.2" (50 Pa)	206 (97)
@ 0.3" (75 Pa)	193 (91)
@ 0.4" (100 Pa)	184 (87)
@ 0.5" (125 Pa)	170 (80)
Max.Sensible Effectiveness -13°F (-25°C) outdoor air 72°F (22°C) 40% RH indoor air	69%
Test Parameters	127cfm (60L/s)
Sensible Effectiveness 32°F (0°C)	67%
*Sensible Efficiency 32°F (0°C)	60%
*Sensible Efficiency -13°F (-25°C)	59%
**Latent Efficiency 95°F (35°C)	0%
Total Efficiency 95°F (35°C)	20%
VAC @ 60HZ	120
WATTS / High @ .3" W.C.	182
WATTS / Low @ .3" W.C.	70

*\*Sensible Efficiency - thermal \*\*Latent Efficiency - moisture  
Note: Effectiveness - based on temp. differential between the 2 airstreams  
Efficiency - includes parasitic losses from fan and defrosting*

**Dimensions HRV inches (mm)**

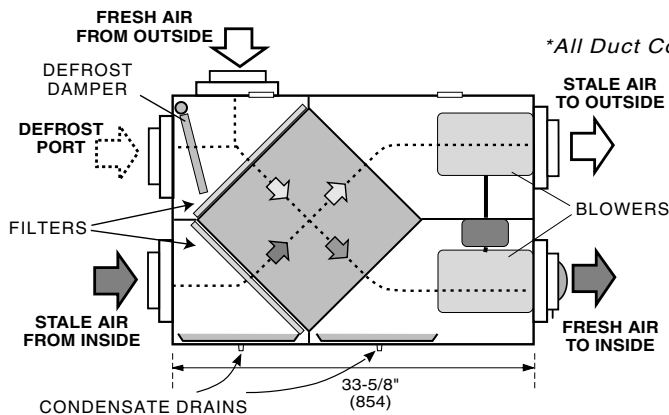

\*All Duct Connections 6" (150mm)

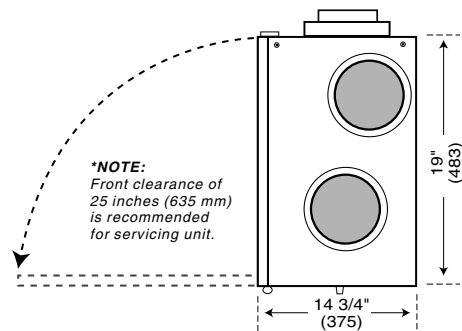

**\*NOTE:**  
Front clearance of 25 inches (635 mm) is recommended for servicing unit.

DATE: \_\_\_\_\_

PROJECT: \_\_\_\_\_

MECHANICAL CONTRACTOR: \_\_\_\_\_



## Clearances and Requirements

### **⚠ WARNING**

Before installation, careful consideration must be given to how this system will operate if connected to any other piece of mechanical equipment, i.e. a forced air furnace or air handler, operating at a higher static. After installation, the compatibility of the two pieces of equipment must be confirmed, by measuring the air flows of the ventilator, by using the balancing procedure found in this manual.

It is always important to assess how the operation of any HRV may interact with vented combustion equipment (i.e. Gas Furnaces, Oil Furnaces, Wood Stoves, etc.)

**NEVER** install a ventilator in a situation where its normal operation, lack of operation or partial failure may result in the backdrafting or improper functioning of vented combustion equipment!!!

### Connecting Appliances to the HRV

The following appliances should not be connected to the HRV:

- clothes dryer
- range top
- stovetop fan
- central vacuum system

### **⚠ CAUTION**

**Lint, dust or grease will collect in the HRV damaging the unit.**

**NOTE:** Connecting any of these to the HRV will invalidate your warranty.

## Installation

### **⚠ WARNING**

Improper installation, adjustment, alteration, service or maintenance can cause property damage, personal injury or loss of life. Installation and service must be performed by a qualified installer or service agency.

### **⚠ WARNING**



**Electric shock hazard. Can cause injury or death. Before attempting to perform any service or maintenance, turn the electrical power to unit OFF at disconnect switch(es). Unit may have multiple power supplies.**

#### Location Selection

The HRV must be located in a heated space where it will be possible to conveniently service the unit. Typically the HRV would be located in the mechanical room or an area close to the outside wall where the weather hoods will be mounted. If a basement area is not convenient or does not exist, a utility or laundry room may be used.

Attic installations are not normally recommended due to:

- A) the complexity of work to install
- B) freezing conditions in the attic
- C) difficulty of access for service and cleaning

The HRV unit must be installed in a horizontal position as shown in the illustration below. The unit should be suspended using the provided hanging straps. If necessary, the unit may be installed on a platform: however, the cabinet should be isolated from the platform to prevent vibration transmission. The unit must be level. Sufficient clearance at the front of the access door is required for servicing the air filters and core. A minimum of 25" (635mm) clearance is recommended so the door can be opened. Four PVC reinforced polyester hanging straps are provided for hanging the HRV from the basement floor joists.

#### Suspending the Unit

The hanging straps should be attached to the unit at the top end corners (mounting screws are already located on the HRV case). Securely fasten the other end of the straps to the floor joists with wide head nails (not supplied), making sure the UNIT IS LEVEL. The straps are designed to reduce the possibility of noise, resonance or harmonics; therefore using the full length of the strap between the HRV and the floor joists is recommended.

#### Weather Hood Location and Installation

Weatherhood kit includes two fixed-cover hoods with a 1/4" (6mm) mesh screen.

#### Exhaust Weather Hood Requirements

- At least 6' (2 m) from the ventilation air intake\*
- At least 18" (457mm) above ground or above the depth of expected snow accumulation\*

## ⚠ CAUTION

Unit must be installed level to ensure proper condensate drainage. Due to the broad range of installation and operational conditions, consideration must be given for the possibility of condensation forming on the unit or connecting ducting. Objects below the installation may be exposed to condensate.

- At least 3' (1 m) away from the corner of the building\*
- At least 3' away from gas meter, electric meter or a walkway where fog or ice could create a hazard\*
- Not into a garage, workshop or other unheated space

When installing the weather hood, its outside perimeter must be sealed with exterior caulking.

\* Local code may require greater distances.

### Intake Weather Hood Requirements

- Should be located upstream (if there are prevailing winds) from the exhaust outlet
- At least 6' (2 m) from the exhaust weather hood \*
- At least 6' (2 m) away from dryer vents and air handler exhaust (medium or high efficiency furnaces)\*
- A minimum of at least 6' (2 m) from driveways, oil fill pipes, gas meters, or garbage containers, swimming pools\*
- At least 18" (457mm) above the ground, or above the depth of expected snow accumulation\*
- At least 3' (1 m) from the inside/outside corner of the building\*
- Do not locate in a garage, attic or crawl space

\* Local code may require greater distances.

### Weather Hood Clearances

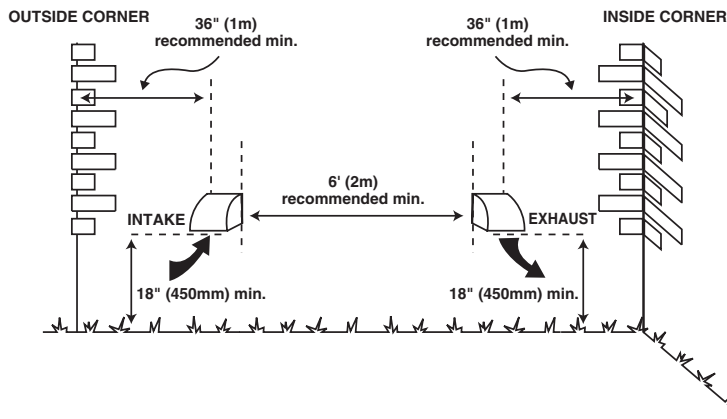

### Suspending the Unit using the Provided Hanging Straps

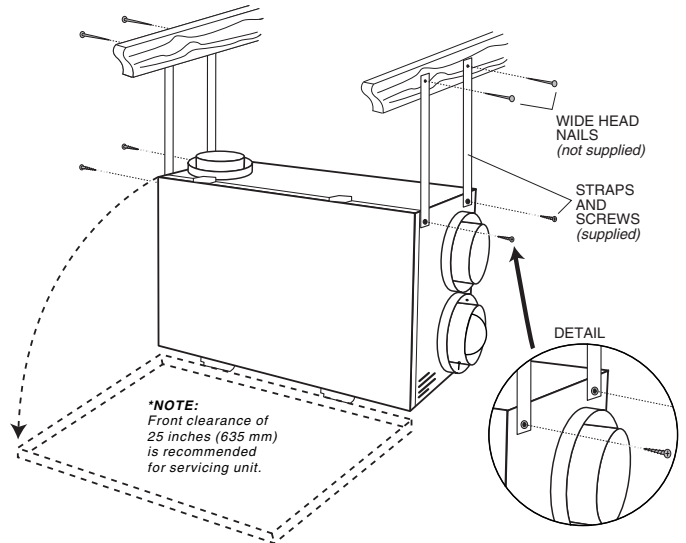

Unit is designed for horizontal installation only as shown.

Using full length hanger straps is recommended for vibration control, but can be shorter if required.

### Weatherhood Installation

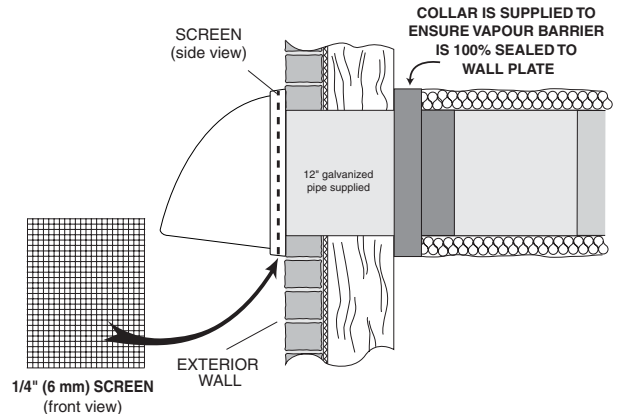

1. Thermal Collar slides over galvanized sleeve of Weatherhood.
2. Fasten Thermal Collar to Belt.
3. Slide the Insulated Flexible Ducting over the Weatherhood's galvanized sleeve and fasten it to the Thermal Collar.
4. Hood is hinged to allow for easy access for cleaning of bird screen.

## ⚠ CAUTION

Weather hood arrangement - requires a minimum of 6' (2m) separation and a minimum of 18" (460mm) clearance above grade or anticipated snow level.

### Air Duct Design and Installation

A well designed and installed ducting system will allow the HRV to operate at its maximum efficiency.

Always try to keep duct runs as short and straight as possible. See Installation Diagrams for various installation options.

The inner and outer liners of the flexible insulated duct must be clamped to the sleeve of the weather hoods (as close to the outside as possible) and the appropriate port on the HRV. It is very important that the fresh air intake line be given special attention to make sure it is well sealed. A good bead of high quality caulking (preferably silicone sealant) will seal the inner flexible duct to both the HRV port and the weather hood prior to clamping with a large zip tie.

To minimize air flow restriction, the flexible insulated duct that connects the two outside weather hoods to the HRV should be stretched tightly and be as short as possible.

Twisting or folding the duct will severely restrict air flow. See below for the recommended connection of flexible insulated ducts to the the outside weather hoods and the HRV.

#### Installing the Ducting Between the HRV & Living Areas in the House

To maximize airflow in the duct system, all ducts should be kept short and have as few bends or elbows as possible. Forty-five degree elbows are preferred to 90° elbows. Use "Y" tees instead of 90° elbows whenever possible.

All duct joints must be fastened with screws, rivets or duct sealant and wrapped with mastic or a quality duct tape to prevent leakage. Mastic is preferred but if duct tape is used, we recommend aluminum foil duct tape.

Galvanized ducting from the HRV to the living areas in the house is recommended whenever possible, although flexible duct can be used in moderation if necessary.

To avoid possible noise transfer through the duct system, a short length (approximately 12 inches or 300mm) of non-metallic flexible insulated duct should be connected between the HRV and the supply/exhaust duct system.

The main supply and return lines to/from the HRV must be 6 inches (150mm) minimum. Branch lines to the individual rooms may be as small as 4 inches (100mm), but 5 inch (125mm) lines are preferred .

All ducts running through attics and unheated spaces must be sealed and insulated to code.

#### Fresh Air Ducting

In applications that do not include an air handler, fresh air should be supplied to all bedrooms and living areas, excluding bathrooms, kitchen and utility areas. Grilles should be located high on a wall or in ceiling locations.

## ! WARNING

**Include a short length of fabric flex duct or other non-metallic connector in this hard ducted line in order to keep the HRV separately grounded (electrically) from the air handler. This will avoid a possible shock hazard to service people if a short to ground develops in one of the devices.**

Grilles that diffuse the air comfortably such as the Round Diffuser are recommended.

If the floor is the only option available, then special care should be taken in locating grilles. Areas such as under baseboard heaters will help to temper the air. Also optional inline duct heaters are available for mounting in the supply duct work to add heat if required.

#### Direct Connection to Air Handler Duct System

Should you wish to hard duct the fresh air from the HRV directly into the cold air return of the air handler, remember to check the air flow balance of the HRV with the air handler fan both "ON" and "OFF" to determine that it does not imbalance the unit more than 10%.

#### Indirect Connection to Air Handler Duct System

If permitted by local codes, an indirect connection may be made between the HRV fresh air duct and the air handler return plenum. The fresh air from the unit may be directed at a grille installed in the cold air return duct of the air handler. The fresh air outlet from the HRV should be no closer than 4 inches (100mm) and no more than 12 inches (300mm) from the grille.

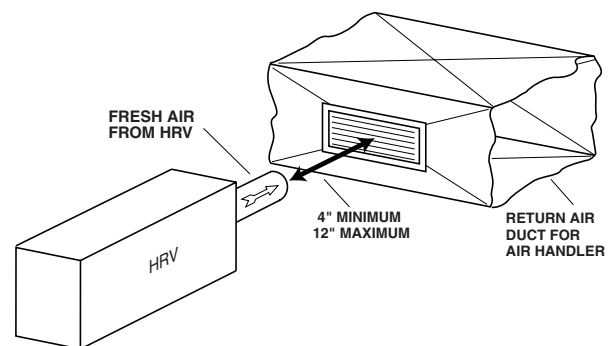

### Stale Air Exhaust System

The stale air exhaust system draws air from the points in the house where the worst air quality problems occur. Stale air ducts should be installed in the bathroom, kitchen, and laundry room. Applications such as greenhouses, atriums, swimming pools, saunas, etc. have unique ventilation requirements which should be addressed with an isolated ventilation system. Also, the air handler return duct may be used to exhaust from. In this method, the exhaust air is not ducted back to the HRV with "dedicated lines" from bathrooms, kitchens, etc. Instead, the exhaust air is drawn out of the cold air return of the air handler. **The air handler blower must be running when the unit is operating for this system to be effective.**

**⚠ CAUTION**

**Do not mount exhaust grille within 4' (1.2m) (horizontally) from stove to prevent grease from entering HRV.**

### Balancing Dampers and Grilles

Balancing dampers and/or adjustable grilles should be used to balance the flow rates into and out of various rooms.

Grilles or diffusers should be positioned high on the wall or in the ceiling. Kitchen exhaust grilles must never be connected to a range hood. They should be installed at least 4 feet (1.2m) horizontally away from the stove. A hinged 6"X10" (150 X 250mm) rectangular kitchen exhaust grille is available as part number. This grille includes a removable grease filter. Canadian building codes require that kitchen grilles be equipped with washable filters.

Field-supplied balancing dampers should be installed external to the unit to balance the amount of stale air being exhausted with the amount of fresh air being brought into the house. Refer to Air flow Balancing section.

### Kitchen Grille

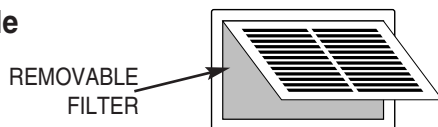

### The Round Diffuser is available in

- 4" (100mm)
- 6" (150mm)
- 8" (200mm)

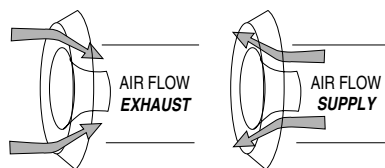

### Round Diffusers

### Drain Connection (HRV Only)

During a defrost cycle, the HRV may produce some condensation. This water should flow into a nearby drain, or be taken away by a condensate pump.

**⚠ CAUTION**

**The HRV and all condensate lines must be installed in a space where the temperature is maintained above the freezing point.**

The HRV cabinet has prepunched holes for the drain (see below). Insert the drain spout through the hole in the drain pan. Do not forget the "O ring" which seals each spout to the pan. **REMEMBER TO HAND TIGHTEN ONLY** the washer and lock nut which hold the drain spout in place.

Construct a P-Trap using the plastic tee connector. Cut two lengths of hose and connect each piece to an end of the "T" fitting, then connect the other ends to the two drain spouts. Position the "T" fitting to point upward, and connect the drain line. Tape or fasten base to avoid any kinks. This creates a "trap" which will hold some condensate and prevent odors from being drawn up the hose and into the fresh air supply of the HRV.

### "P" Trap (HRV only)

#### DRAIN HOSE PLUMBING

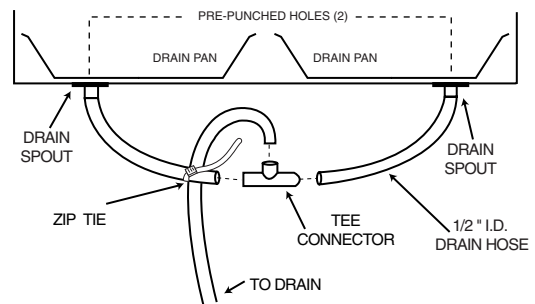

#### HARD PIPE PLUMBING

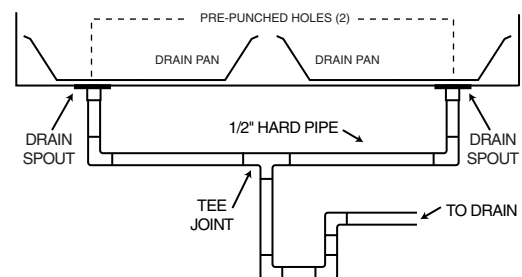

**Note: Secondary drain pan may be required to protect from condensate leakage.**

**Partially Dedicated System for HRV**

- Stale air drawn from key areas of home (bathroom, kitchen, laundry)
- Fresh air supplied to return air duct of air handler

**⚠ WARNING**  
**HRV must be balanced.**

**DIRECT CONNECTION of the SUPPLY AIR STREAM to the AIR HANDLER COLD AIR RETURN (Stale air drawn from key areas of home)**

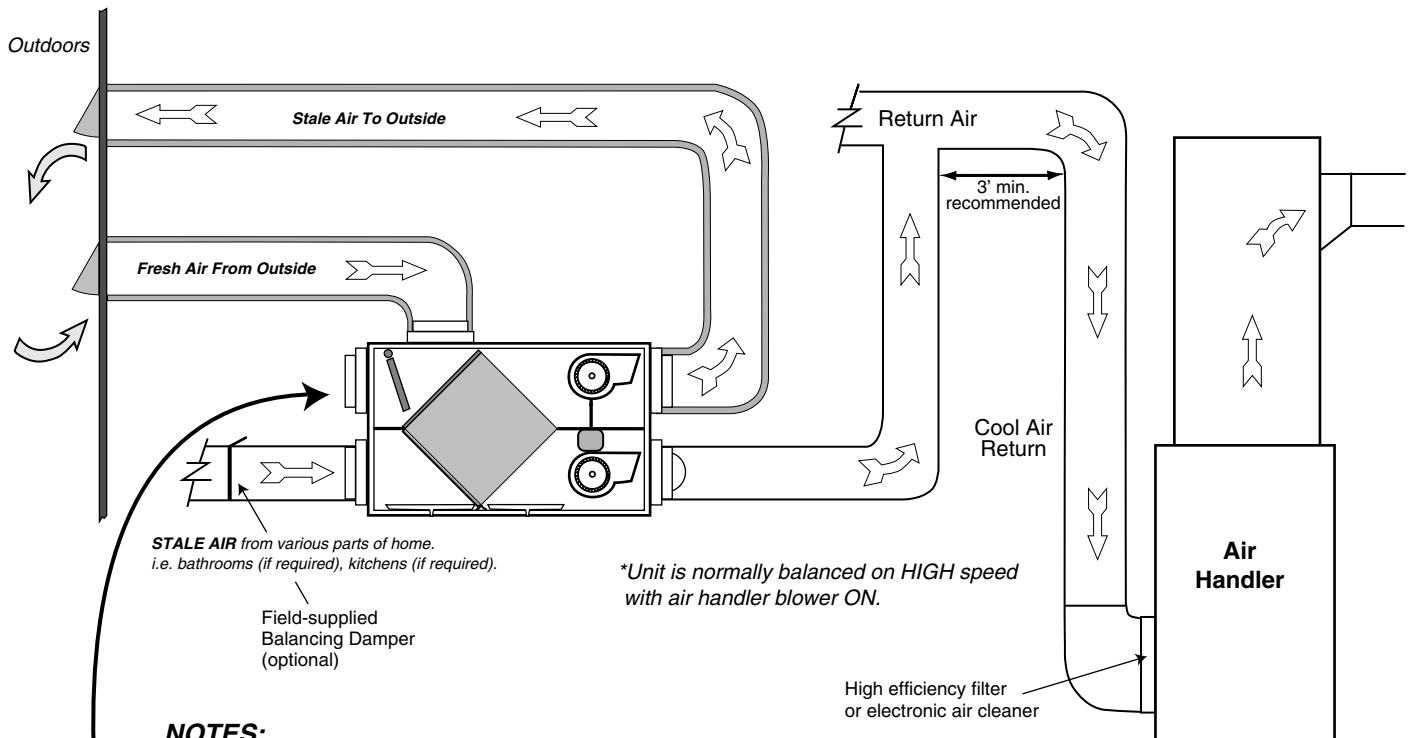

**NOTES:**

1. Air handler blower may be required to operate when HRV is on to provide good air distribution.
2. Weather hood arrangement is for drawing purposes only. 6' (2m) minimum separation required. 18" (460mm) above grade minimum or above anticipated snow level.
3. Due to the differences in pressure between the HRV and the equipment it is being connected to, the HRV air flow must be confirmed on site, using the balancing procedure found in the installation manual.

**⚠ WARNING**  
 Defrost air port needs to be drawn from clean area without combustion appliances. To avoid backdrafting of combustion products, never draw defrost air from a room with a naturally aspirated appliance, i.e. furnace, hot water heater, gas dryer, stove, fire place etc.

**⚠ CAUTION**  
 Weather hood arrangement - requires a minimum of 6' (2m) separation and a minimum of 18" (460mm) clearance above grade or anticipated snow level.



## Simplified Installation for HRV

(Return/Return Method)

- It is mandatory that the air handler blower run continuously or HRV operation be interlocked with the air handler blower.
- Check local codes/authority having jurisdiction for acceptance.

### **⚠ WARNING**

**HRV must be balanced.**

### **DIRECT CONNECTION of both the HRV SUPPLY AIR STREAM and EXHAUST AIR STREAM to the AIR HANDLER COLD AIR RETURN**

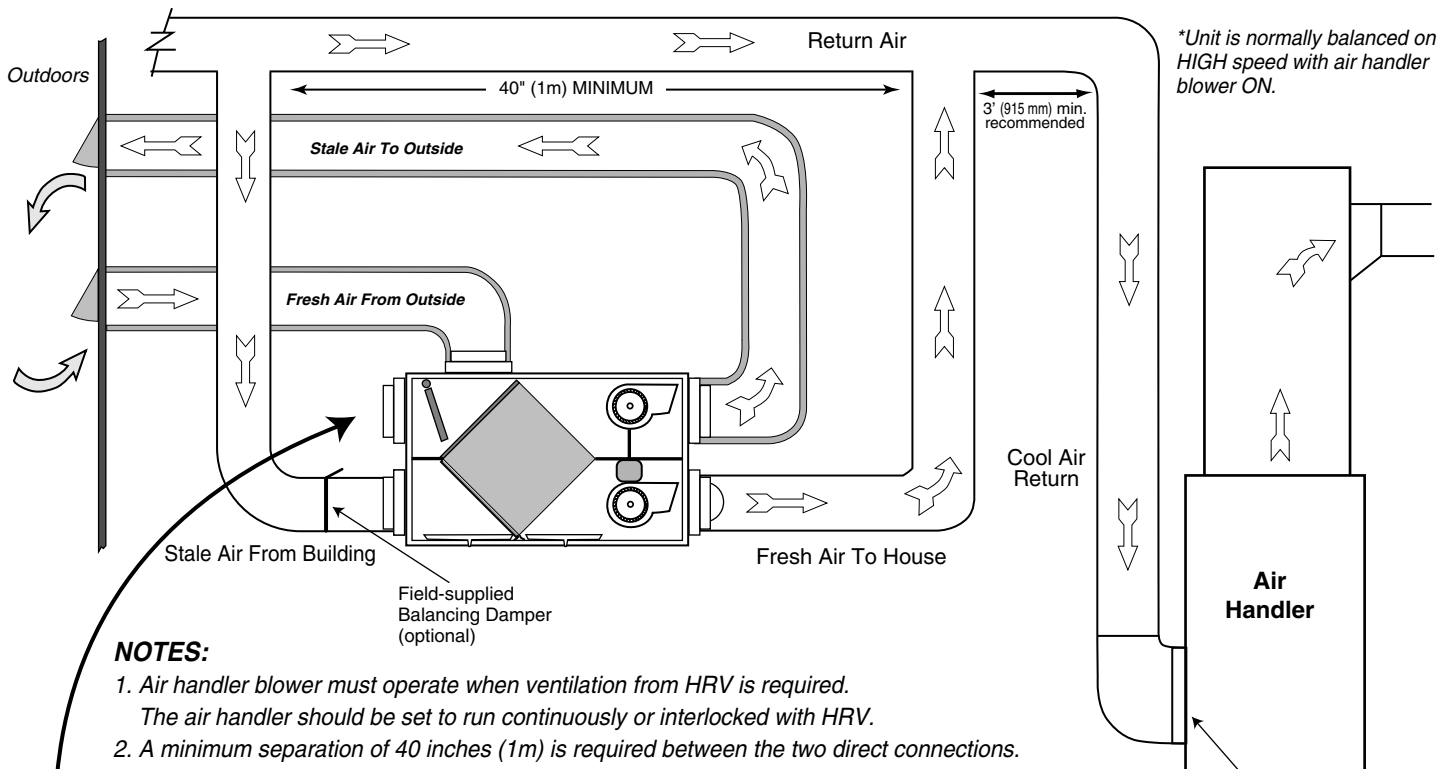

*\*Unit is normally balanced on HIGH speed with air handler blower ON.*

#### **NOTES:**

1. Air handler blower must operate when ventilation from HRV is required.  
The air handler should be set to run continuously or interlocked with HRV.
2. A minimum separation of 40 inches (1m) is required between the two direct connections.
3. The exhaust air connection should be upstream of the supply air connection to prevent exhausting any fresh air.
4. Weather hood arrangement is for drawing purposes only. Six feet (2m) minimum separation required.  
18" inches (460mm) above grade minimum or above anticipated snow level.
5. Due to the differences in pressure between the HRV and the equipment it is being connected to, the HRV's air flow must be confirmed on site, using the balancing procedure found in the installation manual.

### **⚠ WARNING**

**Defrost air port needs to be drawn from clean area without combustion appliances. To avoid backdrafting of combustion products, never draw defrost air from a room with a naturally aspirated appliance, i.e. furnace, hot water heater, gas dryer, stove, fire place etc.**

### **⚠ CAUTION**

**Weather hood arrangement - requires a minimum of 6' (2m) separation and a minimum of 18" (460mm) clearance above grade or anticipated snow level.**

## Fully Dedicated System for HRV

- Stale air drawn from key areas of home (bathroom, kitchen, laundry)
- Fresh air supplied to main living areas of house

**⚠ WARNING**

**HRV must be balanced.**

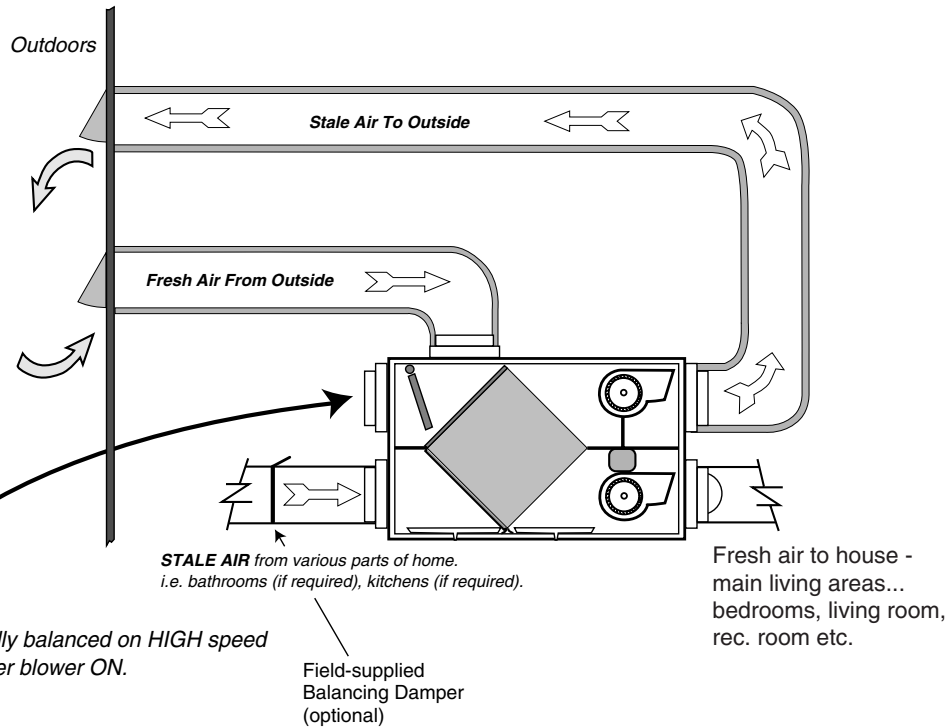

### NOTES:

1. Weather hood arrangement is for drawing purposes only. 6' (2m) minimum separation required. 18" (460mm) above grade minimum or above anticipated snow level.
2. The HRV air flow must be confirmed on site, using the balancing procedure found in the installation manual.

**⚠ WARNING**

**Defrost air port needs to be drawn from clean area without combustion appliances. To avoid backdrafting of combustion products, never draw defrost air from a room with a naturally aspirated appliance, i.e. furnace, hot water heater, gas dryer, stove, fire place etc.**

**⚠ CAUTION**

**Weather hood arrangement - requires a minimum of 6' (2m) separation and a minimum of 18" (460mm) clearance above grade or anticipated snow level.**

## Electrical

The HRV unit should be plugged into a standard designated (120VAC) electrical outlet with a ground. The outlet should be serviced by a separate 15 amp/120V circuit. An extension cord should not be used with this appliance. A qualified service technician should make any required electrical connections.

### Remote Control Connections

Low voltage connections between the remote controls, the dehumidistat, or the fan timer should be made by a qualified service technician. Low voltage wires from the remote controls are connected to the HRV micro-processor board.

## WARNING

**In order to prevent electric shock when cleaning or servicing the HRV, it is extremely important to confirm the polarity of the power line that is switched by the safety (disconnect) switch. The hot line (black) is the proper line to be switched. To confirm the proper polarity, use a voltmeter or test lamp to ensure there is no power after the switch when the door is open. Check between that point and ground (on the cabinet). Always make sure that the HRV is properly grounded.**

## Optional Remote Control Devices Low Voltage

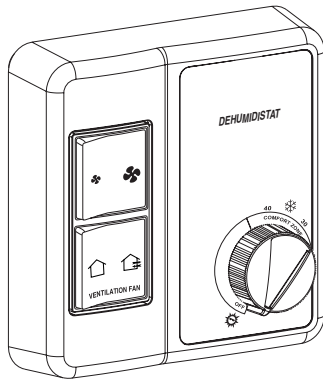

### DEHUMIDISTAT VENTILATION CONTROL (D.V.C.)

\* *remove jumper on circuit board  
when using this control*

\*\* *requires 3 wires*

- Designed for a central location
- Ventilation control turns HRV system ON and OFF
- Dehumidistat increases ventilation when required
- High speed override switch
- Great for building code requirements
- Low voltage
- Connect one per HRV only
- Connects to red, black and orange

**Part No. 28 883**



### REMOTE DEHUMIDISTAT

\**requires 2 wires*

- anywhere humidity is a concern
- provides high speed ventilation when ..humidity level exceeds selected setting
- Connects to red and black

**Part No. 28 882 White**

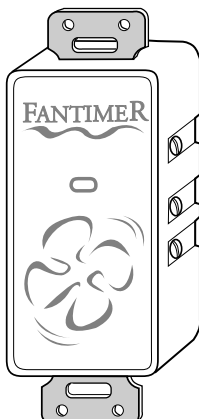

### 20 MINUTE TIMER

\**requires 3 wires*

- provides high speed for 20 minutes
- maximum wire length 100'
- connect up to 4
- connects to red, black and green terminals

**Part No. 28 884**

## Operation

### Self Test

The ventilator will automatically initiate a self test sequence when power is applied. Fan motor is cycled and then damper motor is cycled. Duration: Approximately 1.5 mins.

### Changing Speeds

The ventilator automatically operates on its lowest speed when plugged in or switched on. This setting is factory supplied from an autotransformer with two selectable low speeds. To switch to a continuous medium low speed, an installing contractor must interchange the red and blue wires from the autotransformer inside the electrical box. Whether or not this change is made, the HRV will only be able to access a single selected low speed.

High speed is available with the use of optional remote controls connected to the appropriate terminals inside the electrical box.

### How much ventilation do I need?

During seasons when your windows and doors are closed (winter and summer if air conditioned) the HRV should operate continuously when the dwelling is occupied, and either continuously or intermittently when not occupied.

For most installations the HRV will normally be set to operate continuously on low speed. To suit various lifestyles, the HRV offers a selection of operating modes (See "Operation Mode Selection" on this page).

### Method of Operation

- Good** - intermittent operation at all times
- Better** - continuous operation during day or occupied conditions, intermittent at night or unoccupied
- Best** - recommended continuous operation of both HRV and furnace/air handler blower

### Operation Mode Selection

Various combinations of operating modes are listed below should you wish to change the factory settings.

See Optional Controls for controlling options and descriptions.

### Installer selectable DIP Switches

REMOTE	OFF	OFF= Standby. When unit is switched off by a remote switch, all override devices activate high speed
JSHS	OFF	

REMOTE	ON	Low speed ON and all devices activate high speed <b>Factory default setting</b>
JSHS	OFF	

REMOTE	OFF	No low speed, high speed always on
JSHS	ON	

REMOTE	ON	No Low speed, all devices activate high speed Standby setting
JSHS	ON	

# LT15 & LT20 WIRING DIAGRAM

**LEGEND**

HIGH VOLTAGE	
12V LOW VOLTAGE	
FIELD INSTALLED	
12V LOW VOLTAGE	

## FAN MOTOR DETAILS

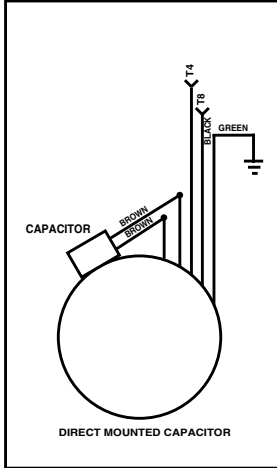

## DEFROST DETAILS

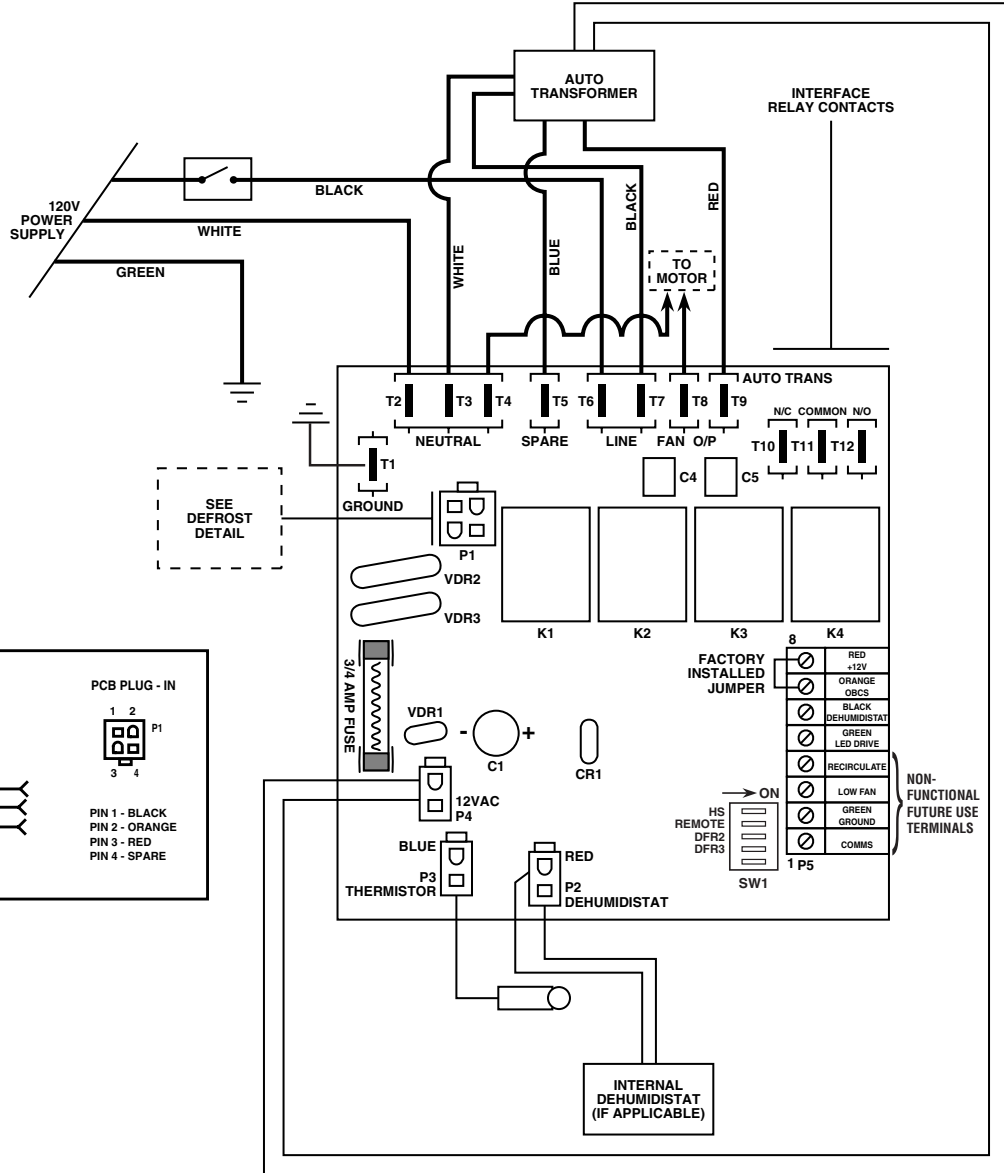
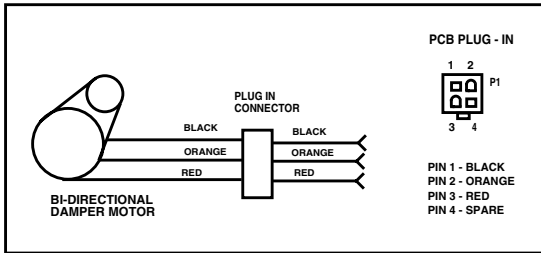

## WALL MOUNTED DEHUMIDISTAT

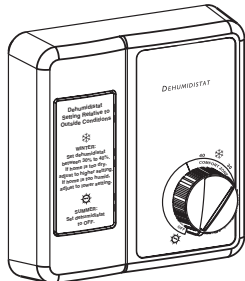

- Red to Red (12V)
- Black to Black (Dehumidistat)

## 20 MINUTE FAN TIMER



- Black to Black (Dehumidistat)
- Red to Red (12V)
- Green to Green (LED Drive)

## DVC

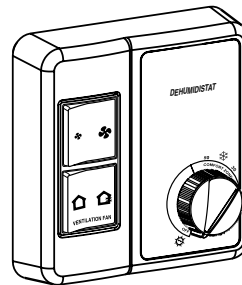

- \*Remove factory installed jumper on circuit board
- Red to Red (12V)
- Black to Black (Dehumidistat)
- Orange to Orange (OBCS)

# Interlocking HRV Operation to an Airhandler/Furnace Blower

When using the Interface relay contacts to initiate blower operation on a furnace, certain thermostats will initiate the outdoor cooling condenser when R and G are closed.

Use this wiring configuration to prevent the Interface relay contacts from initializing the condenser unit. This problem can occur at the thermostat because the **Y** terminal is connected to the **G** terminal internal to the stat. When **R** and **G** are closed at the furnace (by dehumidistat or relay) 24 Volts is sent to **G** at thermostat. 24 Volts is then sent through **Y** which will initiate outdoor condenser.

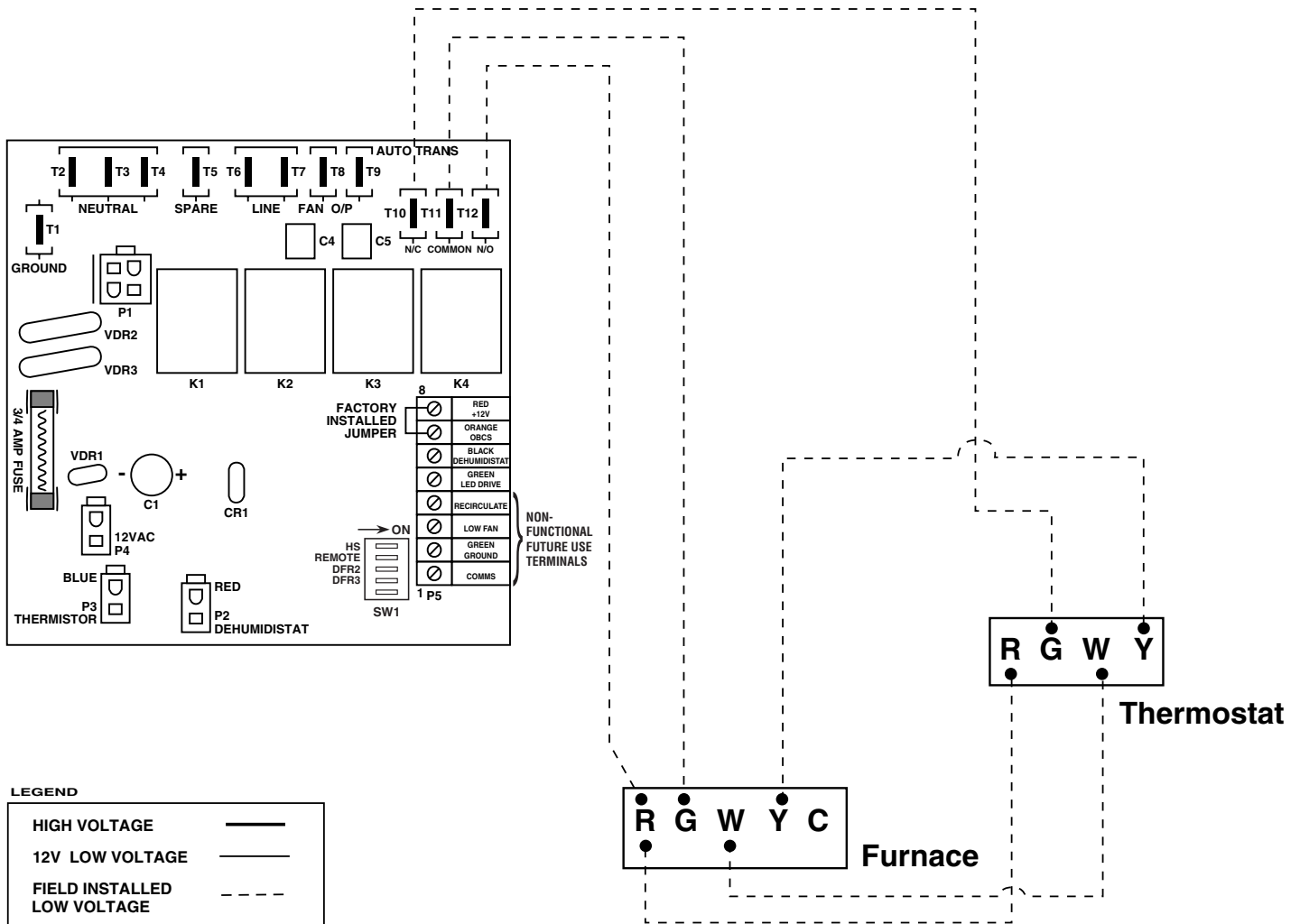

### Automatic Damper Defrost (HRV only)

HRV models have an electronically controlled damper defrost mechanism. If the outside temperature drops below -4°C (25°F), the defrost timer is activated. As a self-test, the HRV will run a 3 minute defrost approx. 4 seconds after the thermistor (temperature sensor) is removed from the circuit board. In normal operation, when temperatures drop below -4°C (25°F) the timer will wait approximately 17 minutes (during which time the core may experience some nominal frost buildup), and then activate the motor-driven damper door mechanism, which opens the defrost port while at the same time closing off the supply air from outside. After approximately 3 minutes, the damper operates in the opposite direction to close off the defrost port and reopen the fresh air supply port. The 3 minute defrost cycle and 17 minute wait time repeat until the temperature again rises above -4°C (25°F). During defrost, the HRV will automatically switch to high speed in order to defrost the core.

*\*Note: The 3 minute defrost and 17 minute wait time are factory set. Should you wish to lengthen the wait time between defrosts, refer to chart below.*

DFR2	DFR3	Defrost Time	Wait Time
ON	OFF	3 min.*	17 min.*
ON	ON	3 min.	25 min.
OFF	ON	3 min.	30 min.
OFF	OFF	3 min	17 min.

*Note: All times in defrost are 3 minutes. The defrost will not activate unless the fans are working.*

### Dehumidistat Operation (HRV only)

The optional HRV remote controls include a dehumidistat which controls humidity levels during the heating season. The control has a selector knob with setpoints ranging from 20% to 80% relative humidity (RH). Most people are comfortable when indoor relative humidity levels are in a range from 30 to 45%.

The dehumidistat switches the ventilator to high speed when the moisture level in the home exceeds the desired setpoint. The dehumidistat switches the HRV back to low speed ventilation when humidity has been reduced below the set point. **The dehumidistat should only be used during the heating season.** It must be set to the OFF position throughout the rest of the year.



## Air Flow Balancing

It is necessary to have balanced air flow in an HRV. The volume of air brought in from the outside must equal the volume of air exhausted by the unit. If the air flow is not properly balanced, then:

- The HRV may not operate at its maximum efficiency
- A negative or positive air pressure may occur in the house
- The unit may not defrost properly
- Failure to balance HRV properly may void warranty

### CAUTION

**Ensure balanced air flow in HRV. Excessive positive pressure may drive moist indoor air into the external walls of the building where it may condense (in cold weather) and degrade structural components. May also cause key holes to freeze up.**

**Excessive negative pressure** may have several undesirable effects. In some geographic locations, soil gases such as methane and radon gas may be drawn into the home through basement/ground contact areas.

*Read the Application Warning in Clearances & Requirements section of this manual!*

### WARNING

**Ensure balanced air flow in HRV. Excessive negative pressure may also cause the back-drafting of vented combustion equipment.**

*tion of this manual!*

**Prior to balancing, ensure that:**

1. All sealing of the duct system has been completed.
2. All of the HRV's components are in place and functioning properly.
3. Balancing dampers are fully open.
4. Unit is on HIGH speed.
5. Air flow in branch lines to specific areas of the house should be adjusted first prior to balancing the unit. A smoke pencil used at the grilles is a good indicator of each branch line's relative air flow.
6. After taking readings of both the stale air to the HRV duct and fresh air to the house duct, the duct with the lower CFM ([L/s] velocity) reading should be left alone, while the duct with the higher reading should be dampered back to match the lower reading.
7. Return unit to appropriate fan speed for normal operation
8. A field-supplied balancing damper for the stale air side is required for system balancing.

#### Balancing Procedure

The following is a method of field balancing an HRV using a Pitot tube, which is advantageous in situations when flow stations are not installed in the duct system. Procedure should

be performed with the HRV on high speed.

The first step is to operate all mechanical systems on high speed, which have an influence on the ventilation system, i.e. the HRV itself and the air handler, if applicable. This will provide the maximum pressure that the HRV will need to overcome, and allow for a more accurate balance of the unit.

Drill a small hole in the duct (about 3/16"), three feet downstream of any elbows or bends, and one foot upstream of any elbows or bends. These are recommended distances but the actual installation may limit the amount of straight duct.

The Pitot tube should be connected to a magnehelic gauge or digital manometer capable of reading from 0 to 0.25 in. (0-62 Pa) of water, preferably to 3 digits of resolution. The tube coming out of the end of the Pitot is connected to the high pressure side of the gauge. The tube coming out of the branch of the Pitot is connected to the low pressure or reference side of the gauge.

Insert the Pitot tube into the duct; pointing the tip into the air flow.

For general balancing it is sufficient to move the Pitot tube around in the duct and take an average or typical reading. Repeat this procedure in the other (supply or return) duct. Determine which duct has the highest air flow (highest reading on the gauge). Then damper that air flow back to match the lower reading from the other duct. The flow should now be balanced.

Actual air flow can be determined from the gauge reading. The value read on the gauge is called the velocity pressure. The Pitot tube comes with a chart that will give the air flow velocity based on the velocity pressure indicated by the gauge. This velocity will be in either feet per minute or meters per second. To determine the actual air flow, the velocity is multiplied by the cross sectional area of the duct being measured.

This is an example for determining the air flow in a 6" duct.

The Pitot tube reading was 0.025 inches of water.

From the chart, this is 640 feet per minute.

The 6" duct has a cross sectional area of  
$$= [3.14 \times (6" \div 12)^2] \div 4$$
$$= 0.2 \text{ square feet}$$

The air flow is then:

640 ft./min. x 0.2 square feet = 128 cfm

For your convenience, the cross sectional area of some common round duct is listed below:

DUCT DIAM. (inches)	CROSS SECTION AREA (sq. ft.)
5	0.14
6	0.20
7	0.27

The accuracy of the air flow reading will be affected by how close to any elbows or bends the readings are taken. Accuracy can be increased by taking an average of multiple readings as outlined in the literature supplied with the Pitot tube.

## Pitot Tube and Gauge

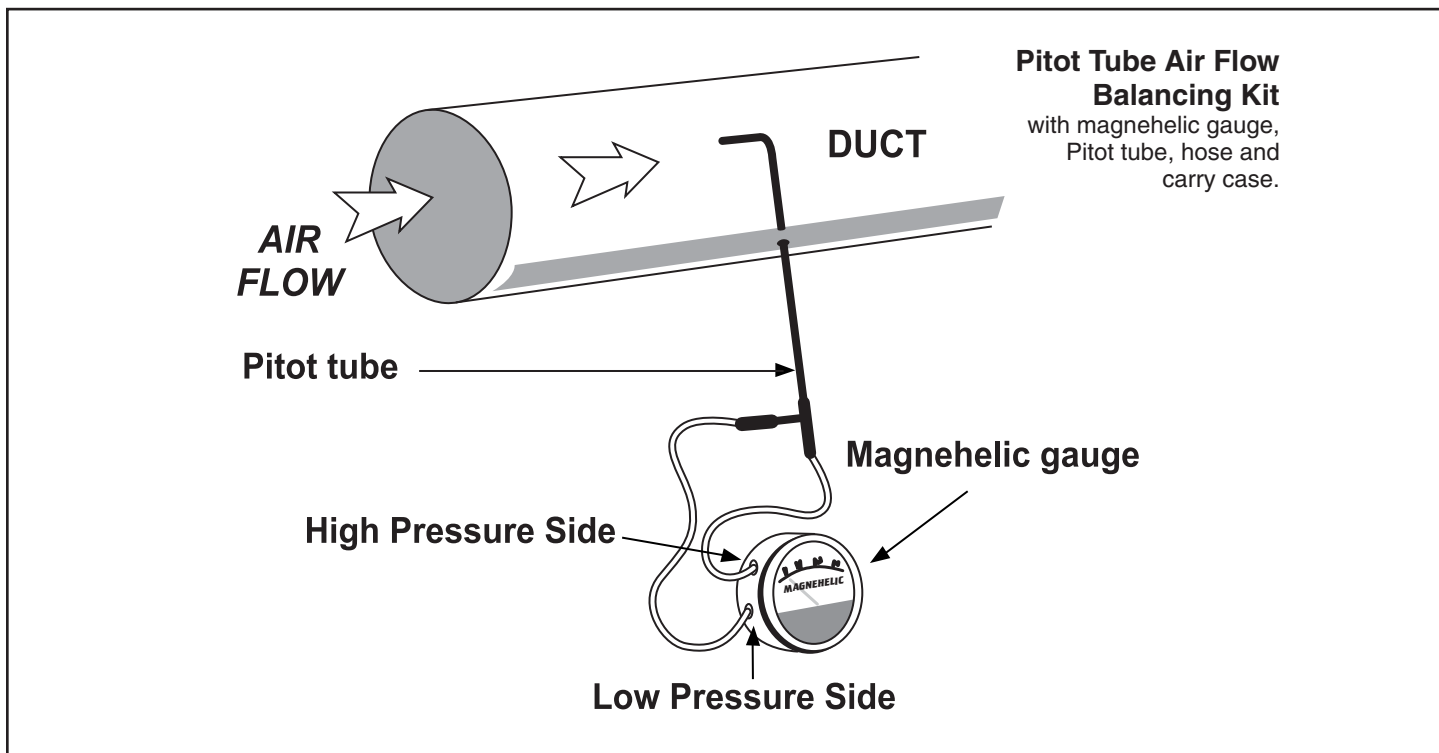

## Placement of Pitot Tube HRV

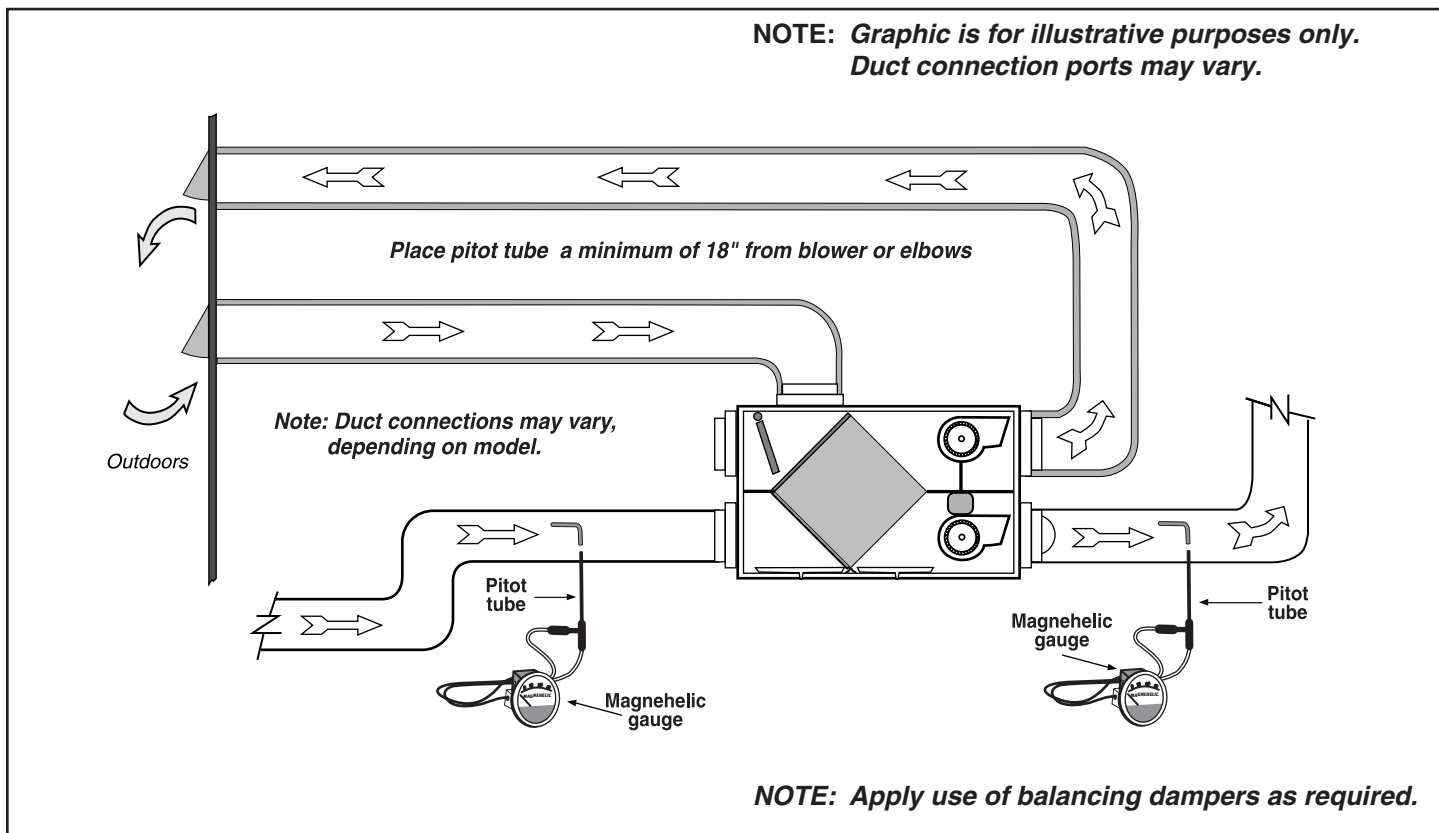

## Troubleshooting

Symptom	Cause	Solution
Poor Air Flow	<ul style="list-style-type: none"> <li>• 1/4" (6mm) mesh on the outside hoods is plugged</li> <li>• filters plugged</li> <li>• core obstructed</li> <li>• house grilles closed or blocked</li> <li>• dampers are closed if installed</li> <li>• poor power supply at site</li> <li>• duct is restricting HRV</li> <li>• improper speed control setting</li> <li>• HRV air flow improperly balanced</li> </ul>	<ul style="list-style-type: none"> <li>• clean exterior hoods or vents</li> <li>• remove and clean filter</li> <li>• remove and clean core</li> <li>• check and open grilles</li> <li>• open and adjust dampers</li> <li>• have electrician check supply voltage at house</li> <li>• check duct installation</li> <li>• increase the speed of the HRV</li> <li>• have contractor balance HRV</li> </ul>
Supply air feels cold	<ul style="list-style-type: none"> <li>• poor location of supply grilles, the air flow may irritate the occupant</li> <li>• outdoor temperature extremely cold</li> </ul>	<ul style="list-style-type: none"> <li>• locate the grilles high on the walls or under the baseboards, install ceiling mounted diffuser or grilles so as not to directly spill the supply air on the occupant (eg. over a sofa)</li> <li>• turn down the HRV supply speed. A small duct heater (1kw) could be used to temper the supply air</li> <li>• placement of furniture or closed doors is restricting the movement of air in the home</li> <li>• if supply air is ducted into air handler return, the air handler fan may need to run continuously to distribute ventilation air comfortably</li> </ul>
Dehumidistat is not Operating	<ul style="list-style-type: none"> <li>• improper connection to ventilator</li> <li>• external low voltage is shortened out by a staple or nail</li> <li>• check dehumidistat setting it may be on OFF</li> </ul>	<ul style="list-style-type: none"> <li>• check that the correct terminals have been used</li> <li>• check external wiring for a short</li> <li>• set the dehumidistat at the desired setting</li> </ul>
Humidity Levels are too High in Winter Condensation is appearing on the windows	<ul style="list-style-type: none"> <li>• dehumidistat is set too high</li> <li>• lifestyle of the occupants</li> <li>• moisture coming into the home from an unvented or unheated crawl space</li> <li>• moisture is remaining in the washroom/bathroom and kitchen areas</li> <li>• condensation seems to form in the spring and fall</li> <li>• HRV is set at too low a speed</li> </ul>	<ul style="list-style-type: none"> <li>• set dehumidistat lower</li> <li>• avoid hanging clothes to dry, storing wood and venting clothes dryer inside. Heating wood may have to be moved outside</li> <li>• vent crawl space and place a vapor barrier on the floor of the crawl space</li> <li>• ducts from the washroom/bathroom should be sized to remove moist air as effectively as possible, use of a washroom/bathroom fan for short periods will remove additional moisture</li> <li>• timer or fan can be added to washroom/bathroom exhaust</li> <li>• on humid days, as the seasons change, some condensation may appear but the home's air quality will remain high with some HRV use</li> <li>• increase speed of the HRV</li> </ul>
Humidity Levels are too Low	<ul style="list-style-type: none"> <li>• dehumidistat control set too low</li> <li>• blower speed of HRV is too high</li> <li>• lifestyle of occupants</li> <li>• HRV air flow may be improperly balanced</li> </ul>	<ul style="list-style-type: none"> <li>• set dehumidistat higher</li> <li>• decrease HRV blower speed</li> <li>• humidity may have to be added through the use of humidifiers</li> <li>• have a contractor balance HRV air flow</li> </ul>
HRV and / or Ducts Frosting up	<ul style="list-style-type: none"> <li>• HRV air flow is improperly balanced</li> <li>• malfunction of the HRV defrost system</li> </ul>	<ul style="list-style-type: none"> <li>• Note: minimal frost build-up is expected on cores before unit initiates defrost cycle functions</li> <li>• have HVAC contractor balance the HRV</li> <li>• ensure working properly.</li> </ul>
Condensation or Ice Build Up in Insulated Duct to the Outside	<ul style="list-style-type: none"> <li>• incomplete vapor barrier around insulated duct</li> <li>• a hole or tear in outer duct covering</li> </ul>	<ul style="list-style-type: none"> <li>• tape and seal all joints</li> <li>• tape any holes or tears made in the outer duct covering</li> <li>• ensure that the vapor barrier is completely sealed</li> </ul>
Water in the bottom of the HRV	<ul style="list-style-type: none"> <li>• drain pans plugged</li> <li>• improper connection of HRV drain lines</li> <li>• HRV is not level</li> <li>• drain lines are obstructed</li> <li>• HRV heat exchange core is not properly installed</li> </ul>	<ul style="list-style-type: none"> <li>• ensure O-Ring on drain nozzle sits properly</li> <li>• look for kinks in line</li> <li>• check water drain connections</li> <li>• make sure water drains properly from pan</li> </ul>

**1. Inspect Exterior Hoods at least once a month.**

Make sure exhaust and fresh air supply hoods are not blocked or restricted by leaves, grass, or snow. In winter, it is especially important to make sure snow is not blocking the hoods or that frost has not built up on the wire mesh (bird screen).

**WARNING:** Blockage of hoods may cause an imbalance.

**2. Clean Air Filters - Twice a Year**

The standard filters equipped with your HRV are removable and washable.

- a) simply open access door and slide core out
- b) remove filter clips
- c) once clips are removed filters can be taken off the core to be rinsed with water or a combination of mild soap and water. Do not clean in the dishwasher
- d) to re-assemble, place clean filter(s) (wet or dry) back into their positions against the core and return clips to their original position
- e) slide core back into its original position

**3. Clean Core - Twice a Year**

- a) open access door
- b) carefully grip ends of core and pull evenly outward. -core may be snug, but will slide out of the channel
- c) once removed from the cabinet remove filters
- d) wash core in warm soapy water (do not use dishwasher)
- e) install the clean filters
- f) install clean core

**Note:** Core installation label on the outer end of the core.

**To install the clean core:**

- a) first mount the bottom flange of the core guide into the bottom H channel approximately 1/4" (6mm)
- b) mount the left or right side flange of the core guide approximately 1/4" (6mm) followed by the other side
- c) mount the top flange of the core guide into the top H channel approximately 1/4" (6mm)
- d) with all four corners in place and the core straight and even, push hard in the center of the core until the core stops on the back of the cabinet

**NOTE:** Core will appear to stick out from cabinet approximately 1/8" (3mm). This is designed this way so that the access door will fit tight against the core.

**4. Motors - Maintenance Free****5. Drain (condensate) Line - Clean Once a Year**

Inspect drain line, drain spout and "P" trap for blockage, mold or kinks. Flush with warm soapy water and replace if worn, bent or unable to clean.

**6. Clean Duct System if Required**

The duct system running to and from the HRV may accumulate dirt. Wipe and vacuum the duct once every year. You may wish to contact a Heating/Ventilation company to do this.

**7. General Maintenance - Twice a Year**

Wipe down the inside of the cabinet with a damp cloth to remove dirt, bugs and debris that may be present.

**8. Cleaning the Fans**

Fans may accumulate dirt causing an imbalance and/or excessive vibration of the HRV. A reduction in the air flow may also occur. In new construction this may result within the first year due to heavy dust and may occur periodically after that over time depending on the outdoor conditions.

- unplug the HRV and open the service door
- remove the core
- remove ducting (metal and/or flexible insulated type) from the red and/or blue ports which are connected immediately inline with the fan assembly
- use a small brush, such as a toothbrush or pipe cleaner, and insert first
  - (a) through the large opening of the fan assembly and then
  - (b) through the smaller opening in the end of the fan assembly
- scrub individual fan blades until clean. Avoid moving or damaging balancing flat weight, clip is usually found on one or more of the fan blades
- vacuum and wipe
- reassemble making sure ducting is reattached firmly and insulation and moisture barrier are sealed and taped

**Before attempting this task, thought should be given to having a qualified service technician complete the service work.**