

Aprilaire®

8400 Series Thermostats



Safety & Installation Instructions

READ AND SAVE THESE INSTRUCTIONS

TABLE OF CONTENTS

INSTALLATION

Installation location recommendations	3
Outdoor temperature sensor (optional)	4
Thermostat mounting	5
Power & reset options	5
Wiring terminal	6
Wiring diagrams	7

SETUP & TESTING

System setup instructions	11
System test mode	16

REFERENCES

Quick reference to controls & display	
• Non-programmable models (8444, 8446, 8448)	22
• Programmable models (8463, 8465, 8466)	23
Thermostat features	24
Troubleshooting	25
Specifications	27

INSTALLATION

INSTALLATION LOCATION RECOMMENDATIONS

Thermostat should be mounted:

- On an interior wall, in a frequently occupied space
- Approximately 5' above floor
- At least 18" from outside wall
- Thermostat can be mounted to a vertical junction box

Do not mount thermostat:

- Behind doors, in corners, or other dead air spaces
- In direct sunlight or near lighting fixtures, or other appliances that give off heat
- On an outside or unconditioned area wall
- In the flow of a supply register, in stairwells, or near outside doors
- On a wall with concealed pipes or ductwork

INSTALLATION

OUTDOOR TEMPERATURE SENSOR (OPTIONAL)

Outdoor temperature can be measured by attaching an 8052 sensor to the S1 and S2 terminals. System setting #05 (Remote sensor) is used to enable sensor.

Heat pump models can use the outdoor temperature to effectively utilize the heat pump:

- When the outdoor temperature is less than the Low Balance Point the heat pump will be locked out and only auxiliary heating will be used.
- When the outdoor temperature is higher than the High Balance Point the auxiliary heating will be locked out and only the heat pump will be used to provide heating.

- Install on side of building out of direct sunlight (north side recommended).
- Mount above snow line.
- At least 3' away from exhaust vents and condensing lines.
- Maximum wire length is 300'.
- Do not route wires along 120 VAC lines.

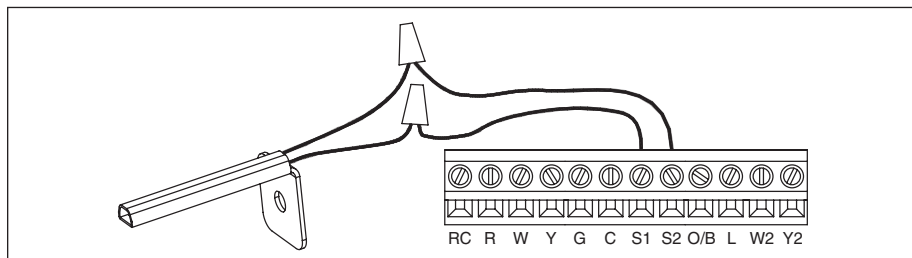

INSTALLATION

THERMOSTAT MOUNTING

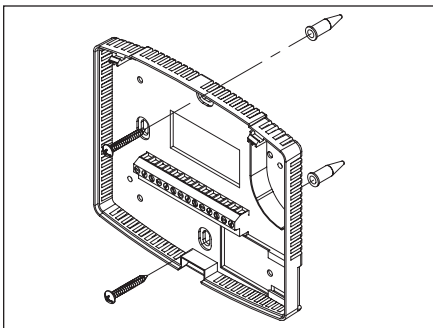

1. Remove the back of the thermostat.
2. Pull wires through the opening.
3. Position and level the back of the thermostat on wall and mark the hole locations with a pencil.
4. Drill 1/4" holes & insert supplied anchors (drywall only).
5. Place back over anchors, insert and tighten screws.
6. Seal wire entry holes to prevent drafts affecting temperature readings.

POWER & RESET OPTIONS

The thermostat is dual power. It can either be AC or battery powered, or both (to provide backup power for the clock). Batteries are optional if the thermostat was connected to AC power when installed.

For heat pump models (8446, 8348HP, 8365, 8366HP) 24 VAC must be connected in order for the system fault and emergency heat indicators to operate.

The thermostat has a memory backup that saves the thermostats settings in case of a power interruption.

The reset button located under the battery cover can be used to reset the thermostat back to factory defaults. The system settings will also be reset back to defaults.

INSTALLATION

WIRING TERMINAL

Wire specifications

18-24 gauge thermostat wire

Installation notes

- Ensure power at the HVAC equipment is off.
- Loosen screw terminals, insert stripped wire and re-tighten.
- Push the excess wire back into the opening and plug the wall opening to prevent drafts.

RC – 24 VAC supply cooling*

R – 24 VAC supply heating*

W – 1st stage heat / auxiliary

Y – 1st stage cooling / compressor

G – Fan

C – Common (optional when powered by batteries)

S1 & S2 – outdoor temperature sensor (optional)

O/B – Reversing valve

L – System fault indicator

W2 – 2nd stage heat / auxiliary

Y2 – 2nd stage cooling / compressor

**Jumper between RC & R is used in single transformer systems (see wiring diagrams).*

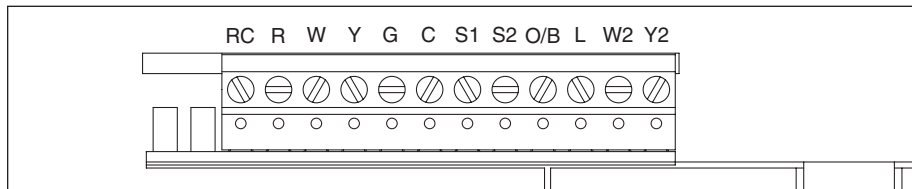

INSTALLATION

WIRING – MODEL 8463 & 8444 SINGLE TRANSFORMER (USE JUMPER WIRE)

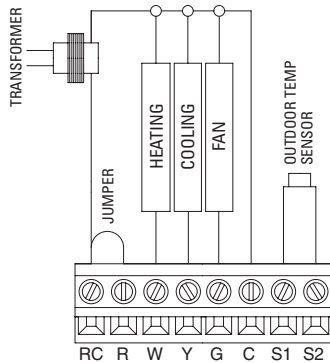

WIRING – MODEL 8463 & 8444 TWO TRANSFORMERS (REMOVE JUMPER WIRE)

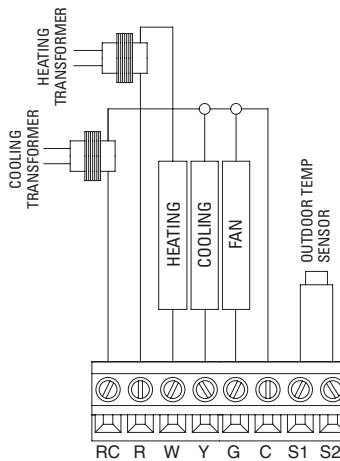

INSTALLATION

WIRING – MODEL 8465 & 8446 SINGLE TRANSFORMER (USE JUMPER WIRE)

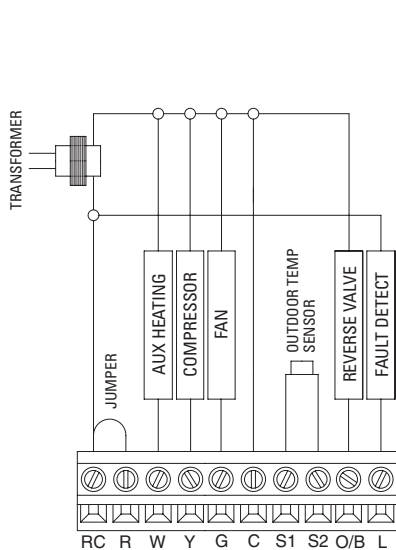

WIRING – MODEL 8465 & 8446 TWO TRANSFORMERS (REMOVE JUMPER WIRE)

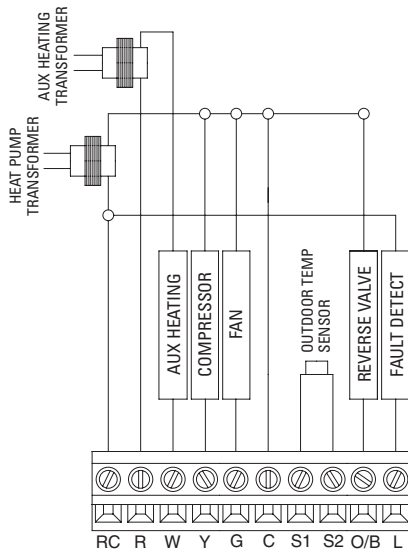

INSTALLATION

WIRING – MODEL 8466 & 8448 SINGLE TRANSFORMER (USE JUMPER WIRE) FOR HEAT/COOL SYSTEM

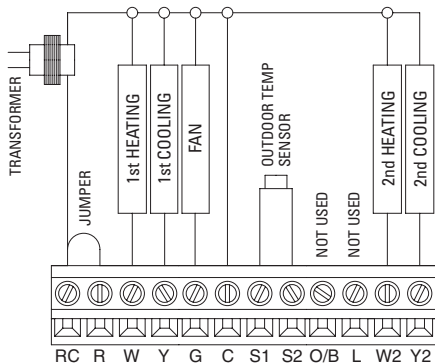

WIRING – MODEL 8466 & 8448 TWO TRANSFORMERS (REMOVE JUMPER WIRE) FOR HEAT/COOL SYSTEM

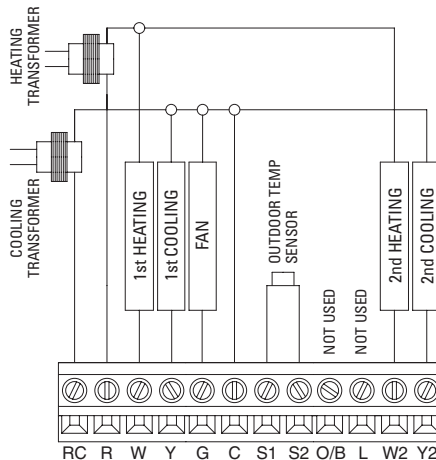

INSTALLATION

WIRING – MODEL 8466 & 8448 SINGLE TRANSFORMER (USE JUMPER WIRE) FOR HEAT PUMP SYSTEM

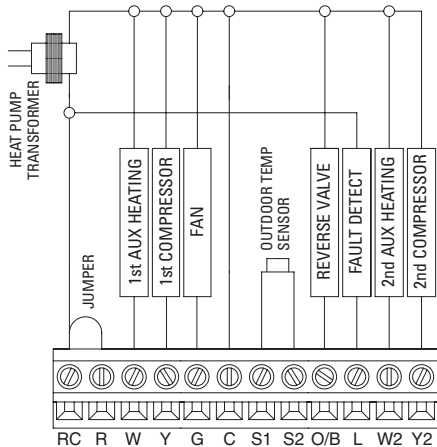

WIRING – MODEL 8466 & 8448 TWO TRANSFORMERS (REMOVE JUMPER WIRE) FOR HEAT PUMP SYSTEM

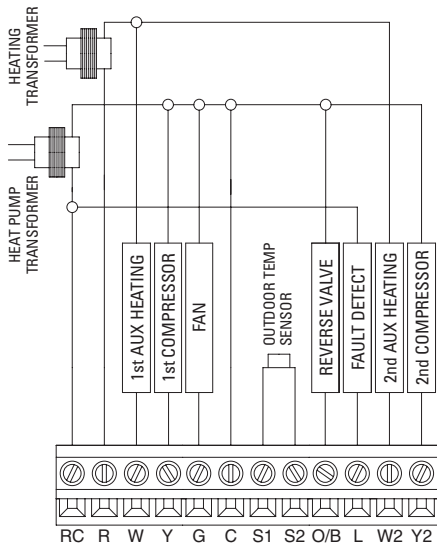

SETUP & TESTING

SYSTEM SETUP INSTRUCTIONS

The following instructions show how to enter the system setup menu and change settings. The table on the following pages lists the settings and their details. Default settings are shown in **bold**. Some settings are only available to certain models, and some are specific to thermostats set to heat pump mode.

How to enter the system setup menu to change system settings

Press **MODE** repeatedly until system is set to OFF.

Press and hold **▲** and **MODE** for three seconds.

The screen of the first setting will be displayed.

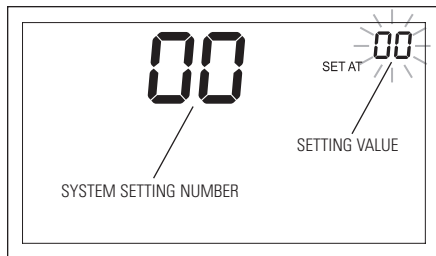

Press **▲** or **▼** to change the setting.

Press **MODE** to change to the next option.

Press **MODE** after the last setting. "DONE" will be displayed.

The thermostat will return to Normal mode if no key is pressed in 3 seconds.

To reset all system settings back to default, press the **RESET** button located under the battery door.

SETUP & TESTING

SYSTEM SETUP INSTRUCTIONS (CONTINUED)

Thermostat models 8448 & 8466 have the option of being used in heat pump or heat/cool systems. Switch SW1 located on the back of the thermostat's face is used to select this. System setting number 00 will only be shown on these models to display the position of SW1.

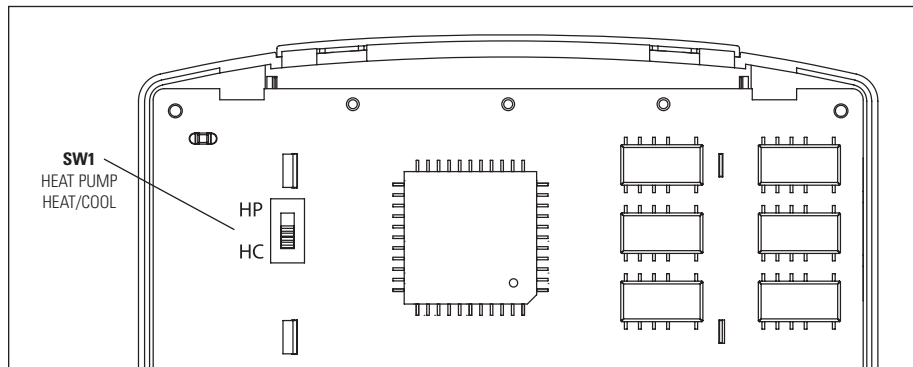

SETUP & TESTING

SYSTEM SETUP INSTRUCTIONS (CONTINUED)

System setting	Setting range, default in bold
00 Equipment type (8466, 8448) (Set by SW1)	0 : heat/cool 1 : heat pump
01 Temperature scale	0 : Fahrenheit 1 : Celsius
02 Fan control in heating	0 : Gas or oil furnace (Equipment controls fan) 1 : Electric (Thermostat controls fan)
03 Offset for internal sensor	0° : No offset applied -4°F to +4°F (-2°C to +2°C)
04 Auto mode	0 : Auto mode is disabled 1 : Auto mode is enabled
05 Remote sensor	0 : No remote sensor attached 1 : Remote sensor attached
06 Compressor minimum off time	5 minutes 1 to 5 minutes in 1 minute steps
07 Heating minimum off time	2 minutes 1 to 5 minutes

SETUP & TESTING

SYSTEM SETUP INSTRUCTIONS (CONTINUED)

System setting	Setting range, default in bold
08 Equipment minimum on time	2 minutes 1 to 5 minutes
09 1st stage differential	1°F (0.5°C) 1°F to 4°F (0.5°C to 2°C)
10 2nd stage differential (8448, 8466)	1°F (0.5°C) 1°F to 4°F (0.5°C to 2°C)
11 3rd stage differential (8448HP, 8466HP)	1°F (0.5°C) 1°F to 4°F (0.5°C to 2°C)
12 Reverse valve (8446, 8466HP, 8465, 8466HP)	0 – O/B energized in cooling (0) 1 – O/B energized in heating (B)
13 Integral factor period (P+I control) *Set to OFF for proportional control only	4 minutes 1 to 5 minutes or "OFF" to disable
14 Deadband (auto mode)	3°F (2°C) 2°F to 5°F (1°C to 3°C)
15 Progressive recovery (8463, 8465, 8366)	0 : Progressive recovery is disabled 1 : Progressive recovery is enabled

SETUP & TESTING

SYSTEM SETUP INSTRUCTIONS (CONTINUED)

System setting	Setting range, default in bold
16 Low Balance Pt. (8446, 8448HP, 8465, 8466HP)	20°F (-7°C) 1°F to 35°F (-17°C to 2°C) or "OFF" to disable
17 High Balance Pt. (8446, 8448HP, 8465, 8466HP)	60°F (16°C) 40°F to 80°F (4°C to 27°C) or "OFF" to disable
19 Program format (8463, 8465, 8366)	0 – 5/2 program (Weekdays and Weekends) 1 – 5/1/1 program (Weekdays, Sat. and Sun.)
20 Change air filter	OFF 1, 3, 6, 12 months or "OFF" to disable
21 Change water panel *Set number of months until reminder is required	OFF 1 to 12 months or "OFF" to disable
22 Humidifier type	0 : Flow through type humidifier (1 reminder per season) 1 : Drain-less type humidifier (2 reminders per season)
23 Service dehumidifier	OFF 1 to 12 months or "OFF" to disable
24 Service HVAC	OFF 1 to 12 months or "OFF" to disable

SETUP & TESTING

SYSTEM TEST MODE

The system test mode is used to test a system after installation. The outputs of the thermostat can be manually activated one at a time to test their function. The following instructions show how to enter the test mode and turn outputs on and off. The chart on the following pages shows all of the options for each model.

The test steps are:

Test Number	Heat/Cool Models 8444, 8463, 8448HC, 8466HC	Heat Pump Models 8446, 8465, 8448HP, 8466HP
50	Heating (W) (W2)	Aux Heating (W) (W2)
51	Cooling (Y) (Y2)	Compressor Cooling (Y) (Y2)
52	Fan (G)	Compressor Heating (Y) (Y2)
53		Fan (G)

SETUP & TESTING

SYSTEM TEST MODE (CONTINUED)

How to enter the system test menu

Press **MODE** repeatedly until system is set to OFF

Press and hold **▲** and **FAN** for three seconds.

The screen of the first test step #50 is displayed:

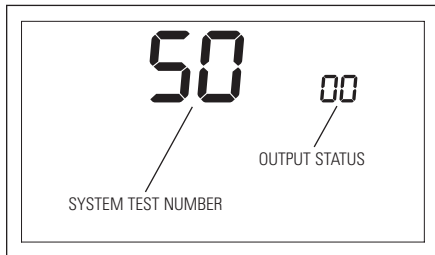

Press **▲** to turn on the output (01). For multi stage output, **press ▲** again to turn on the 2nd stage (02).

Press **▼** to turn off the output (00).

Press **MODE** to change to the next test step.

Press **MODE** after the last test step. "DONE" will be displayed.

The thermostat will return to Normal mode if no key is pressed in 3 seconds.

SETUP & TESTING

Test steps for 8444 & 8463									
Step	Key Input	System Setting		Display (Output)					
		#2		01 HEATING ON (W)		01 COOLING ON (Y)		01 FAN ON (G)	
#50 Heat	[UP]	0 : Gas		ON					
	[DOWN]	1 : Elec		ON				ON	
#51 Cool	[UP]					ON		ON	
	[DOWN]								
#52 Fan	[UP]							ON	
	[DOWN]								

SETUP & TESTING

Test steps for 8448HC & 8466HC									
Step	Key Input	System Setting		Display (Output)					
		#2		01 HEATING ON (W)	02 HEATING ON (W2)	01 COOLING ON (Y)	02 COOLING ON (Y2)	01 FAN ON (G)	
#50 Heat	1st [UP]	0 : Gas		ON					
		1 : Elec		ON				ON	
	2nd [UP]	0 : Gas		ON	ON				
		1 : Elec		ON	ON				ON
[DOWN]									
#51 Cool	1st [UP]					ON		ON	
	2nd [UP]					ON	ON	ON	
	[DOWN]								
#52 Fan	[UP]							ON	
	[DOWN]								

SETUP & TESTING

Test steps for 8446 & 8465									
Step	Key Input	System Setting		Display (Output)					
		#2	#12	01 AUX HEATING ON (W)		01 COOL/HEAT ON (Y)		01 FAN ON (G)	O/B
#50 Aux	[UP]	0 : Gas		ON					
		1 : Elec		ON				ON	
	[DOWN]								
#51 Cool	[UP]		0 : 0			ON		ON	ON
			1 : B			ON		ON	
	[DOWN]		0 : 0						ON
			1 : B						
#52 Heat	[UP]		0 : 0			ON		ON	
			1 : B			ON		ON	ON
	[DOWN]		0 : 0						
			1 : B						ON
#53 Fan	[UP]							ON	
	[DOWN]								

SETUP & TESTING

Test steps for 8448HP & 8466HP									
Step	Key Input	System Setting		Display (Output)					
		#2	#12	01 AUX HEATING ON (W)	02 AUX HEATING ON (W2)	01 COOL/HEAT ON (Y)	02 COOL/HEAT ON (Y2)	01 FAN ON (G)	O/B
#50 Aux	1st [UP]	0 : Gas		ON					
		1 : Elec		ON				ON	
	2nd [UP]	0 : Gas		ON	ON				
		1 : Elec		ON	ON			ON	
[DOWN]									
#51 Cool	1st [UP]	0 : 0				ON		ON	ON
		1 : B				ON		ON	
	2nd [UP]	0 : 0				ON	ON	ON	ON
		1 : B				ON	ON	ON	
[DOWN]	0 : 0							ON	
	1 : B								
#52 Heat	1st [UP]	0 : 0				ON		ON	
		1 : B				ON		ON	ON
	2nd [UP]	0 : 0				ON	ON	ON	
		1 : B				ON	ON	ON	ON
[DOWN]	0 : 0								
	1 : B							ON	
#53 Fan	[UP]							ON	
	[DOWN]								

QUICK REFERENCE TO CONTROLS & DISPLAY

NON-PROGRAMMABLE MODELS (8444, 8446, 8448)

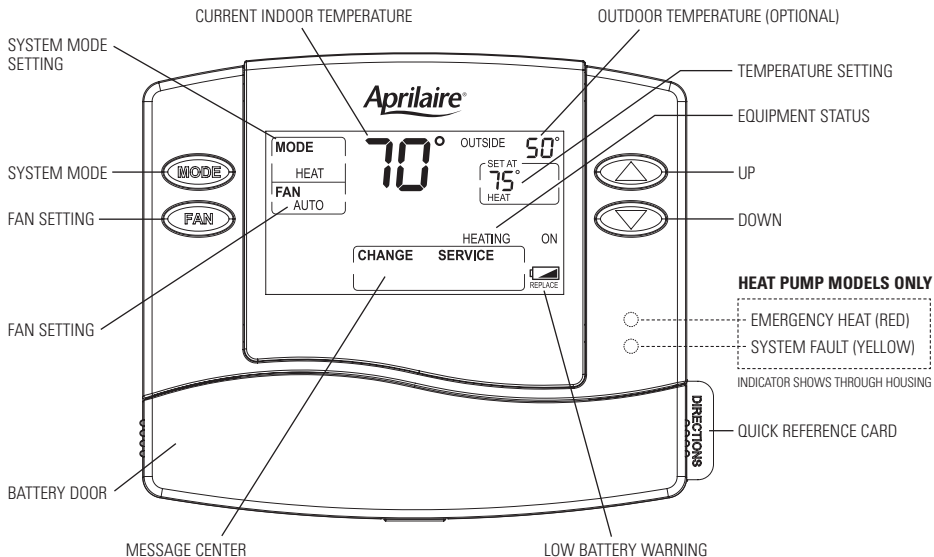

NOTE: BACKLIGHT IS ACTIVATED WITH FIRST BUTTON PRESS AND AUTOMATICALLY TURNS OFF AFTER 10 SECONDS.

QUICK REFERENCE TO CONTROLS & DISPLAY

PROGRAMMABLE MODELS (8463, 8465, 8466)

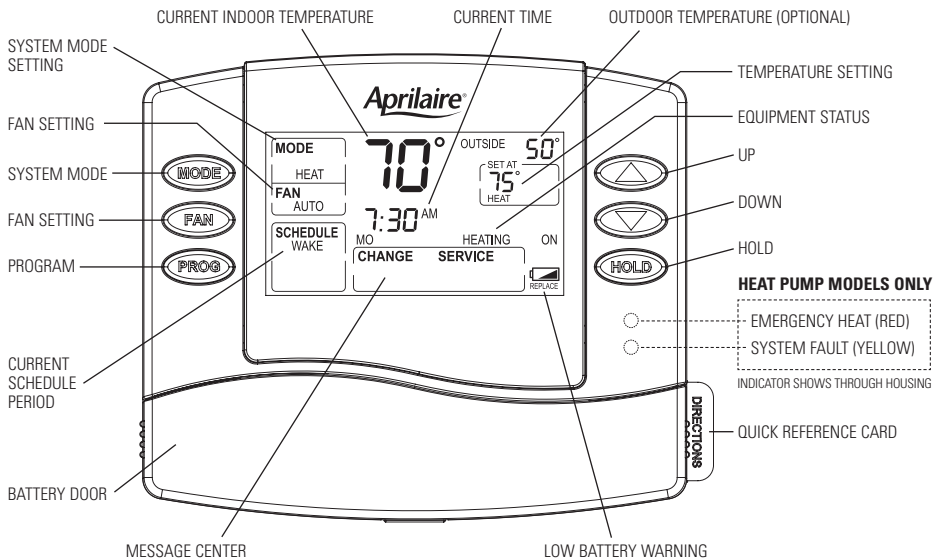

NOTE: BACKLIGHT IS ACTIVATED WITH FIRST BUTTON PRESS AND AUTOMATICALLY TURNS OFF AFTER 10 SECONDS.

THERMOSTAT FEATURES

ALL 8400 SERIES THERMOSTATS

- Large, clear, backlit display is easy to read – even in the dark
- Displays room temperature, temperature setting, and optional outdoor temperature
- Dual power option (Battery or 24 VAC)
- Removable battery holder for fast, easy replacement
- Built in compressor protection
- Circulation fan mode filtering
- Water panel, dehumidifier, air filter, and HVAC service indicators
- System test mode

PROGRAMMABLE MODELS ONLY (8463, 8465, 8466)

- Separately programmable weekday/weekend schedules
- Easy to use temperature control can override program schedule at any time
- EnergyStar® compliant to greatly reduce your heating/cooling expenses
- Progressive recovery

TROUBLESHOOTING

DISPLAY IS BLANK

- Check circuit breaker and reset if necessary.
- Make sure power switch at heating & cooling system is on.
- Make sure furnace door is closed securely.
- If thermostat is battery powered, make sure fresh AA alkaline batteries are correctly installed.

TEMPERATURE SETTINGS DO NOT CHANGE

Make sure heating and cooling temperatures are set to acceptable ranges:

- **Heat:** 45° to 90°F (7° to 32°C).
- **Cool:** 50° to 99°F (10° to 37°C).

HEATING SYSTEM DOES NOT RESPOND ("HEATING" APPEARS ON SCREEN)

- Check for 24 VAC at the equipment on the secondary side of the transformer between power and common. If voltage is not present, check the heating equipment to find the cause of the problem.
- Check for 24 VAC between the heat terminal (W) and the transformer common. If 24 VAC is present, the thermostat is functional. Check the heating equipment to find the cause of the problem.
- Check for loose or broken wires between the thermostat and the heating equipment.

TROUBLESHOOTING

COOLING SYSTEM DOES NOT RESPOND ("COOLING" APPEARS ON SCREEN)

- Check for 24 VAC at the equipment on the secondary side of the transformer between power and common. If voltage is not present, check the cooling equipment to find the cause of the problem.
- Check for 24 VAC between the cooling terminal (Y) and the transformer common. If 24 VAC is present, the thermostat is functional. Check the cooling system to find the cause of the problem.
- Check for loose or broken wires between the thermostat and the cooling equipment.

FAN DOES NOT TURN ON IN A CALL FOR HEAT

- Check System Setting #02 (Fan Control), to make sure the fan control is properly set to match the type of system (see page 11).

HEAT PUMP ISSUES COOL AIR IN HEAT MODE, OR WARM AIR IN COOL MODE

- Check System Setting #12 (Reversing Valve), to make sure it is properly configured for your system (see page 11).

HEAT/COOL BOTH ON AT SAME TIME

- Check SW1 (Equipment Type), to make sure it is set to match the installed heating/cooling equipment (see page 12).
- Check to make sure heating and cooling wires are not shorted together.

HEATING EQUIPMENT IS RUNNING IN COOL MODE

- Check SW1 (Equipment Type), to make sure it is set to match the installed heating/cooling equipment (see page 12).

"HEATING" IS NOT DISPLAYED

- Change the System Mode to Heat, and set the temperature level above the current room temperature.

"COOLING" IS NOT DISPLAYED

- Change the System Mode to Cool, and set the temperature level below the current room temperature.

SPECIFICATIONS

Environment	
Temperature	Operating: 32° to 120°F (0° to 48.9°C) Shipping: -30° to 140°F (-34.4° to 60°C)
Relative humidity	Operating: 5% to 90% R.H. (non-condensing)

Electrical	
Operating voltage	24 VAC (18 – 30 VAC)
Current	Maximum: 2.5A (total), 1.0A (single output) Maximum surge current: 5A
Power supply	Dual power. Can be battery or 24 VAC powered. When both the sources are available, battery will be used as back up power.
Battery power	Battery power: AA size alkaline battery x 2 Battery life: Approximately 1 year

SPECIFICATIONS

Thermal	
Outdoor temperature sensor	Maximum distance: 300 feet
Room temperature measurement	Display range: 32° to 99°F (0° to 40°C)
Outdoor temperature measurement	Display range: -20° to 130°F (-30° to 55°C)
Temperature setting range	Heat: 45° to 90°F (7° to 32°C) Cool: 50° to 99°F (10° to 37°C)

RESEARCH PRODUCTS CORPORATION
P.O. BOX 1467 • MADISON, WI 53701-1467 • www.aprilaire.com

61000652 5.09
B2204777A