

INTRODUCTION

The Everpure MRS (Mineral Reduction System) is a pre-engineered, pre-assembled Reverse Osmosis (RO) system designed to provide high purity water for many applications, such as premium espresso, coffee and blended beverages, to name a few. It combines a number of water treatment technologies into one easy to install package. The system provides superior protection against taste and odor causing contaminants while removing dirt, particulates and dissolved solids that can foul or scale equipment.

Initial System Production

Water production depends on supply water pressure and temperature. See PERFORMANCE section (page 5) for normalized production.

Influent Water Characteristics

The following table lists the allowable operating range of various water properties within which the MRS will function properly.

Total Dissolved Solids (TDS)	0-1500 PPM (0-1500 mg/L)
pH	5-10
Chlorine ¹	0-3 PPM (0-3 mg/L)
Chloramines	0-3 PPM (0-3 mg/L)
Turbidity	0-1 NTU
Iron	0-1 PPM (0-1 mg/L)

¹ Reverse osmosis membrane filter used in this system will be damaged by chlorine. An activated carbon filter has been provided with this system to protect the reverse osmosis membrane from chlorine attack. Influent chlorine should not exceed 3 mg/L.

The complete MRS consists of 5 major components:

1. Inlet booster pump.
2. 5-Micron Pre-filter (optional).
3. Granular Activated Carbon Taste & Odor (TO) cartridge.
4. Reverse Osmosis (RO) membrane cartridge.
5. Calcium carbonate (CC) re-mineralization cartridge (optional).

The optional 5-micron pre-filter removes suspended particles, which can lead to pre-mature plugging of the TO and/or RO membrane cartridge. The TO cartridge removes most oxidizers, but mainly reduces chlorine, preventing damage to the RO cartridge. The RO cartridge contains a semi-permeable reverse osmosis membrane. Here, most dissolved impurities are separated from the water and flushed down the drain. The water that is able to pass through the membrane, which is very low in dissolved impurities, is referred to as permeate, RO water, or product water. Depending on the model, the permeate will do one of the following:

- Systems without calcium carbonate (CC) cartridge - The permeate will pass through the cartridge head with by-pass plug, exiting to service and/or enters the optional storage tank.
- Systems with calcium carbonate (CC) cartridge - The permeate will pass through calcium carbonate cartridge, where re-mineralization occurs. This cartridge reintroduces a metered amount of TDS level of the RO permeate. After remineralization, the treated water exits to service and/or enters the optional storage tank.

The optional storage tank stores water that has been produced by the RO System. This provides a water supply "buffer", enabling the system to provide reasonable volumes of product water during high demand periods.

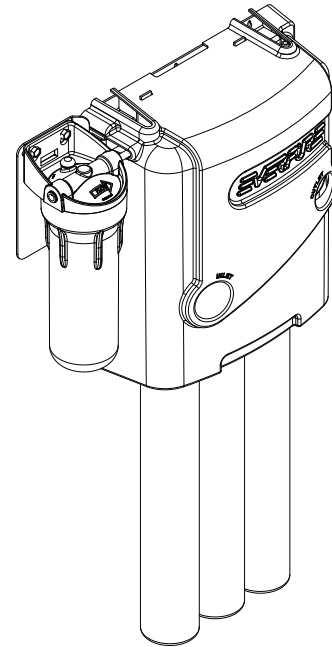

A unique cartridge monitor/alarm module is available. This device can be set to provide simultaneous water throughput and operating time indications over easily selectable ranges. This monitor helps in determining cartridge change-out schedules.

OPERATING SPECIFICATIONS

- Dynamic Operating Pressure: 25–80 psi (1.7–5.5 bar)
- Static Operating Pressure: 100 psi (6.9 bar)
- Operating Temperature 40–100°F (4.4–37.8°C)
- Connections
 - Inlet/Outlet: 3/8-inch tube
 - Concentrate: 1/4-inch tube
- Electrical
 - Voltage: 115 volt AC
 - Hertz: 60
 - Phase: 1
 - Ampere: 1.5
 - Branch Circuit Protection: 15 or 20 AMP Ground Fault Protected

Pre-Installation Checklist

1. _____ Can the unit be mounted within a reasonable distance of the water supply and drain facilities?
2. _____ Is there an un-switched 115 VAC GFIC (ground fault interrupter circuit) protected receptacle available for powering the system?
3. _____ Is there adequate clearance and support to install the unit and permit access for maintenance? The total system weight will vary based on model and storage tank selected. See specification table for approximate operating weights.
4. _____ Does the inlet water supply meet the requirements listed below?
 - a. A minimum of 25 PSI pressure on a consistent basis
 - b. Less than 1,500 ppm of Total Dissolved Solids (TDS)
 - c. Less than 10 GPG of water hardness
 - d. pH level between 7.0-9.0
 - e. Turbidity less than 1 NTU

NOTES:

- Please read this manual prior to installing and operating the system.
- Incoming water supplies that do not meet these requirements may need additional pre-treatment prior to the system. System performance may be affected if requirements are not met, including system output production and cartridge change-out frequency.
- If the supply pressure exceeds 80 PSI, install a pressure reducing valve. Adjust the pressure reducing valve to the required operating pressure, not to exceed 80 PSI.
- Consult with your local building inspector for approval and required permits to install this system. Additional equipment, such as back-flow prevention devices, seismic restraint equipment, air gaps, etc., may be required. Completed installation must meet all local and national codes.

Do not connect the MRS system after any water filtration system, unless specifically provided for use with the MRS.

UNPACKING AND INSPECTION

The MRS includes all the necessary fittings for installation. Lengths of 1/4" tubing have been provided for connecting to the wastewater/drain connection. Supply lines and distribution piping/tubing are not included.

The MRS system is packaged as a complete unit in two cartons. At a minimum, you should have the following:

Carton 1

1. Plate mounted processor assembly (Including the following)
 - A. pump
 - B. cartridge heads
 - C. transformer

Carton 2

1. TO cartridge
2. RO cartridge
3. Calcium carbonate (CC) cartridge (optional)

Inspect the cartons for damage. Report any damage to freight carrier immediately. Carefully unpack each item. Save the packaging material temporarily, as it may be used to protect painted surfaces during assembly.

SYSTEM ASSEMBLY

The MRS is configured as a two piece unit; with the processor mounted on a vertical surface and the storage tank located nearby.

Locate the system in an area that is convenient to the inlet water supply and drain facilities, with access for routing the product water tubing/piping to the equipment. Install in a dry location, away from all forms of corrosive and/or flammable materials. Consider ease of access for servicing when selecting a location.

Processor Assembly Mounting

1. If the optional Pre-filter has been supplied, go to step 2. If not supplied, go to step 5.
2. Position the MRS processor assembly so the rear of the mounting plate is accessible. Secure the wing bracket to the rear of the mounting plate as shown Figure 1. Use the 5/16" hex bolts and washers provided. Align the wing bracket so it is inward and upward as far as possible – use a combination square to maintain alignment. Tighten both bolts securely.
3. Attach Pre-filter head to Pre-filter bracket with 5/16" hex bolts, nuts and washers provided.
4. Insert elbow fitting into solenoid valve inlet. Connect 1/4" OD tubing between pre-filter outlet and elbow fitting on solenoid valve.
5. The processor framework has 6 mounting holes (3 keyhole slots, 3 standard) on 4.5" centers for securing to a stationary vertical surface. Evaluate the mounting surface for its ability to properly support the weight of the processor when in operation (Approximately 40 pounds).

continued on the next page ...

Figure 1. Back view of Prefilter bracket.

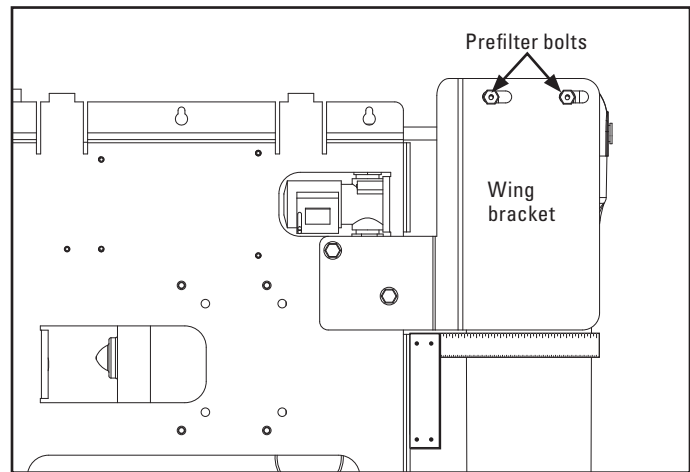
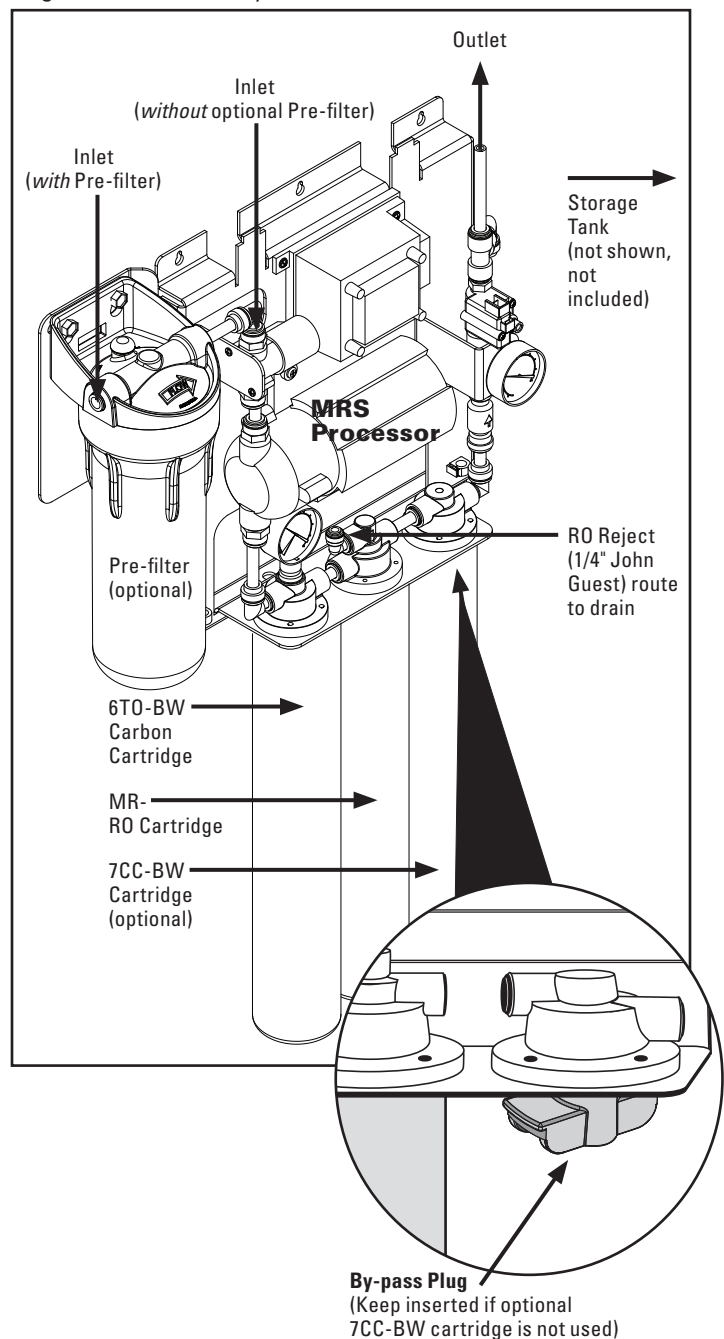

Figure 2. MRS Assembly.



- Attach processor to the vertical surface with screws and anchors designed for the mounting surface material.

⚠ WARNING Do not use screws smaller than #12 for mounting the processor.

⚠ WARNING Mounting surface may require reinforcement to support processor safely. Hollow walls, drywall and other non-structural surfaces are not suitable unless reinforced.

Piping/Tubing Connections

- Refer to Figure 2 for views of the piping, with a description of major components and connection points. These major components and connections will be referred to in the following steps.
- Prepare the plumbing to accept the RO system. It is recommended that a three valve by-pass is installed to provide an uninterrupted supply of water when the RO system requires service.

Note: The product water tubing/piping and associated fittings connecting the RO product outlet to the equipment being serviced should be food grade material that meets NSF Standard 51 or 61 with a minimum pressure rating of 75-PSI. The product water will react with most metal piping, creating a corrosive condition, in addition to imparting an objectionable taste. Plastic pipe or reinforced tubing are generally very good choices for RO water distribution materials. The size of the product water tubing/piping should be 3/8" ID minimum. Distances of 25 feet or greater from the RO to the equipment being serviced should be 1/2" ID minimum.

- Connect the inlet supply.
 - MODELS WITHOUT PRE-FILTER** – See Figure 3. Connect to the Inlet open port (3/8" JG) on the solenoid valve.
 - MODELS WITH PRE-FILTER** – See Figure 4. Connect to the Inlet open port (3/8" JG) on the pre-filter head.
- Connect the appropriate size and type of tubing/piping and associated fittings to the Outlet tee connection. Route the line(s) to the equipment being serviced (i.e.; espresso, coffee, etc.).
- Locate the storage tank directly below or adjacent to the processor assembly. Be sure the mounting surface is capable of supporting the weight of the tank when full (see specification table for operating weights). Connect a suitable length of 3/8" inch OD tubing to the tank connection. Route this section of tubing to the main processor assembly. Connect the tubing to the elbow fitting attached to the side of the outlet tee connection.

Note: The storage tank pre-charge pressure should be checked and adjusted when the storage tank is empty. For most applications, a low (5-10 psi) pre-charge pressure is recommended, to attain maximum storage tank volume.

- Close the inlet, outlet and by-pass ball valves.
- Locate the correct reject flow control assembly based on the illustration below (A). Insert the reject flow control assembly into the 1/4" OD tube (See A Below). Insert the 1/4" OD tube with reject flow control assembly into the elbow fitting on RO head (See B below). Route the other end of the tubing to a drain nearby, securing it temporarily. Allow an air gap at the drain, following any applicable local codes. See Figure 5.

continued on the next page ...

Figure 3. No Prefilter

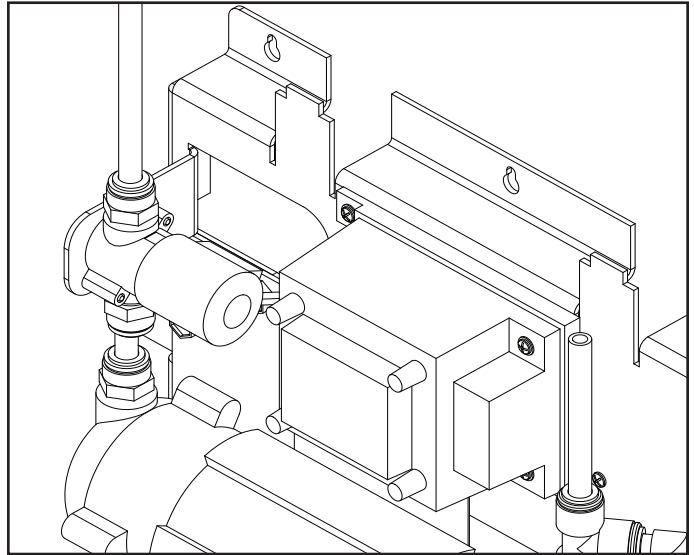

Figure 4. Pre-filter

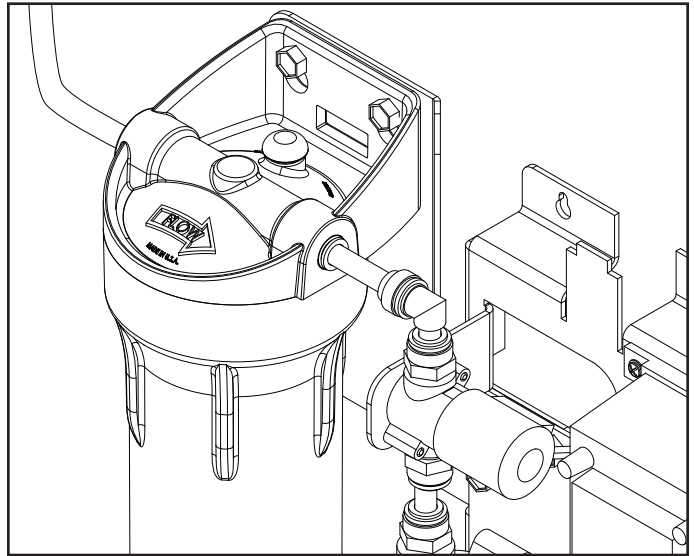
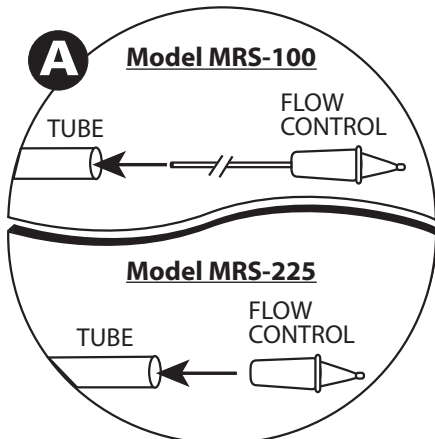
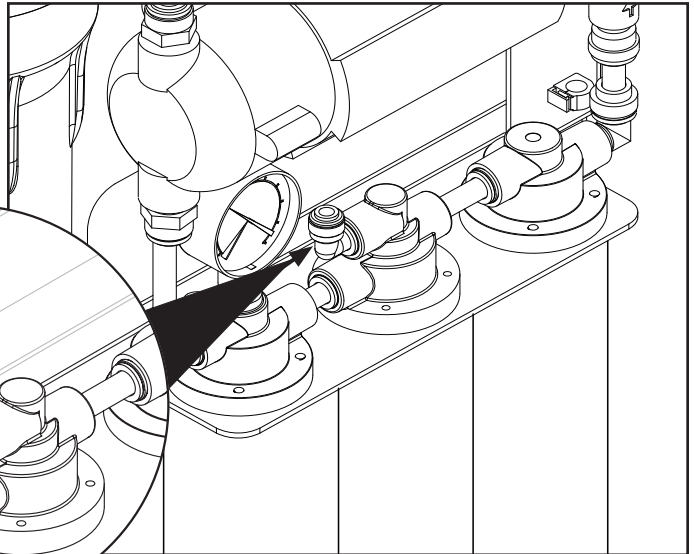

Figure 5. RO Reject Flow Control Assembly



⚠ WARNING Refer to *Reject to Drain, Maximum* under *RO Production* in the Performance Table (page 5) to determine the maximum gallon per minute waste flow rate. Verify drain has ample capacity for this waste flow, plus all other sources of waste flow sharing this drain.

Electrical Connections

The system is pre-wired at the factory. Verify that a 115 VAC ground fault protected circuit rated at 15 Amps minimum is located nearby. Plug-in power cord when instructed to do so in the following section.

CARTRIDGE INSTALLATION AND ACTIVATION

1. Remove the outer shrink-wrap and protective closure from the pre-filter (optional), TO, RO cartridge and CC cartridge (optional).
2. If the optional Pre-filter has been supplied, go to step to 3. If not supplied, go to step 4.
3. Locate the sump (clear bowl) for the pre-filter housing. Install the pre-filter cartridge into the sump. Locate the O-ring in the small parts pack. Lightly lubricate this O-ring with a food grade lubricant and install it into the groove in the sump. Install the sump with pre-filter and O-ring into the pre-filter head. Use the sump wrench to tighten the sump securely.
4. Install the TO cartridge into the TO head, following the instructions on the cartridge.
5. Slowly open the inlet supply valve. Position a bucket underneath the RO cartridge head to collect water. Apply power to the system by plugging the power cord into the receptacle. Within moments, water should begin to spill out of the RO head and into the bucket. Carbon fines and air will be flushed out of during this time. Flush until water runs clear (3-5 minutes typically). If the bucket requires emptying, un-plug the power cord from the receptacle to stop the flow, then empty the bucket. Reposition the bucket and repeat the flushing operation as required. Once the TO cartridge has been flushed, un-plug the power cord from the receptacle.
6. Install the RO cartridge into the RO head, following the instructions on the cartridge.
7. If the optional CC cartridge has been supplied, go to step to 8. If not supplied, go to step 9.
8. Remove the plug from the CC cartridge head. Install the CC cartridge into the head, following the instructions on the cartridge.
9. Disconnect the tubing connecting the storage tank to the system and route to a drain temporarily.

⚠ WARNING Do not use this product water! It may contain a preservative solution from the RO cartridge and should not be consumed!

10. Apply power to the system by plugging the power cord into the receptacle. Within moments, water should begin to exit the storage tank tubing. Allow the system to flush for at least 1 hour or until 5 gallons of product water has been produced. Un-plug the power cord. Re-connect the tubing to the storage tank.

DISINFECTION

When flushing is complete, the storage tank and associated piping must be disinfected, and then completely flushed. The steps for this are outlined below.

1. Locate the 3/8" OD tubing that connects to the storage tank. Disconnect the end which connects to the elbow fitting at the processor. Measure 1 ounce of 5.25% bleach for every 7.5 gallons of storage tank capacity. Pour this volume of bleach into the tube that leads to the storage tank. Re-connect this tube to the elbow fitting. Apply power to the system by plugging the power cord into the receptacle. The booster pump should begin to run and fill the storage tank.

2. Once sufficient water has entered the storage tank (more than 1/4 full), demand treated water from at least one piece of equipment the MRS is supplying water to. Once all of the air has been purged, and a solid flow of water is observed, stop the flow at the connected equipment. Purge the air from all remaining pieces of connected equipment by demanding water from each one individually.
3. Allow the storage tank to fill until the booster pump turns off. Allow the chlorinated water to remain in the storage tank and distribution piping for 10 minutes.
4. Un-plug the power cord. Drain the storage tank by demanding water downstream and allow the storage tank to drain. Once the storage tank is empty, stop demanding water downstream.
5. Apply power to the system by plugging the power cord into the receptacle. Once sufficient water has entered the storage tank (more than 1/4 full), demand treated water from at least one piece of equipment the MRS is supplying water to. After 5 minutes, stop the flow at the connected equipment. Flush the lines to each remaining piece of connected equipment by demanding water from them for 2 minutes each.
6. Allow the storage tank to fill until the booster pumps turns off.
7. Un-plug the power cord. Drain the storage tank by demanding water downstream and allow the storage tank to drain. Once the storage tank is empty, stop demanding water downstream.
8. Repeat steps 5-7 until no residual chlorine odor is detected from the water exiting the storage tank drain valve or connected equipment.

PLACING THE MRS INTO SERVICE

Once the cartridges have been activated, the storage tank & distribution piping sanitized, the MRS can be placed into service.

During normal operation, the valves on the MRS should be in the following positions:

- A. System inlet and outlet valves – open
- B. System by-pass valve – closed.

Once the system been started-up initially, it is a good idea to measure the outlet water flow rate and quality to verify the system's performance. The initial values should be recorded for future comparison to detect any changes in performance. A Performance Log has been provided on Page 6 to record this information.

OPERATION

1. During normal operation, a continuous supply of water must be available to the system.
2. The system inlet and outlet valves must be open, the sample outlet and flushing valves must be closed and the drain line must be unrestricted.

PERFORMANCE* SECTION

RO Production†	MRS-100 EV9970-07	MRS-225 EV9970-08	MRS-100CC EV9970-10	MRS-225CC EV9970-09
Gallons per Day	100 gpd	225 gpd	100 gpd	225 gpd
Gallons per Hour	4.17 gph	9.38 gph	4.17 gph	9.38 gph
Ounces per Minute	8.9 opm	19.9 opm	8.9 opm	19.9 opm
Inlet Supply Requirements, Minimum	0.3 gpm	0.6 gpm	0.3 gpm	0.6 gpm
Reject to Drain, Maximum	0.2 gpm	0.4 gpm	0.2 gpm	0.4 gpm

†Production rates based on the following:
750 ppm TDS Soft Water @ 50 psi, 77°F, to Atmosphere, Recovery = 25%, SDI = <3,

Stored Water System	MRS-100 EV9970-07	MRS-225 EV9970-08	MRS-100CC EV9970-10	MRS-225CC EV9970-09
Flowrate (gpd)	Dependant on: Pressure/volume in storage, line sizes			
Volume (Gallons)	Dependant on: Pressure/volume in storage			
Pressure (typical)	25–40 psi (1.7–2.8 bar)			
Salt Rejection	90% minimum			
Recovery	25% typical			

DIMENSIONS AND OPERATING WEIGHTS

Tank Only	MRS-100 EV9970-07	MRS-225 EV9970-08	MRS-100CC EV9970-10	MRS-225CC EV9970-09
3 Gallon	17"H x 11"W x 11"D 40 lbs			
15 Gallon	26.5"H x 16"W x 15"D 140 lbs			
20 Gallon	32.25"H x 16"W x 16"D 190 lbs			
30 Gallon	44"H x 16"W x 16"D 270 lbs			
40 Gallon	56.75"H x 16"W x 16"D 370 lbs			
80 Gallon	55.5"H x 24.25"W x 24.25"D 790 lbs			

MRS Processor only	MRS-100 EV9970-07	MRS-225 EV9970-08	MRS-100CC EV9970-10	MRS-225CC EV9970-09
Without Pre-Filter	30"H x 15"W x 8"D 35 lbs		34"H x 15"W x 8"D 35 lbs	
With Optional Pre-Filter	30"H x 20.5"W x 8"D 40 lbs		34"H x 20.5"W x 8"D 40 lbs	

Cartridges and Elements		MRS-100 EV9970-07	MRS-225 EV9970-08	MRS-100CC EV9970-10	MRS-225CC EV9970-09
Pre-Filtration	Sediment (Optional)	5 Micron, 10-inch, Spun Polypropylene			
	Organic Reduction	16-inch, Granular Activated Carbon (GAC)			
Reverse Osmosis		16-inch TFC			
Blended and/or Filtered Water (Optional)		NA		20-inch	

*Specifications Subject To Change Without Notice.

TROUBLESHOOTING GUIDE

Problem	Possible Cause	Remedy
1. Insufficient product water during normal operating periods.	a. Pre-filter cartridge plugged.	a. Replace pre-filter cartridge.
	b. TO cartridge plugged.	b. Replace TO cartridge.
	c. RO cartridge plugged.	c. Replace RO cartridge.
	d. Insufficient system inlet pressure.	d. Check/repair booster pump and inlet line.
	e. Incorrect storage tank pre-charge.	e. Empty water in storage tank. Check pre-charge pressure. Adjust to 5-10 psi (typical). Presence of water at Schrader valve indicates failed bladder - Replace bladder or tank.
2. Insufficient product water volume during peak periods.	a. Refer to problem 1.	a. Refer to problem 1.
	b. System rated output low for application.	b. Verify system output. If output is within specification, increase output if applicable.
	c. System storage capacity low.	c. Increase storage capacity if applicable.
3. Low quality RO water.	a. Refer to problem 1.	a. Refer to problem 1.
	b. RO cartridge failure.	b. Replace RO cartridge.
4. Low water pressure at water using equipment.	a. Tubing/piping run to equipment restrictive.	a. Increase tubing/piping diameter. Refer to "System Installation" section for recommendations.
	b. Incorrect storage tank pre-charge.	b. Empty water in storage tank. Check pre-charge pressure. Adjust to 5-10 psi (typical). Presence of water at Schrader valve indicates failed bladder - Replace bladder or tank.
5. Objectionable product water odor.	a. TO cartridge exhausted.	a. Replace TO cartridge.
	b. Storage Tank requires disinfection.	b. Disinfect storage tank.
6. Wastewater flow too low or decreases over time.	a. Drain line restricted.	a. Check/correct any restrictions in drain line tubing. Make sure to allow an air gap at the drain. Disconnect reject line at quick connect fitting and inspect for obstruction or damage. Remove obstruction. Replace if required.
	b. Insufficient system inlet pressure.	b. Check/repair booster pump and inlet line.

Figure 6. Parts Diagram

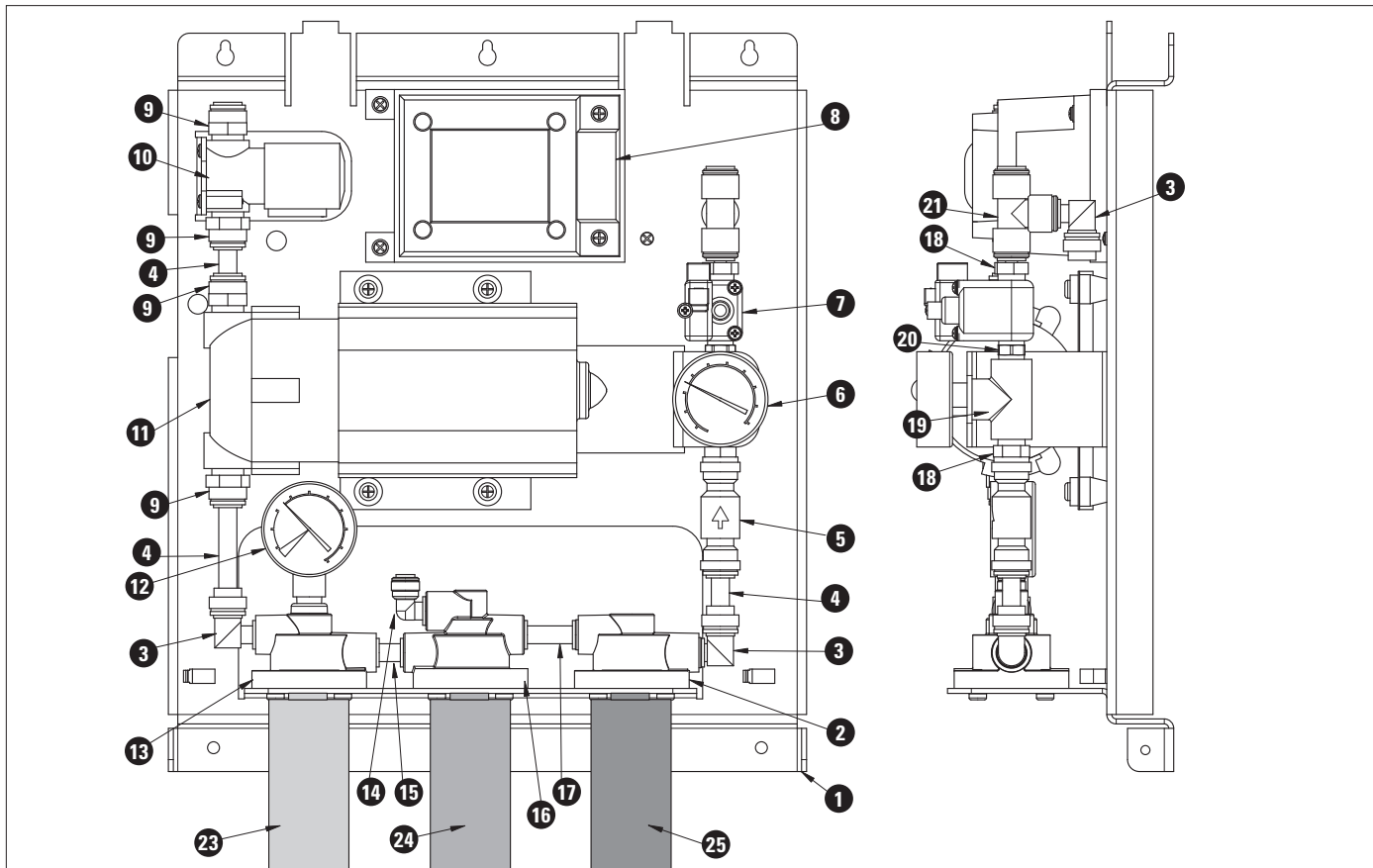

REPLACEMENT PARTS

KEY	PART NO.	DESCRIPTION	KEY	PART NO.	DESCRIPTION
1	EV312236	Plate, Mounting, MRS	14	EV312291	Elbow, Plug-in, 1/4 X 3/8 Stem
2	EV309646	Head, Lc, Qc/bw, NPT, .196	15	EV307587	Rigid Tube
3	EV310388	Plug In Elbow	16	EV311574	BW RO Head Sub Assy W/ Tabs
4	EV310326	Tubing, 3/8" PE	17	EV307613	Rigid Tube
5	EV310391	Check Valve	18	EV310313	Stem Adapter, 3/8"
6	EV311533	Pressure Gauge 1/4" Back Mount	19	EV310293	Tee, 1/4" threaded, PVC SCH.80
7	EV312271	Switch, Pressure, 1/4" FNPT	20	EV310305	Nipple, Hex, 1/4 NPT-M
8	EV312483	Transformer, 120 VAC - 24 VAC	21	EV310291	Tee, Union
9	EV308130	Male Connector, 3/8"NPT x 3/8"PI	Not Shown	EV312289	Cover (pictured on front page of manual)
10	EV311096	Valve, Solenoid, 24 VAC	Not Shown	EV312288	Wire Harness
11	EV312230	Pump, Booster, 24 VAC, 45 PSI	Not Shown	EV311145	Reject Flow Control - MRS-100
12	EV311409	Gauge Prs 2" 1/8"Im 125 psi SS	Not Shown	EV310362	Reject Flow Control - MRS-225
13	EV312299	Head, LC, BW, 3/8 JG & 1/8 NPT			

REPLACEMENT CARTRIDGES

KEY	PART NO.	DESCRIPTION	KEY	PART NO.	DESCRIPTION
N/A	EV9109-08	P5 Pre-Filter (not pictured here)	24	EV9627-11	MR-100 Cartridge
23	EV9607-41	6T0-BW Cartridge	24	EV9627-03	MR-225 Cartridge
			25	EV9627-05	7CC-BW Cartridge



For sales, replacement components, and service, contact your Everpure dealer or:

Everpure, LLC: 1040 Muirfield Drive • Hanover Park, Illinois 60133 • 800.323.7873

Everpure Europe NV: Toekomstlaan 30 • B-2200 Herentals, Belgium • Ph. +32 14 28 35 00, Fx. +32 14 28 35 05

Everpure Japan, Inc.: Hashimoto MN Bldg. 7F • 3-25-1 Hashimoto Sagamihara-S, Kanagawa 229-1103, Japan

Tel. 81-(0)42-7765-3011, Fax. 81-(0)42-775-3015

Technical Service

800.942.1153

www.everpure.com