

SPEC # _____

QUANTITY _____

APPLICATION

ICE



AT A GLANCE

Aqua-Pure[®] Models ICE190-S and ICE195-S single-cartridge water filtration systems assure consistent high-quality water for commercial cubers and flakers by reducing the harmful effects of sediment, chlorine, and scale at flow rates to 5.0 gpm (18.9 lpm). Built-in scale inhibition reduces the ability of calcium and magnesium to precipitate on the evaporator plates as hard scale.

- **ICE190-S** combines chlorine taste and odor reduction with cyst, bacteria and sediment reduction, and provides protection from the harmful effects of chlorine corrosion and scale for up to 54,000 gallons (204,412 liters).
- **ICE195-S** combines chlorine taste and odor reduction with sediment reduction for higher turbidity water and provides protection from the harmful effects of chlorine corrosion and scale for up to 54,000 gallons (204,412 liters).

PRODUCT BENEFITS

- Effectively reduces sediment and chlorine for equipment protection and clearer, great tasting ice.
- Revolutionary IMPACTechnology™ dual-zone media cartridge construction combines a membrane in series with premium activated carbon to provide unsurpassed throughput and cartridge life.
- Cartridge Life Warranted*.
- Certified by NSF to Standard 53 for cyst reduction (ICE190-S system).
- NSF Standard 42 and/or FDA CFR-21 compliance provides assurance of safety.
- The removal of over 99.99% of water-borne heterotrophic bacteria by membrane filtration as tested by CUNO (ICE190-S system).
- Built-in scale inhibitor reduces lime scale build-up on evaporator plates as tested by CUNO.
- SQC™ – Sanitary Quick Change – encapsulated cartridge design allows for fast and easy change-outs with a 1/4 turn while minimizing the possibility of leakage and contamination.
- 3/8" FNPT horizontal inlet and outlet ports allow direct or easily adaptable connections to existing plumbing lines.
- Exhausted cartridges may be incinerated for environmentally conscious disposal.

PRODUCT SPECIFICATIONS

Model Number	Part Number	Reduction Claims	Micron Rating	Capacity	Service Flow Rate	Application	Replacement Cartridge	Sizing
ICE190-S	56164-03	Cyst, Bacteria, Sediment, Chlorine Taste and Odor, Scale	0.2'	54,000 gallons (204,412 liters)	5.0 gpm (18.9 lpm)	Most Normal Water	HF90-S: 56135-05	Low Flow Cubers over 1,450 lbs (658 kg) High Flow Cubers over 1,000 lbs (454 kg) Flakers to over 2,400 lbs (1,089 kg)
ICE195-S	56164-04	Sediment, Chlorine Taste and Odor, Scale	3.0	54,000 gallons (204,412 liters)	5.0 gpm (18.9 lpm)	Higher Turbidity Water	HF95-S: 56135-09	Low Flow Cubers over 1,450 lbs (658 kg) High Flow Cubers over 1,000 lbs (454 kg) Flakers to over 2,400 lbs (1,089 kg)

* See Aqua-Pure Commercial Products Price Book for Terms and Conditions
† NSF Certified for Particulate, Class 1



a 3M company



Aqua-Pure® Commercial Products

SPEC # _____
QUANTITY _____
MODEL NUMBER _____
PART NUMBER _____

Aqua-Pure®
COMMERCIAL PRODUCTS
ICE190-S/ICE195-S

PHYSICAL SPECIFICATIONS

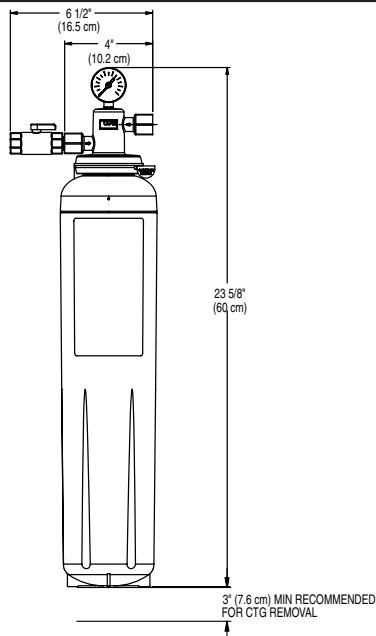

- System includes a head assembly with pressure gauge, inlet-water shutoff valve, mounting bracket, and single cartridge filter.
- Inlet and outlet plumbing connections are 3/8" FNPT.
- Filter cartridges are double o-ring seal type.
- System maximum operating temperature of 100°F (38°C).
- Recommended service flow rate is up to 5.0 gpm (18.9 lpm).
- Filter cartridges incorporate carbon block media protected by a pleated pre-filter membrane and a scale inhibitor.
- System is NSF Standard 42 and/or CFR-21 compliant.
- Cartridge body is constructed from high-impact glass-filled polypropylene.
- Cartridges are sanitary in design, requiring no contact with the filter media during cartridge change-out.
- Filter cartridges require no pre-activation.
- A NSF Performance Data Sheet (PDS) is included.
- Shipping weight: 5.8 lbs (2.6 kg)
- Operating weight: 11 lbs (5 kg)

Do not use with water that is microbiologically unsafe or of unknown quality without adequate disinfection before or after the system. Systems certified for cyst reduction may be used on disinfected water that may contain filterable cysts. EPA Establishment Number 070595-CT-001.

CUNO Incorporated recommends regularly scheduled maintenance and replacement of the filter cartridge(s) in order for the product to perform as advertised/sold. Change the filter cartridge at least every 6 months. CUNO shall not be liable for system failures due to improper maintenance.

INSTALLATION TIPS

- Shut off downstream equipment prior to installation of the system.
- Choose mounting location to support full system weight when operating.
- Do not exceed operating parameters for temperature or pressure.
- Do not install outdoors.
- For commercial use only with cold water.

LIMITED 5 YEAR WARRANTY

CUNO Incorporated warrants to the original purchaser-consumer that this product is free from defects in materials and workmanship. This warranty, together with any and all warranties implied by law, shall be limited to a period of five (5) years from the date of original purchase by the consumer. This warranty does not apply to failures that result from abuse, misuse, alteration or damage not caused by CUNO. This warranty is subject to exclusions and limitations. Please refer to the Warranty Card provided with the product for details.

SERVICE WORLDWIDE

CHINA

CUNO Filtration Shanghai Co. Ltd.
No. 2 Plant East Side
Xin Miao San Road
XinQiao Town SongJiang District
Shanghai, China 201612

JAPAN

CUNO K.K.
Hodogaya Station Building 6F
1-7, Iwai-Cho, Hodogaya-Ku
Yokohama 240-0023, Japan

AUSTRALIA

CUNO Pacific Pty Ltd.
140 Sunnyholt Road
Blacktown, N.S.W. 2148
Australia

BRAZIL

CUNO Latina Ltda
Rua AMF do Brazil - 251
18120 Mairinque-SP, Brazil

EUROPE

CUNO Limited
21 Woking Business Park
Albert Drive
Woking, Surrey
GU21 5JY, England

SINGAPORE

CUNO Filtration Asia Pte Ltd
2A Tuas Avenue 12
Singapore 639023



Visit www.nsf.org for the claims associated with products that are NSF listed.



CUNO Incorporated

400 Research Parkway
Meriden, CT 06450, USA
Toll Free: 1.888.218.CUNO
Worldwide: 203.237.5541
Fax: 203.238.8701

www.cunofoodservice.com