

UC100 Ultraviolet System Replacement Bulb/Handle Assembly

INSTALLATION INSTRUCTIONS

APPLICATION

The UC100 Ultraviolet System Replacement Bulb/Handle Assembly is for use with the UV100 Ultraviolet System. See Table 1 for your model.

INSTALLATION

When Installing this Product...

1. Read these instructions carefully. Failure to follow them could damage the product or cause a hazardous condition.
2. Check the rating given in the instructions and on the product to make sure the product is suitable for your application.
3. Removal and replacement of the ultraviolet lamps can easily be done by the homeowner following these instructions. The homeowner can also call an experienced service technician.
4. After installation is complete, check out product operation as provided in these instructions.



CAUTION

Personal Injury Hazard.

Power supply can cause electrical shock.

Disconnect power supply before replacing ultraviolet bulb(s).

Do not open base unit or lamp handle; there are no user-serviceable components inside.



WARNING

UV Light Hazard.

Harmful to bare skin and eyes.

Can cause temporary or permanent loss of vision.

Never look at bulbs while illuminated.

View illumination only through light indicator located on lamp handle.

To prevent exposure to ultraviolet light, disconnect power to Ultraviolet System before servicing any part of heating and air conditioning system.



CAUTION

UV Lamp Burn Hazard.

Harmful to bare skin.

Can cause severe burns.

Disconnect power and wait 15 minutes before removing ultraviolet bulb(s).



CAUTION

Breakable Glass Hazard.

Can cause personal injury.

Be careful when inserting bulb(s) into lamp base.

Wear protective gloves when handling bulb(s).





MERCURY NOTICE

This device contains mercury in the sealed ultraviolet bulb(s). Do not place your used bulb(s) in the trash. Dispose of properly.

Broken Bulb Cleanup.

Do not use a household vacuum.

Sweep debris (phosphor/glass) into a plastic bag and dispose of properly.

Contact your local waste management authority for instructions regarding recycling and the proper disposal of old bulb(s).

Replacing Your Bulbs

SmartLamp™ Models (UV100E1043, UV100E2009, and UV100E3007)

Replacement of your bulbs is required when LED on front of unit is lighted solidly.

NOTE: LED blinking slowly, one second on and one second off, indicates that ten percent or less of bulb life remains and homeowner must order new bulb(s).

IMPORTANT

Remember to press the reset button for five seconds after replacing the bulb(s).

UV100A1000, UV100A1018, UV100A1026, UV100A1059, UV100A2008, UV100E1001, UV100E1019, UV100E1027, UV100E1035 Models

Annual replacement of your bulbs is required.

To replace your bulbs:

1. Select and obtain the correct replacement bulb for your unit. See Table 1.
2. Disconnect the power to your heating and cooling system.
3. Unplug or turn off power to your UV System and allow the bulbs to cool for at least 15 minutes.
4. Rotate the lamp handle counterclockwise and gently pull the lamp handle to remove the bulb. See Fig. 1.

IMPORTANT

If the bulb in your model has external wires running along the glass surface, be sure to avoid pulling on those wires.

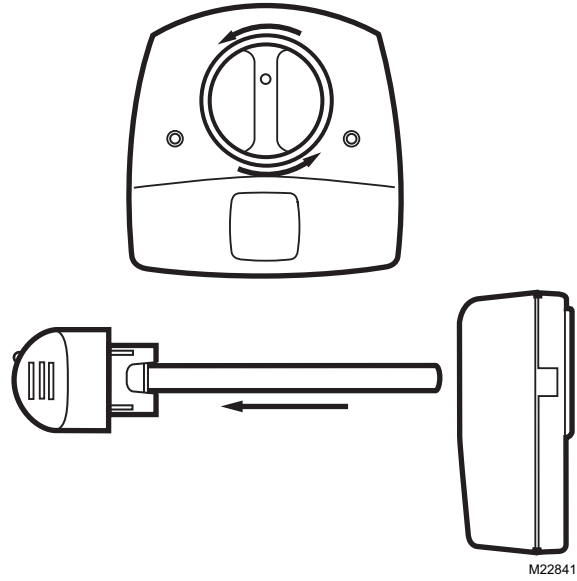

Fig. 1. Remove lamp bulb.

5. If you have a SnapLamp™ handle, follow steps 5 and 6; otherwise, proceed to step 7. Grasp the SnapLamp™ handle in one hand and the bulb glass in the other and pull straight apart. See Fig. 2.

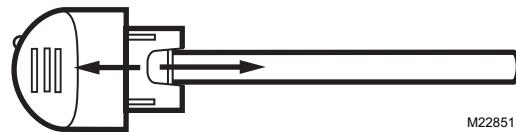

Fig. 2. Disconnect bulb from SnapLamp™ handle.

6. Insert the new bulb into the SnapLamp™ handle by aligning the notch and pushing straight together. See Fig. 3.

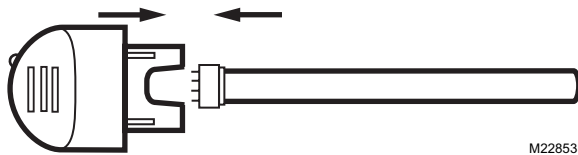

Fig. 3. Replace bulb in SnapLamp™ handle.

7. Insert the lamp handle into the base with the lamp light indicator at the eleven o'clock position. Continue pushing and gently rotating counterclockwise until the lamp inserts fully into the base. See Fig. 4.

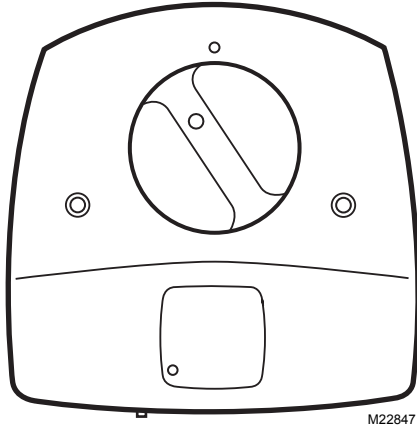

Fig. 4. Position lamp handle for insertion back into the lamp base.

8. Rotate the lamp handle clockwise until it snaps into place with the light indicator aligned with the raised button on the unit cover. See Fig. 5.

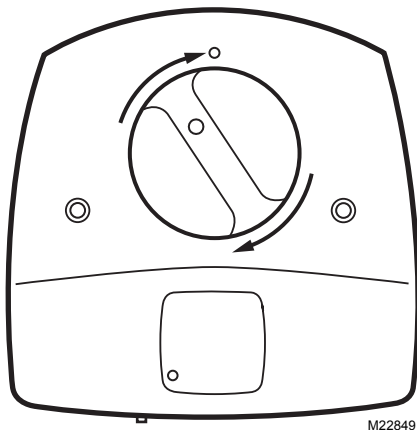

Fig. 5. Snap lamp handle into place.

9. Reconnect power to your UV System.
10. For UV Air Treatment System SmartLamp™ models, wait ten minutes for the airflow sensor to calibrate. During this time, the furnace fan must remain off.

NOTE: Failure to wait ten minutes for the airflow sensor to calibrate before powering the system fan causes the airflow sensor to incorrectly calibrate and the device to incorrectly function. If this occurs, remove power to the furnace or turn off the system fan, wait ten minutes, and then resume normal fan operation.



WARNING

UV Light Hazard.

Harmful to bare skin and eyes.

Can cause temporary or permanent loss of vision.

Never look at bulbs while illuminated.

View illumination only through light indicator located on lamp handle.

To prevent exposure to ultraviolet light, disconnect power to Ultraviolet System before servicing any part of heating and air conditioning system.

11. Verify that your ultraviolet bulbs are operating by viewing only through the lamp light indicator on the lamp handle. Never look directly at your lamp while it is illuminated.
12. Reconnect the power to your heating and cooling system.
13. For SmartLamp™ models, press and hold the reset button for five seconds to reset the internal timers.

Table 1. Replacing Your Bulb(s) and Handle Assembly.

Unit Description	Replacement Bulb/ Handle Assembly	SnapLamp™ Replacement Bulb	Wattage
UV100E1001 and UV100E1043 Air Treatment Systems	UC100E1006	UC18W	18W
UV100E1019 and UV100E2009 Air Treatment Systems (dual lamp)	UC100E1014 (twin pack)	UC36W (two bulbs required)	36W
UV100E1027 Surface Treatment System	UV100A1021	N/A	25W
UV100E1035 and UV100E3007 Surface Treatment Systems	UC100E1030	UC36W	36W
UV100A1000 Air Treatment System	UC100A1005	UC18W	18W
UV100A1018 Air Treatment System (dual lamp)	UC100A1013 (twin pack)	UC36W (two bulbs required)	36W
UV100A1026 Surface Treatment System	UC100A1021	N/A	25W
UV100A1059 Surface Treatment System	UC100A1054	UC36W	36W
UV100A2008 Surface Treatment System	UC100A1054	UC36W	36W

Automation and Control Solutions

Honeywell International Inc.
1985 Douglas Drive North
Golden Valley, MN 55422
customer.honeywell.com

Honeywell Limited-Honeywell Limitée
35 Dynamic Drive
Scarborough, Ontario M1V 4Z9

© U.S. Registered Trademark
© 2005 Honeywell International
69-1444-4 G.H. Rev. 04-05



Printed in U.S.A. on recycled
paper containing at least 10%
post-consumer paper fibers.

Honeywell