



22,000-25,000 BTU/HR Heater For:

- *Garages / Workshops*
- *Barns / Utility Buildings / Storage Sheds*
- *Animal Pens / Stalls*
- *Loading Docks*
- *Building Construction Sites*
- *Doorways / Ramps For Snow Prevention*



40,000 BTU/HR Heater For:

- *Loading Docks*
- *Warehouses*
- *Factory Production / Assembly Areas*
- *Pole Barns, Farm Buildings*
- *Animal Comfort (pens, animal stalls, etc.)*
- *Auto & Truck Repair Shops*
- *Sporting Arenas*
- *Public Entranceways*

America's Most Complete Line Of Infrared Heaters!

HIGHLY EFFICIENT AND COST EFFECTIVE RADIANT HEAT.

- **Efficient Infrared Heat**- Directly heats people and objects which in turn heats surrounding air to desired temperature
- **Economical** - No electricity required
- **Instant Heat** - Includes adjustable thermostat for individually controlled warmth
- **Heating Area** - MH25: Up to 600 sq. ft.
MH40: Up to 850 sq. ft.
- **Quiet, Clean, Odor-Free Operation** - Propane or natural gas
- **Maintenance Free** - No moving parts to service
- **Includes Wall Louver For Fresh Air Intake**
- **CSA Certified**
- **Limited 1-Year Warranty** - On gas control
- **Pro-Rated 5-Year Warranty** - On burner assembly

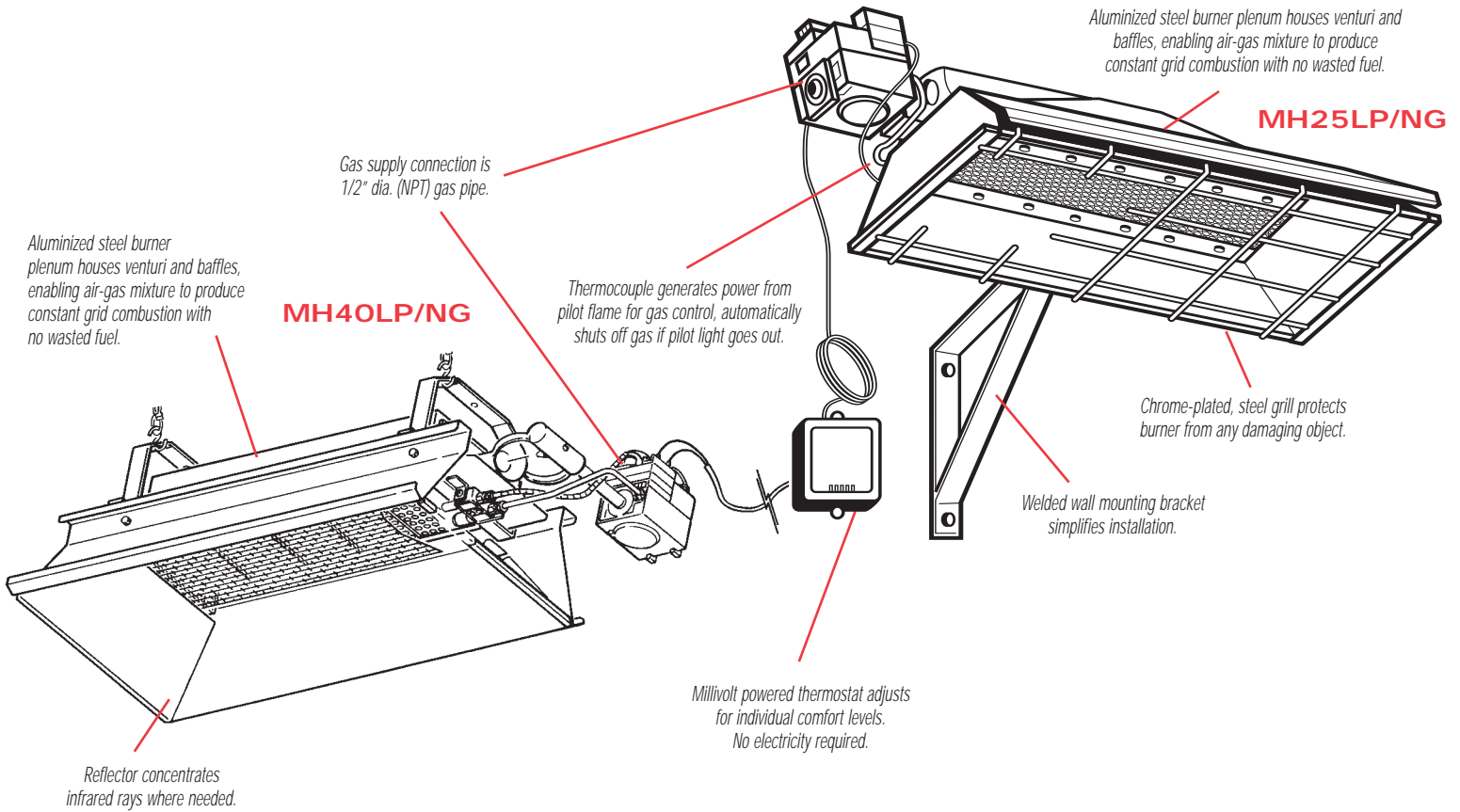

SPECIFICATIONS & TECHNICAL DATA

MODEL NUMBER	BTU/HR	MOUNTING CLEARANCE TO COMBUSTIBLES				TOTAL DIMENSIONS L x W x H (INCHES)	SHIPPING WEIGHT (LBS)	TYPICAL MOUNTING HEIGHT	GAS INLET	MANIFOLD PRESSURE
		TOP	SIDES	BACK	BELOW					
MH25LP Stock Number: F272100	22,000*	14"	16"	12"	48"	29 3/4 x 12 1/4 x 7	25	7'-9"	1/2"	10"
MH25NG Stock Number: F272200	25,000*	14"	16"	12"	48"	29 3/4 x 12 1/4 x 7	25	7'-9"	1/2"	6"
MH40LP Stock Number: F272700	40,000*	34"	30"	30"	68"	30 1/4 x 19 1/4 x 12	25	10'-12'	1/2"	10"
MH40NG Stock Number: F272800	40,000*	34"	30"	30"	68"	30 1/4 x 19 1/4 x 12	25	10'-12'	1/2"	5.8"

* Ratings shown are for elevations up to 2,000 feet. (In Canada, refer to rating tag.) For elevations above 2,000 feet, ratings should be reduced at the rate of 4% for each 1,000 feet above sea level or as specified by local authority having jurisdiction.

DO NOT use heater in sleeping quarters, mobile homes, or recreational vehicles.



CSA Certified