

# Freedom Advantage

## Programmable Single or Multi-Stage Digital Thermostat

### Standard Features:

- ☑ Selectable 7-day, 5-2, or 5-1-1 programmability
- ☑ Selectable auto-changeover or manual modes
- ☑ Remote sensing capability
- ☑ Adjustable limits, differentials, and independent heat/cool cycle rates
- ☑ ServiceWatch® monitoring (filter, heating & cooling)
- ☑ Advanced Performance Technology (to adjust temperature recovery times for maximum efficiency)
- ☑ Multiple lockout levels with password protection

### Optional Features:

- ☐ Black case (FP800-B model only)
- ☐ Programmable fan (FP810C model only)

### Applications:

**Equipment:** single or two-stage conventional heating and/or cooling or single or multi-stage heat pump systems with electric or dual fuel auxiliary heat.

**Building Types:** residential/light commercial (single homes, townhomes, condos, apartments, etc.)

**Installation Considerations:** For installation on any interior wall surface. Thermostat should be located approximately 5 feet above the floor in an area with good air circulation (unless remote sensing option is used).

### Specifications:

Input voltage:	24 VAC ±10% 50/60 Hz <i>(not for use with millivolt systems)</i>
Output Drive:	1.0 amps max per circuit
Comfort temperature range:	40°F to 90°F
Programming Modes:	7-day, 5-2, or 5-1-1
Accuracy:	±1°F
Display:	LCD with blue/green backlight; 0.6" characters
Case material:	White or black plastic, flame retardant
Tamper resistant:	Multiple lockout levels
Wire connections:	Screw Terminal
Power:	Battery (optional common wire connection)
Dimensions:	4"H x 6"W x 1.5"D

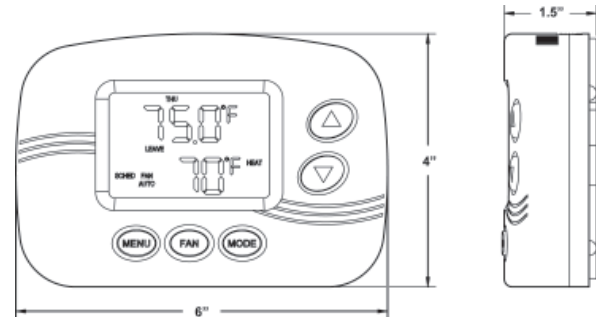

### Review Stamp:



1225 Tunnel Rd. - Perkasi, PA 18944-2118  
Toll Free 800-782-8412 - Main Phone 215-257-3621 - Fax 215-257-4288  
Website [www.psgcontrols.com](http://www.psgcontrols.com) - Email [sales@psgcontrols.com](mailto:sales@psgcontrols.com)

## Descriptive Specification:

The HVAC temperature control shall have a digital LCD showing setpoint and also alternating between current room temperature, time, and mode. The control shall be programmable using a schedule of either 7-day, 5-2, or 5-1-1. Multiple user lockout levels shall be available through the programming menu. Lockout levels shall include: (1) no password protection, (2) advanced settings protected, (3) schedule protected. Configuration lockout shall also be available (in the configuration mode only). In the event schedule mode, control shall utilize Advanced Performance Technology (AdPt), allowing the HVAC system to gradually change the temperature from the energy saving setback temperature to the comfort temperature. Using AdPt, the control shall activate either heating or cooling at the appropriate time to reach the desired temperature by the correct time. Control shall have "ServiceWatch®" capabilities, displaying when filter, heating and cooling systems need to be checked. Run times of the system (configurable) shall be monitored. Control shall have the ability to operate with a remote sensor, either outdoor, floor slab, or wall-mounted. Control shall also have a variety of configurable settings, including (but not limited to) heating and cooling limits and independent heating and cooling cycle rates and differentials. The FP810C model shall have programmable fan settings, conforming to Title 24 regulations in the state of California.

## Wiring:

Model shown: FP800

Notes:

- Freedom Advantage control includes a wiring terminal block. All wiring is the responsibility of the installer.
- The wiring diagrams shown are only typical. Detailed wiring diagrams will be outlined in the instruction sheets.

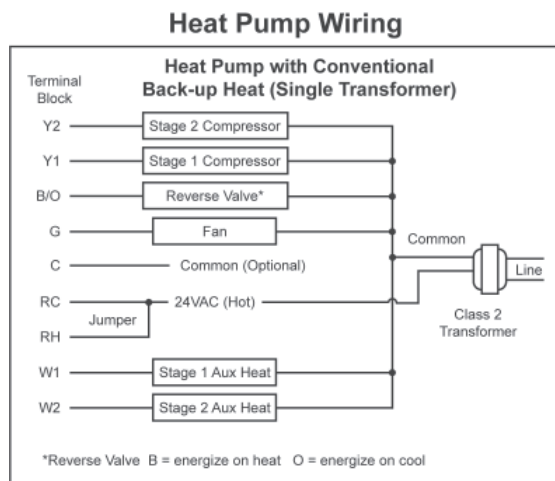

## Conventional System Wiring

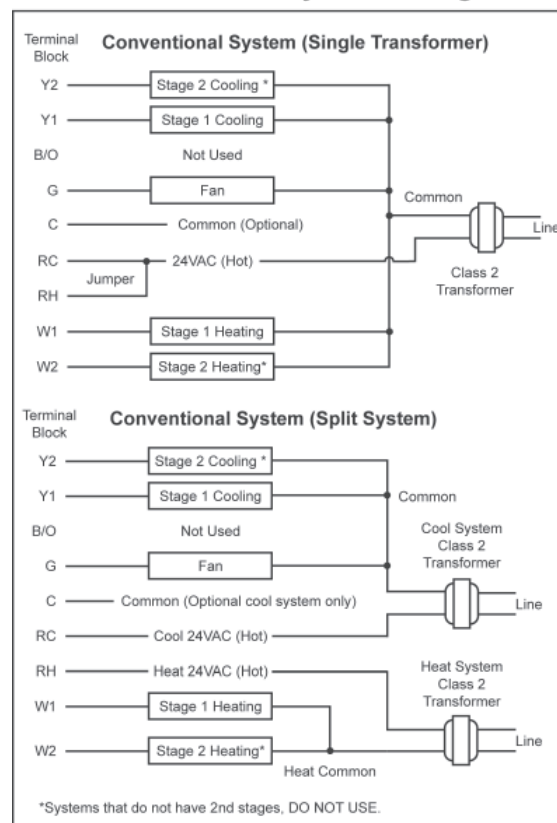

## Model Selection:

Model #	Comments	Stages/System
<input type="checkbox"/> FP800		All models are configurable - single or multi stage heating and/or cooling (Please contact PSG for a list of recommended applications.)
<input type="checkbox"/> FP800-B	Black case	
<input type="checkbox"/> FP810C	Programmable fan	

## Accessories:

- FP-OS --- Remote Sensor (outdoor or floor slab)       FP-WS --- Remote Sensor (wall mount)

## Warranty:

Freedom Advantage thermostats have a 5 year or 2 year limited warranty, depending on model, that protects against defects in workmanship and materials. (Contact PSG for full detailed warranty policy.)