

# Specification Data

## Panasonic Ventilation Fan



### Description

Ventilating fan shall be 2-speed Low Noise ceiling mount type rated for continuous run. Fan shall be Energy Star rated and certified by the Home Ventilating Institute (HVI). Evaluated by Underwriters Laboratories and conform to both UL and CSA safety standards.

## FV-11VQD2 (60 cfm)

### 2-Speed

#### Motor/Blower:

- Four-pole totally enclosed condenser motor rated for continuous run.
- Power Rating shall be 120 volts and 60 hz
- Fan shall be UL listed for tub/shower enclosure when used with a GFCI branch circuit wiring.
- Motor equipped with thermal-cutoff fuse.
- Removable with permanently lubricated plug-in motor.

#### Housing:

- Rust proof paint, galvanized steel body.
- Detachable 4" diameter duct adapter.
- Built in backdraft damper.
- Expandable extension brackets up to 26".

#### Grille:

- Attractive design using ABS material.
- Attaches directly to housing with torsion springs.

#### Switch:

- 3 position switch included. Off-Low-High

**Warranty:** The factory warranty shall be a minimum of 3 years limited warranty on parts.

#### Typical Specifications:

Ventilating fan shall be of the 2-speed High/Low ceiling mount, Energy Star rated type, with no less than 110/60 CFM and no more than 1.5/0.3 sone as certified by the Home Ventilating Institute (HVI) at 0.1 static pressure in inches water gauge. Power consumption shall be no greater than 27/19 watts and Energy Star rated with efficiency rating of no less than 4.1/3.2 cfm/watt. The motor shall be totally enclosed, four pole condenser type engineered to run continuously. Power rating shall be 120v/60Hz. Duct diameter shall be no less than 4". Fan shall be UL listed for tub/shower enclosure when used with GFCI branch circuit wiring.

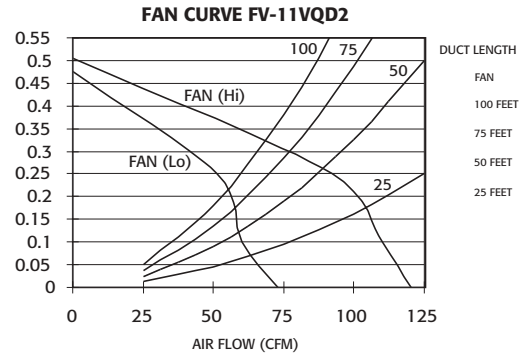
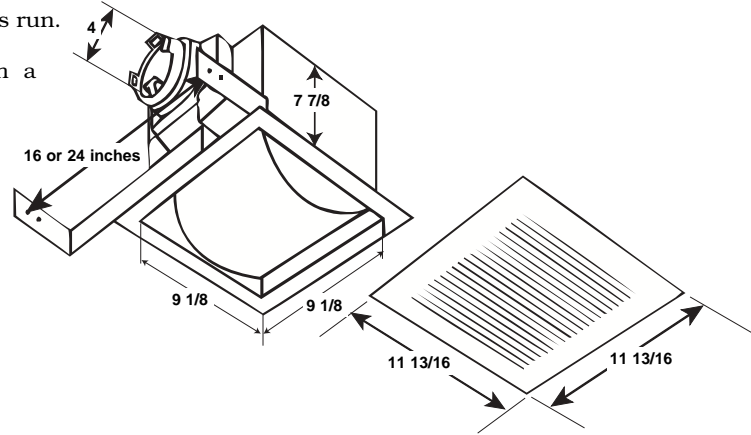

#### Specifications:

	FV-11VQD2			
	High		Low	
Fan Speed				
Static Pressure in inches w.g.	0.1"	0.25"	0.1"	0.25"
Air Volume (CFM)	110	92	60	51
Noise (sones)	1.5	NA	<0.3	NA
Power Consumption (watts)	27	25	19	17
Energy Efficiency: CFM's / Watt	4.1	3.6	3.2	3.0
Speed (RPM)	1022	1235	803	1095
Energy Star Rated	Yes		Yes	
Washington State VIAQ Code	Yes		Yes	

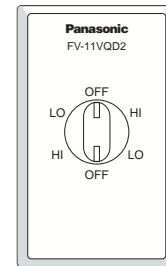

3 position switch included.



For Complete Installation Instructions Visit [www.panasonic.com/building](http://www.panasonic.com/building)

Model	Quantity	Comments	Project:
			Location:
			Architect:
			Engineer:
			Contractor:
			Submitted by:
			Date: