

## INSTALLATION INSTRUCTIONS

### Ventilating Fan

Model No. FV-08VQC5 FV-11VQC5

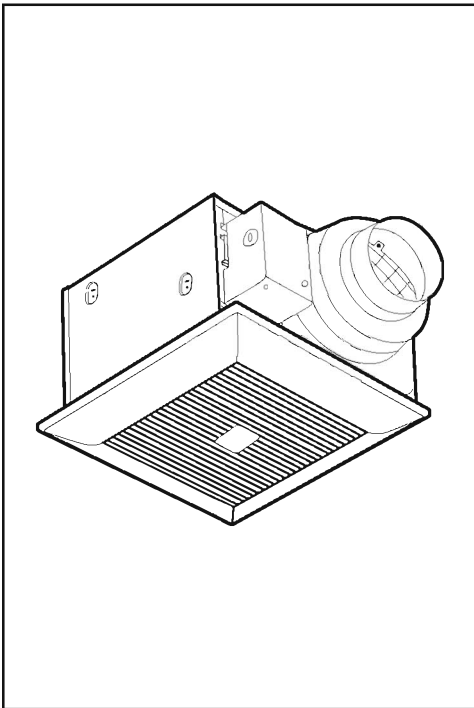

#### Contents

General Safety Information .....	2
Description .....	3
Unpacking .....	3
Supplied Accessories .....	3
Dimensions .....	4
Wiring Diagram .....	4
Switch Indication .....	5
Operation .....	5
Installation I (Joist Mounting - I) .....	6-8
Installation II (Centered/Suspension Bracket Mounting) ..	9
Installation III (Joist Mounting - II) .....	10
Maintenance (Cleaning) .....	10
Practical Guide To Installation .....	11
Specifications .....	11
Product Service .....	11

#### READ AND SAVE THESE INSTRUCTIONS

Thank you very much for having purchased our Ventilating Fan.

Please read these instructions carefully before attempting to install, operate or service the Panasonic Ventilating Fan. Failure to comply with instructions could result in personal injury and/or property damage. Please retain this booklet for future reference.

# GENERAL SAFETY INFORMATION

## WARNING:

To reduce the risk of fire, electric shock or injury to persons, observe the following:

1. Use this unit only in the manner intended by the manufacturer. If you have any questions, contact to the manufacturer.
2. Before servicing or cleaning unit, switch power off at service panel and lock the service disconnecting means to prevent power from being switched on accidentally. When the service disconnecting means cannot be locked, securely fasten a prominent warning device, such as a tag, to the service panel.
3. Installation work and electrical wiring must be done by qualified person(s) in accordance with all applicable codes and standards, including fire-rated construction.
4. Sufficient air is needed for proper combustion and exhausting of gases through the flue (chimney) of fuel burning equipment to prevent back drafting. Follow the heating equipment manufacturer's guideline and safety standards such as those published by the National Fire Protection Association (NFPA), and the American Society of Heating, Refrigeration, and Air Conditioning Engineers (ASHRAE) and the local code authorities.
5. When cutting or drilling into wall or ceiling, do not damage electrical wiring and other hidden utilities.
6. Ducted fans must always be vented to the outdoors.
7. If this unit is to be installed over a tub or shower, it must be marked as appropriate for the application and be connected to a GFCI (Ground Fault Circuit Interrupter)-protected branch circuit.
8. These models are UL listed for tub and shower enclosures.
9. Not to be installed in a ceiling thermally insulated to a value greater than R40.(This is required for installation in Canada only)
10. Do not use this fan with any solid-state speed control device. Solid state controls may cause harmonic distortion which can cause motor humming noise.

1. Do not install this ventilating fan where interior room temperature may exceed 104°F (40°C).
2. Make sure that the electric service supply voltage is AC 120V, 60Hz.
3. Follow all local electrical and safety codes, as well as the National Electrical Code (NEC) and the Occupation Safety and Health Act (OSHA).
4. Always disconnect the power source before working on or near the fan, motor, light fixture or junction box.
5. Protect the power cord from sharp edges, oil, grease, hot surfaces, chemicals or other objects.
6. Do not kink the power cord.
7. Do not install the unit where ducts are configured as shown in Fig. A.
8. Provide make up air for proper ventilation.
9. A statement to the effect that when the product is to no longer be used, it must not be left in place but removed, to prevent it from possibly falling.
10. Do not disassemble the unit for reconstruction. It may cause fire or electric shock.
11. Ceiling joist must be subjected to static load more than five times the weight of the product.
12. Do not install with a method which is not approved in the instructions.



Fig. A

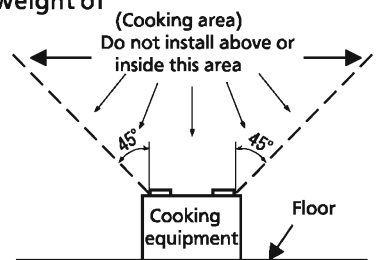

Fig. B

## CAUTION:

1. For general ventilating use only. Do not use to exhaust hazardous or explosive materials and vapors.
2. Not for use in cooking area. (Fig.B)
3. This product must be properly grounded.

## DESCRIPTION

These Panasonic ventilating fan models are listed by UL under UL file No. E78414.

These Panasonic ventilating fan models use a sirocco fan driven by a capacitor motor.

The motor is designed to have an extended service life with reduced energy consumption.

It also incorporates a thermal-cutoff for safety. The grille covering the fan body is a spring-loaded, quick remove type. A damper for preventing air counterflow is provided. The blower uses a high-capacity sirocco fan developed to reduce the noise level.





These Panasonic ventilating fan models are equipped with a motion sensor and a humidity sensor that turn on automatically when motion is detected, when humidity increases rapidly, or when humidity rises above a 30% ~ 80% relative humidity set-point. It is user-adjustable to operate 0.5 ~ 60 minutes after the sensors are no longer detected.



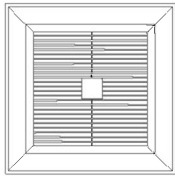

## UNPACKING

Unpack and carefully remove the unit from carton.

Refer to the supplied accessories list to verify that all parts are present.

## SUPPLIED ACCESSORIES

Part name	Appearance	Quantity
Grille		1
Suspension bracket I		1
Suspension bracket II		1
Suspension bracket III		1
Suspension bracket IV		1

Part name	Appearance	Quantity
Screw I (ST4.2X6)		2
Screw II (ST4.2X14)		1
Long screw (ST4.2X20)		6
Installation instructions		2
Warranty sheet		1

### CAUTION:

The special-purpose or dedicated parts, such as mounting fixtures, must be used if such parts are provided.

# DIMENSIONS

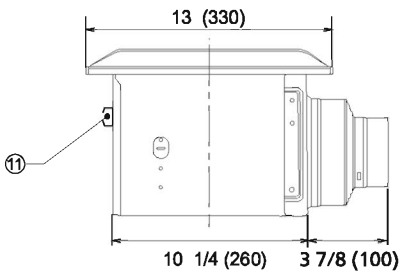
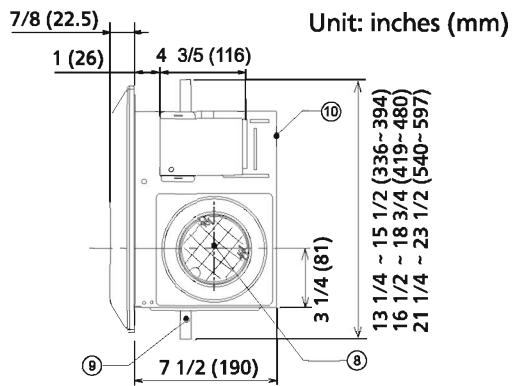
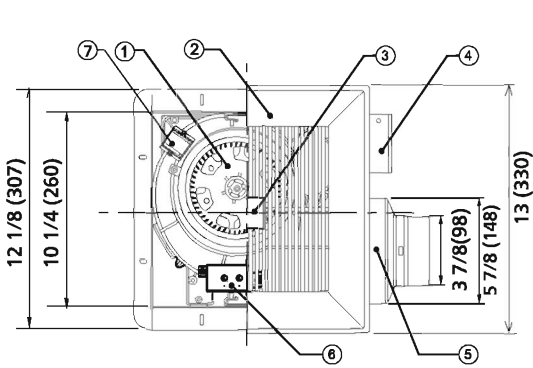

No.	Part name
1	Blade
2	Grille
3	Motion sensor unit
4	Junction box
5	Adaptor
6	Switch unit
7	Humidity sensor unit
8	Damper
9	Suspension bracket
10	Fan body
11	Bracket cover

# WIRING DIAGRAM

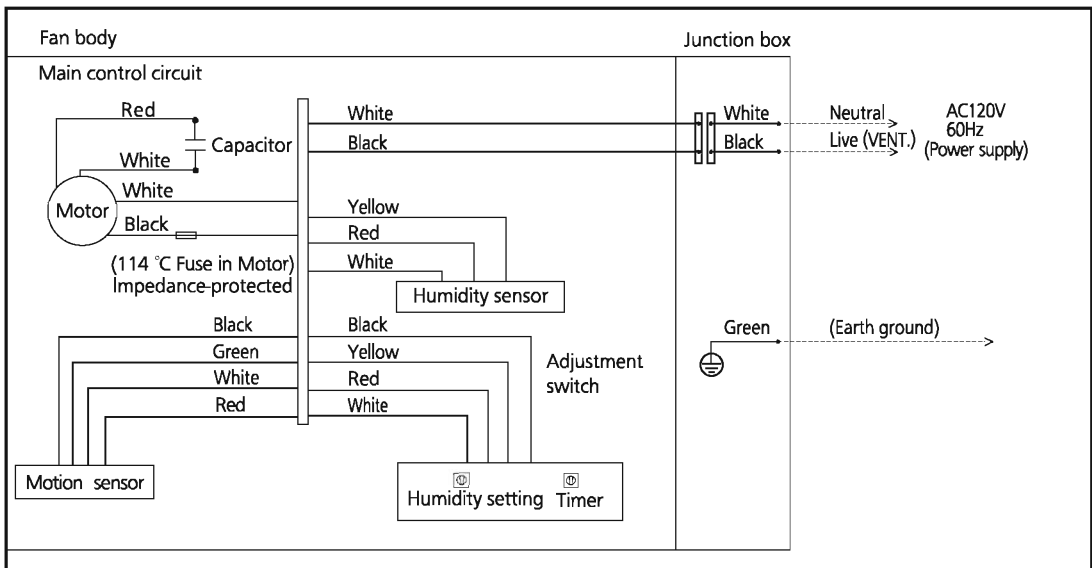

# SWITCH INDICATION

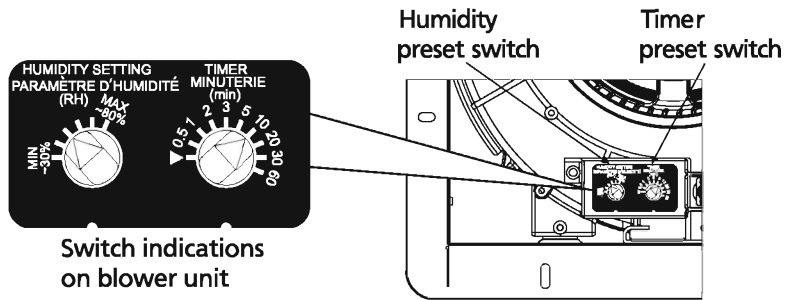

Switch indications on blower unit

Humidity preset switch positions (Tolerance:  $\pm 10\%$ )

MIN ~MAX	~30%	~40%	~50%	~60%	~70%	~80%
----------	------	------	------	------	------	------

Factory setting: ~50% RH ("~" means "about")

Timer preset switch positions

Timer [min]	▶	0.5	1	2	3	5	10	20	30	60
-------------	---	-----	---	---	---	---	----	----	----	----

Factory setting : 10 minutes.

Position "▶" : refer to 0.5 minute

## OPERATION

- Panasonic ventilating fan responds to:
  - (1) Motion sensor detectable condition.
  - (2) Humidity sensor detectable condition.

- Motion sensor detectable condition
  - The delay time is determined by timer preset switch.
  - The unit continues running for an adjustable duration of 0.5 to 60 minutes, after motion is no longer detected.

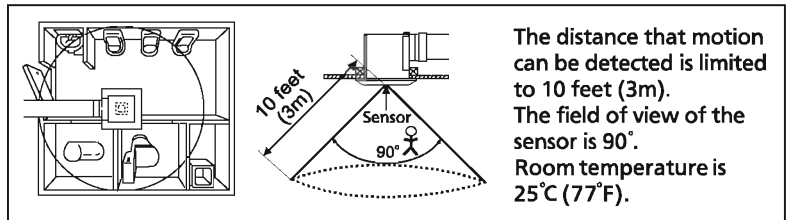

Human activity	INSIDE		OUTSIDE
Fan activity	Stop	When motion is detected, fan runs	Remains running until the delay time has passed

- Humidity sensor detectable condition
  - (a) rapid to moderate humidity increases and (b) humidity above a 30%~80% relative humidity set-point. (a) and (b) are set with "HUMIDITY SETTING" adjustment. Fan may occasionally turn on when environmental conditions change. The "TIMER" controls how long the fan remains on (a) after rise in humidity and (b) humidity level is below the set-point decreasing about 5%RH.

### CAUTION:

1. If this unit is to be install over a tub or shower, for best results, locate it near the shower head.
2. Long-time operation will influence the detecting precision as dust accumulates. Humidity preset switch may need to be adjusted.

# INSTALLATION I (JOIST MOUNTING - I)

## Joist situation:

Spacing A is 16 inches (406 mm) to 24 inches (609 mm) on center joists

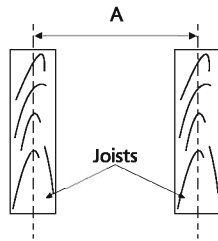

1. If the spacing A is 16 inches (406 mm) to 24 inches (609 mm) on center joists, please follow the installation step as below.

## IMPORTANT:

Remove the tape from damper and adaptor before installation. As shown below:

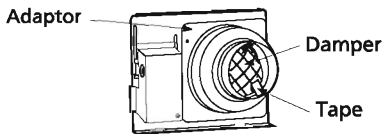

2. Insert the suspension bracket I and II into the fan body. (Select the suspension bracket connection holes as shown below) (Fig.1)

## Suspension bracket connect method:

Suspension bracket I and II connect with screw I as shown below:

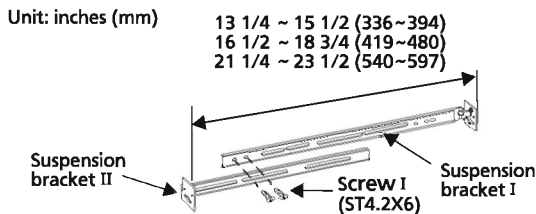

3. Install the suspension bracket and the flange of fan body to joists by using long screws (ST4.2X20) and secure it to the fan body by using screw II (ST4.2X14). (Fig.2)

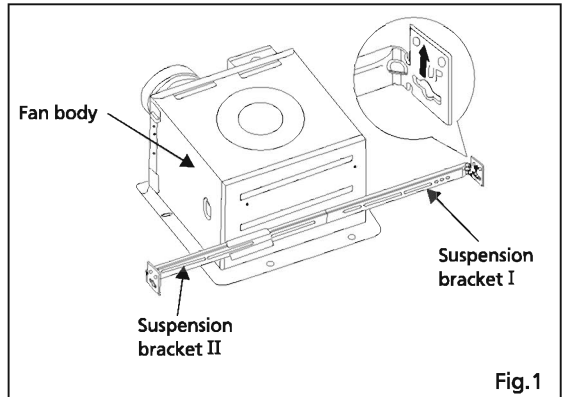

Fig.1

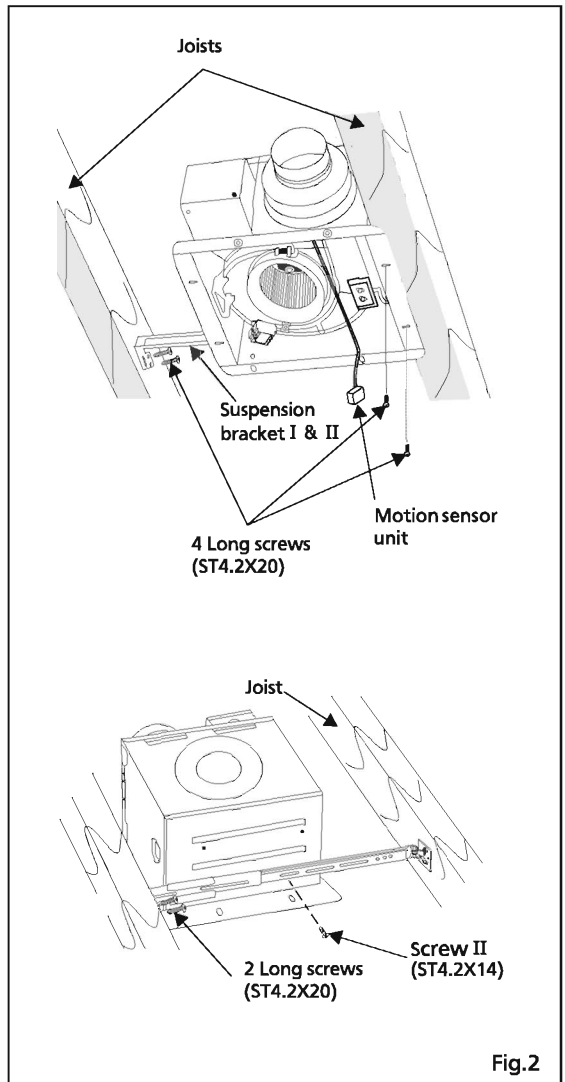
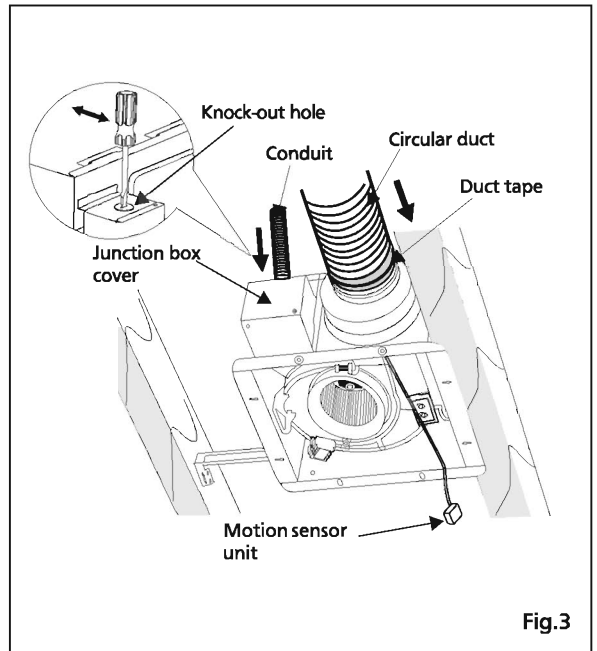

Fig.2

## INSTALLATION I (JOIST MOUNTING - I) CONTINUED

4. Install a circular duct and secure it with clamps, or wire ties and seal it with mastic or approved duct tape. 4 inch circular duct or 6 inch circular duct is needed to connect to relevant part of common adaptor. (Fig.3)

5. Remove junction box cover and secure conduit or stress relief to junction box knock-out hole. (Fig.3)



6. Refer to wiring diagram below.  
Follow all the local electrical safety codes as well as the National Electrical Code (NEC).  
Using UL approved wire nuts, connect house power wires to ventilating fan wires. (Fig.4)

**CAUTION:**  
Mount junction box cover carefully so that lead wires are not pinched.

**Note:**  
Wiring detail please refer to the wiring diagram on page 4.

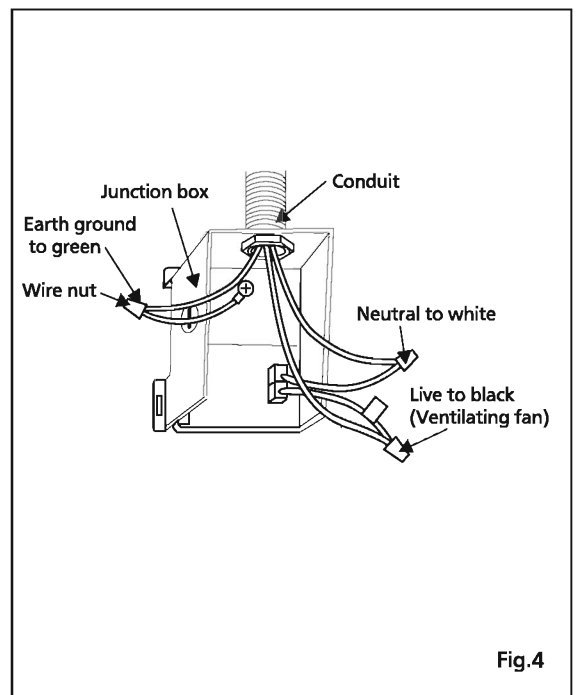

# INSTALLATION I (JOIST MOUNTING - I) CONTINUED

7. Finish ceiling work. Ceiling hole should be aligned with the inside edges of the flange. (Fig.5)

**IMPORTANT:**

Remove the tapes from louver and springs before installation. As shown below:

Tapes

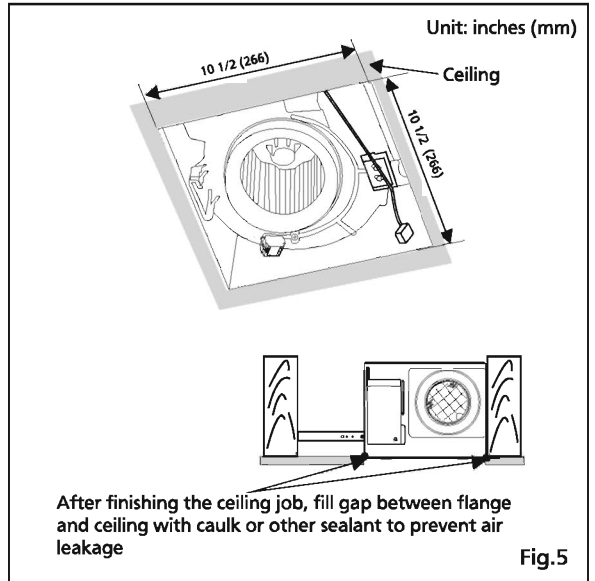
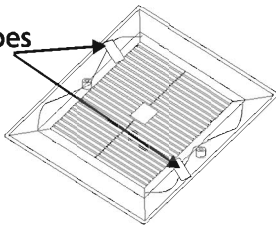

8. Insert the sensor unit into slot of the grille; fix the lead wire of sensor unit into the clasps (3 position) (Fig.6).

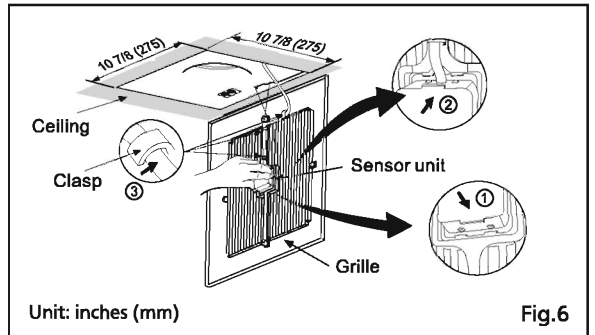

9. Adjust timer preset switch and humidity preset switch (Fig.7). Refer to switch indication on page 5.

**CAUTION:**

Mount grille carefully so that lead wire of sensor unit is not pinched.

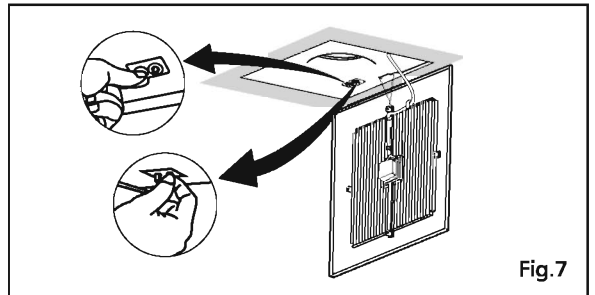

10. Insert the mounting springs into the slot as shown and mount grille to fan body. (Fig.8)

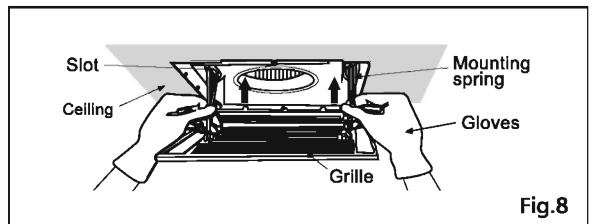

# INSTALLATION II (CENTERED/SUSPENSION BRACKET MOUNTING)

## Joist situation:

Spacing A is 16 inches (406 mm) to 24 inches (609 mm) on center joists

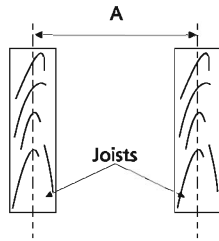

1. If the spacing A is 16 inches (406 mm) to 24 inches (609 mm) on center joists, please follow the installation step as below.
2. Insert the suspension bracket I and II into the fan body and suspension bracket III or IV into the adaptor. (Select the suspension bracket connection holes as shown below) (Fig.9, Fig.10)

## Suspension bracket connect method:

Suspension bracket I and II connect with screw I as shown below:

Unit: inches (mm)

13 1/4 ~ 15 1/2 (336~394)  
16 1/2 ~ 18 3/4 (419~480)  
21 1/4 ~ 23 1/2 (540~597)

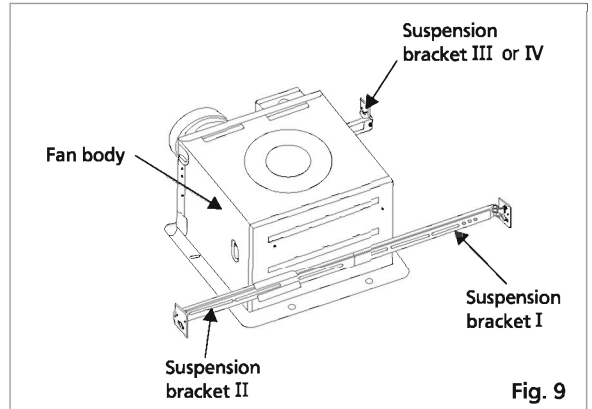
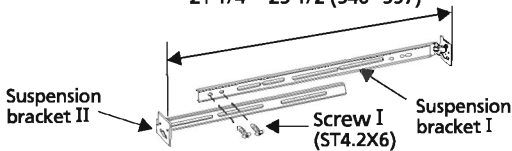

Fig. 9

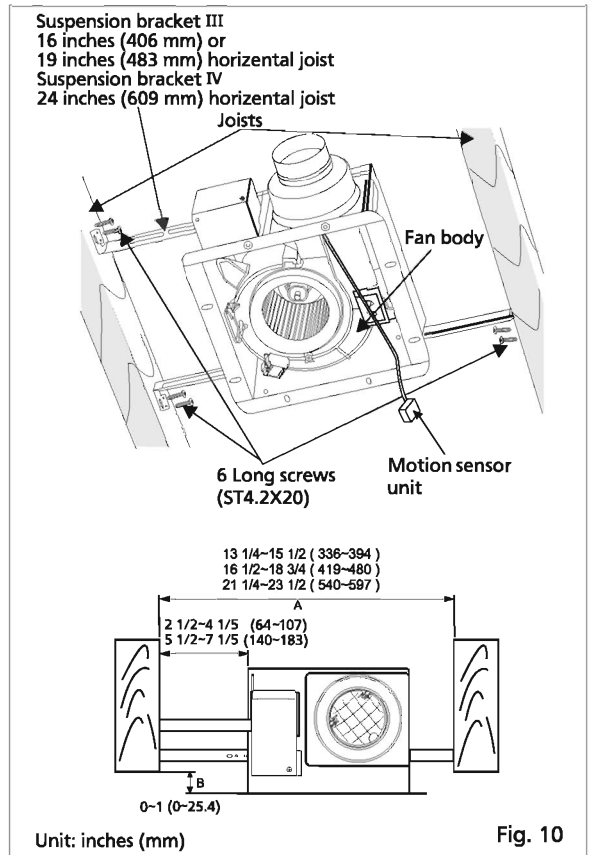

Fig. 10

3. Install the suspension bracket to joists by using long screws (ST4.2X20) (Fig.10) and secure it to the fan body by using screw II (ST4.2X14). (Fig.11)
4. Follow steps 4 to 10 of installation I (page 8 and page 9) to complete the installation work.

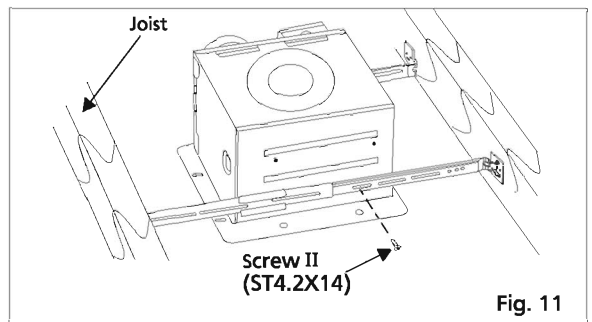
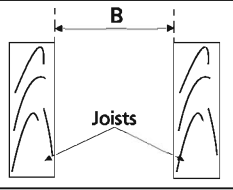

Fig. 11

## INSTALLATION III (JOIST MOUNTING - II)

### Joist situation:

Spacing B is  
10 1/2 inches (266 mm) to  
11 1/2 inches (292 mm)  
on joists



1. If the spacing B is 10 1/2 inches (266 mm) to 11 1/2 inches (292 mm) on joists, please follow the installation step as below.
2. Secure 4 long screws (ST 4.2X20) at flange of frame. (Fig.12)
3. Follow steps 4 to 10 of installation I (page 8 and page 9) to complete the installation work.

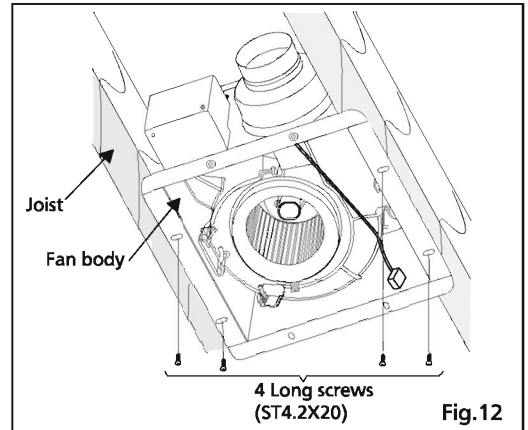

## MAINTENANCE (CLEANING)

### WARNING:

Disconnect power source before working on unit. Routine maintenance must be done every year.

### CAUTION:

1. Never use gasoline, benzene, thinner or any other such chemicals for cleaning the ventilating fan.
2. Do not immerse motor in water when cleaning.
3. Do not soak resin parts in water over 140°F (60°C).
4. Do not use cleaning sprays, solvents, or water on or near the sensors.

1. Remove grille by pulling down the mounting spring opposite the sensor lead. Remove sensor unit then pull down the other mounting spring. (Squeeze mounting spring and pull down carefully). (Fig.13, Fig.14)
2. Clean grille. (Don't put into hot water. Use non-abrasive kitchen detergent, wipe dry with clean cloth) (Fig. 15)
3. The grille should be dry after cleaning.
4. Remove dust and dirt from fan body using a vacuum cleaner. (Fig. 16)
5. Using a cloth dampened with kitchen detergent, remove any dirt from fan body. Wipe dry with clean cloth. (Fig. 17)
6. Replace grille.

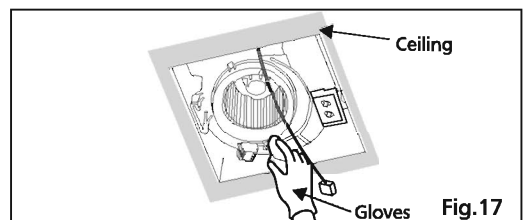
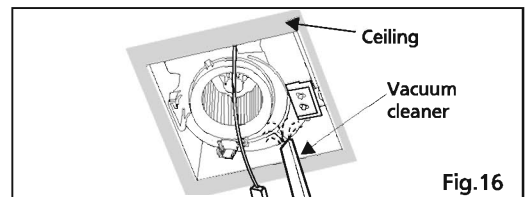
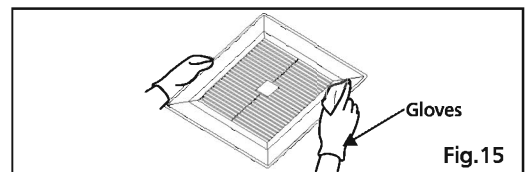
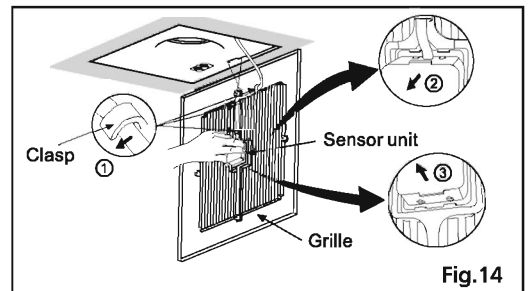
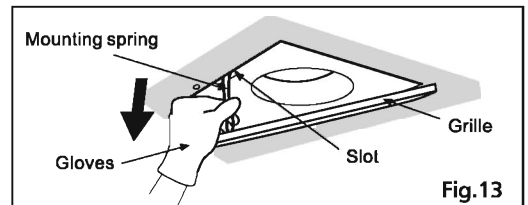

## PRACTICAL GUIDE TO INSTALLATION

Properly insulate the area around the fan to minimize building heat loss and gain. (Fig.18)

Loose fill or batt insulation can be placed directly over the fan housing in the attic. Panasonic fans and fan/light combination units do not create excessive heat that is a common problem with recessed light fixtures or some competitors' fan/light combinations. Our efficient, cool-running motors and our fluorescent lamp do not create enough ambient heat to be subjected to these limitations.

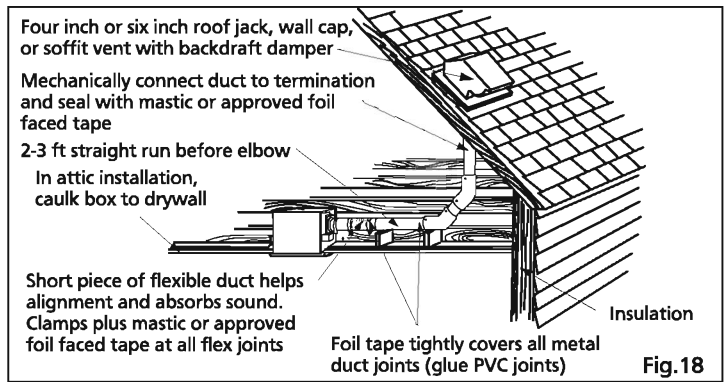

## SPECIFICATIONS

### ■ Specifications

Model No.	Air direction	Voltage (V)	Frequency (Hz)	Duct diameter (inches)	Noise (sones)	Power consumption (W)	Speed (rpm)	Air volume at 0.1"WG (CFM)	Weight lb.( kg)
FV-08VQC5	Exhaust	120	60	4 or 6	<0.3	15.5	815	80	10.6(4.8)
FV-11VQC5	Exhaust	120	60	4 or 6	0.3	23.0	960	110	10.6(4.8)

HVI Certified performance based on HVI Procedures 915,916,and 920.

## PRODUCT SERVICE

**Warning Concerning Removal of Covers.**

The unit should be serviced by qualified technicians only.

Your product is designed and manufactured to ensure a minimum of maintenance.

Should your unit require service or parts, call Panasonic Call Center at 1-866-292-7292 (USA) or 1-800-669-5165 (Canada).

---

**Panasonic Corporation of North America**  
One Panasonic Way, Secaucus, New Jersey 07094  
[www.panasonic.com](http://www.panasonic.com)

**Panasonic Canada Inc.**  
5770 Ambler Drive, Mississauga, Ontario L4W 2T3  
[www.panasonic.ca](http://www.panasonic.ca)

© Panasonic corporation 2011  
Printed in China

T0511-0 08VQC5420