



EV9795-90

# E-20 Prefilter System

Prefilter System for foodservice applications



E-20 Prefilter System: EV9795-90

EC210 Prefilter Cartridge: EV9534-26

## BENEFITS

- Filters out larger dirt and rust particles
- Extends the life of primary filter cartridges
- Tightly spun EC210 sediment cartridge delivers 10 micron nominal filtration
- Durable slim bowl design makes cartridge change outs easy to handle
- Clear housing lets you visually inspect trapped particles and makes determining when to change the cartridge easy
- 20" bowl design accepts most 10" drop in cartridges

## INSTALLATION TIPS

- Choose a mounting location suitable to support the full weight of the system when operating
- Make sure to properly lubricate O-ring prior to use
- Use 3/4" water line (Optional reducer bushings included)
- Install vertically with bowl hanging down
- Allow 2-1/2" clearance below the cartridge for easy cartridge replacement

## OPERATION TIPS

- Inspect EC210 cartridge periodically to determine dirt load
- Replace EC210 cartridge when dirt has penetrated through to the inner core of the cartridge
- Do not exceed service flow rate
- Inspect O-ring during each cartridge change. Lubricate and/or replace if necessary

## APPLICATION/SIZING

- For all foodservice applications requiring prefiltration
- High sediment areas

# E-20 Prefilter System

## SPECIFICATIONS

Overall Dimensions:  
22.44"H x 5.16"W x 5.5"D

Inlet connection: 3/4"

Outlet connection: 3/4"

Service Flow Rate:  
Maximum 6.0 gpm (22.7 Lpm)

Pressure Requirements:  
10 - 125 psi (0.7 - 8.6 bar), non-shock

Temperature: 35 - 100°F (2 - 38°C)

No electrical connection required

Shipping Weight: 6 lbs.

Operating Weight: 8 lbs.

The contaminants or other substances removed or reduced by this drinking water system are not necessarily in your water. Do not use with water that is microbiologically unsafe or of unknown quality without adequate disinfection before or after the system. Systems certified for cyst reduction may be used with disinfected water that may contain filterable cysts.

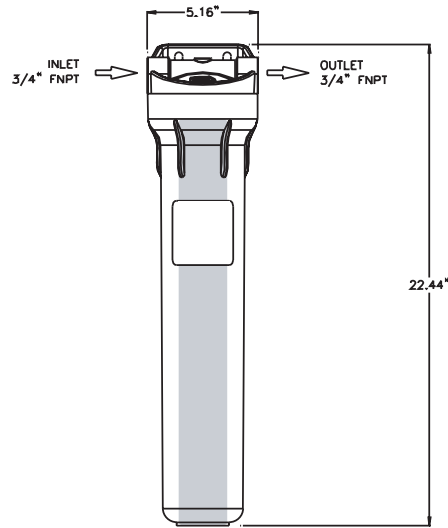

## WARRANTY

Everpure water treatment systems (excluding replaceable elements) are covered by a limited warranty against defects in material and workmanship for a period of five years after date of purchase. Everpure replaceable elements (filter cartridges and water treatment cartridges) are covered by a limited warranty against defects in material and workmanship for a period of one year after date of purchase. See printed warranty for details. Everpure will provide a copy of the warranty upon request.

### EVERPURE®

EVERPURE, LLC  
1040 Muirfield Drive  
Hanover Park, Illinois 60133  
Toll Free (800) 323-7873  
Tel (630) 307-3000  
Fax (630) 307-3030  
<http://www.everpure.com>

*In Europe:*  
N.V. EVERPURE (EUROPE) S.A.  
INDUSTRIEPARK WOLFSTEE  
TOEKOMSTLAAN 30  
B-2200 HERENTALS  
BELGIUM  
TEL 32 -14-283500  
FAX 32-14-283505

*In Japan:*  
EVERPURE JAPAN LLC  
HASHIMOTO MN BLDG. 7F  
3-25-1 HASHIMOTO SAGAMIHARA-SHI  
KANAGAWA 229-1103  
JAPAN  
TEL 81-(0)42-775-3011  
FAX 81-(0)42-775-3015

Everpure  
1040 Muirfield Drive  
Hanover Park, IL 60133  
Phone: 630-307-3020 Fax: 630-307-3030