



EV9637-01

MicroGuard™ Pro 2 Filter

Delivers premium quality drinking water for bottleless coolers and drinking fountains



MicroGuard™ Pro 2 Replacement Cartridge:
EV9637-01

BENEFITS

Everpure's multi-stage filter for drinking water applications combines membrane and carbon block technology for superior filtration results down to 0.15 microns

Capillary membrane filtration reduces 99.9999% of bacteria, asbestos fibers, and cysts such as Cryptosporidium and Giardia

Submicron filtration reduces dirt and particles

Delivers taste, odor and chlorine reduction

Reduces wear and abrasion on coolers and other water-using equipment

Sanitary cartridge replacement is simple, quick and clean. Internal filter parts are never exposed to handling or contamination

INSTALLATION TIPS

- Never use saddle valve for connection
- Use 3/8" water line
- Install vertically with cartridge hanging down
- Allow 2-1/2" clearance below the cartridge for easy cartridge replacement
- Flush MicroGuard™ Pro 2 cartridge by running water through filter for three minutes at full flow

OPERATION TIPS

- Change cartridges on a regular 6 month preventative maintenance program
- Change cartridges when capacity is reached or when pressure falls below 10 psi
- Service flow rate must not exceed 1 gpm
- Always flush the filter cartridge at time of installation and cartridge change

APPLICATION/SIZING

- For smaller capacity coolers and drinking water applications
- Rated Capacity: 2,200 gallons (8,330 L)

MicroGuard™ Pro 2 Filter

SPECIFICATIONS

Overall Dimensions:
10.25"H x 3.25"Diameter

Service Flow Rate:
Maximum 1 gpm (3.8 Lpm)

Rated Capacity: 2,200 gallons (8,330 L)

Pressure Requirements:
10 - 125 psi (0.7 – 8.6 bar), non-shock

Temperature: 35 - 100°F (2 - 38°C)

No electrical connection required

The contaminants or other substances removed or reduced by this drinking water system are not necessarily in your water. Do not use with water that is microbiologically unsafe or of unknown quality without adequate disinfection before or after the system. Systems certified for cyst reduction may be used with disinfected water that may contain filterable cysts.

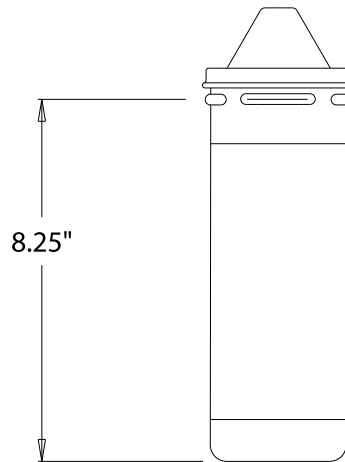

WARRANTY

Everpure water treatment systems (excluding replaceable elements) are covered by a limited warranty against defects in material and workmanship for a period of five years after date of purchase. Everpure replaceable elements (filter cartridges and water treatment cartridges) are covered by a limited warranty against defects in material and workmanship for a period of one year after date of purchase. See printed warranty for details. Everpure will provide a copy of the warranty upon request.



EVERPURE, LLC
1040 Muirfield Drive
Hanover Park, Illinois 60133
Toll Free (800) 323-7873
Tel (630) 307-3000
Fax (630) 307-3030
<http://www.everpure.com>

In Europe:
N.V. EVERPURE (EUROPE) S.A.
INDUSTRIEPARK WOLFSTEE
TOEKOMSTLAAN 30
B-2200 HERENTALS
BELGIUM
TEL 32 -14-283500
FAX 32-14-283505

In Japan:
EVERPURE JAPAN LLC
HASHIMOTO MN BLDG. 7F
3-25-1 HASHIMOTO SAGAMIHARA-SHI
KANAGAWA 229-1103
JAPAN
TEL 81-(0)42-775-3011
FAX 81-(0)42-775-3015

Everpure
1040 Muirfield Drive
Hanover Park, IL 60133