



AEROMATIC™ SERIES STANDARD RESIDENTIAL E150-TR Energy Recovery Ventilator

PRODUCT
SPECIFICATIONS
& TECHNICAL
DATA



PRODUCT DESCRIPTION

Compact size, large performance – the E150-TR energy recovery ventilator produces approximately **150 CFM** at 0.20 in.w.g (ESP) and recovers sensible and latent heat through its high-efficiency polymeric membrane core. The E150-TR has been thoughtfully engineered for simple installation in apartments, condos, and small houses. The removable collars are top-mounted, which makes the unit both narrow and shallow enough to fit inside standard closets and other tight spaces.

The E150-TR has two exclusive features. EvacMAX™ provides on-demand boost for maximum ventilation. With FLEXControl, airflow circuits can be calibrated electronically, eliminating the need for resistance-inducing balancing dampers and improving overall efficiency.

KEY FEATURES

- Damage-free packaging protects the unit in transit and makes it easy to remove it from the carton without damaging the collars
- Electronically and independently adjustable supply and exhaust blowers (FLEXControl)
- Gauge ports on the door for fast and reliable airflow readings
- Twist-in collars for easy flex-duct attachment
- Non-dust-loading backward-inclined impellers on totally enclosed motors
- Snap-out motor decks
- Easy access to core and filters for cleaning
- Extremely durable core
- Standard MERV 6 filters
- Multiple low-cost controller options for occupancy changes
- Recirculating defrost collar snaps into pre-punched area of cabinet for ducting flexibility

CASING

Material: Pre-painted 24-gauge galvanized steel
Drain Connection: Ø 3/8" (Ø 10 mm)
Duct Diameter: Ø 5" (Ø 127 mm)
Insulation: Molded EPS
Width: 23-1/8" (587 mm)
Height: 16-3/4" (425 mm)
Depth: 12-3/8" (314 mm)
Weight: 32 lbs (15 kg); Shipping Weight: 40 lbs (18 kg)
Supply Damper: Motorized

MOUNTING

- Suspended by chains with vibration-isolating springs
- Wall-mounting accessory available (P/N 608575)

RECOVERY CORE

Material: Polymeric Membrane

BLOWERS

Quantity: 2
Type: Motorized impellers (backward-inclined)

ELECTRICAL REQUIREMENTS

120 VAC, 60 Hz, 1.3 A, 156 W
Cord Set: 48" (1219 mm) with ground

CONTROLS

Low voltage dry contact (24VAC) for:

- Fan interlock (NO and NC)
- LCD Electronic Multifunction Control (P/N 611227)
- Mode Control (Recirculation) (P/N 611230)
- Humidity Control (P/N 611224)
- Speed Control (Low/Intermittent/High) (P/N 611229)
- 20/40/60 Minute Timer (P/N 611228)

FROST CONTROL

- Automatic timed recirculation, fifth port
- Cycles controlled by a temperature sensor when the outdoor temperature drops below 14°F (-10°C)

FILTERS

Quantity: 2
Type: MERV 6 (P/N 612409)

WARRANTY

Core Assembly: Limited 5-year warranty
All Other Covered Components: Limited 5-year warranty

APPROVALS

Meets Standards:
• C22.2 no113 and UL 1812



Dimensions

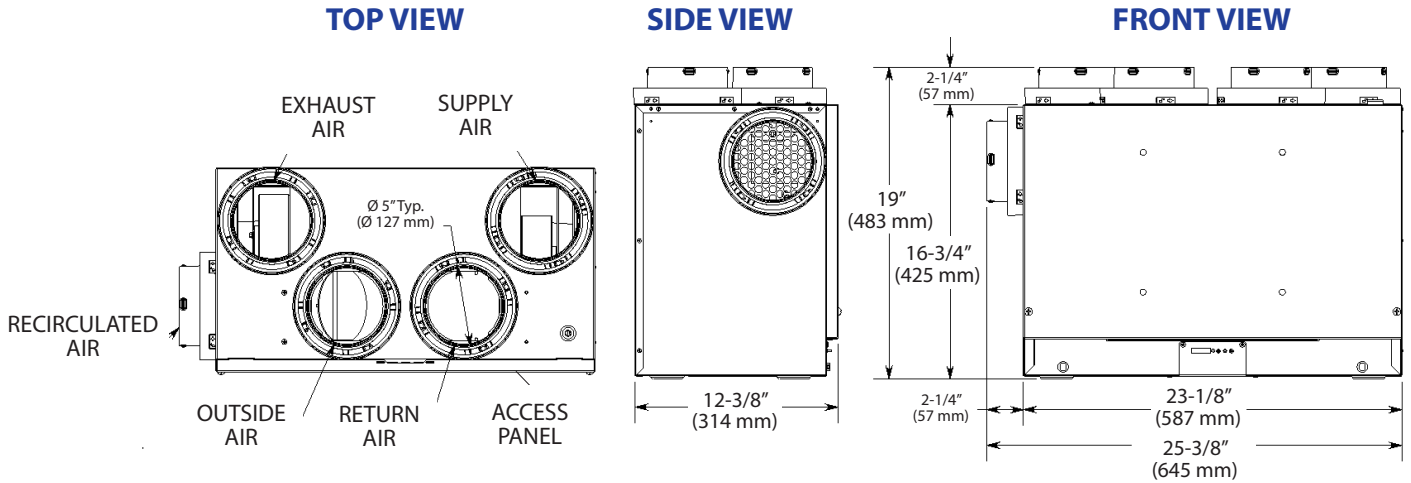

Performance

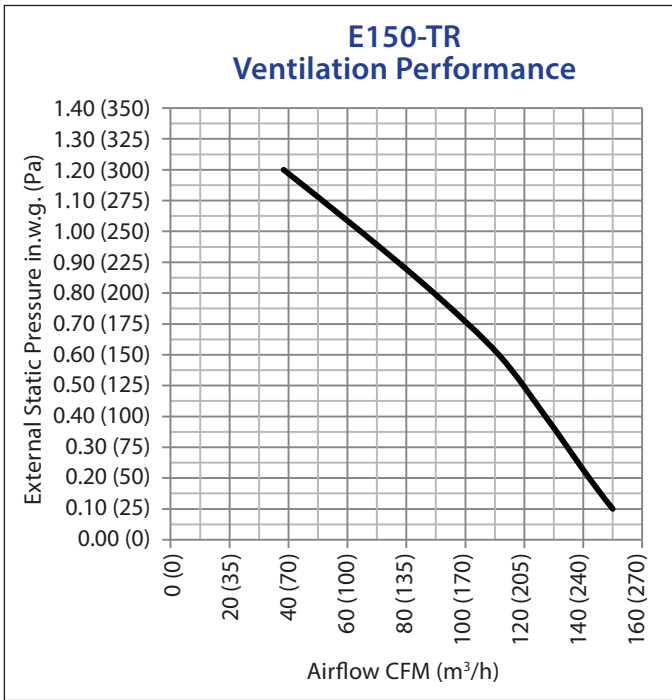

Energy Performance						
Outside Air Temperature		Net Airflow		Sensible Recovery Efficiency	Latent Recovery/Moisture Transfer	Total Energy Recovery
°F	°C	CFM	L/s			
Heating						
35	1.7	70	35	60%	33%	51%
35	1.7	120	57	55%	27%	45%
35	1.7	160	76	51%	24%	42%
Cooling						
95	35	70	35	60%	29%	41%
95	35	120	57	55%	23%	35%
95	35	160	76	51%	20%	32%

Project:		Architect:	
Location:		Engineer:	
Model #:		Contractor:	
Quantity:		Comments:	
Submitted By:			
Date:			

© 2013 American ALDES Ventilation Corporation. Reproduction or distribution, in whole or in part, of this document, in any form or by any means, without the express written consent of American ALDES Ventilation Corporation, is strictly prohibited. The information contained within this document is subject to change without prior written notice.