

SPEC # _____

QUANTITY _____

APPLICATION

MULTIPLE EQUIPMENT



AT A GLANCE

Aqua-Pure[®] Model DP290 DUAL-PORT water filtration system assures consistent high-quality water for the multiple applications of cold beverages, ice, and coffee at a combined flow rate to 10 gpm (37.8 lpm). Two separate streams exit the manifold. Both streams have reduced sediment and chlorine taste and odor. One stream has scale-inhibition media added from a dedicated cartridge to reduce the ability of calcium and magnesium to precipitate as hard scale on the evaporator plates of an ice machine and/or the heating coils of a coffee brewer. The other stream supplies cold beverage dispensers and includes no added scale inhibitor.

- DP290 combines chlorine taste and odor reduction with cyst, bacteria and sediment reduction, and provides protection from the harmful effects of scale for total volumes up to 108,000 gallons (408,823 liters).

PRODUCT BENEFITS

- One system with dual outlet connections simultaneously supplies cold beverage dispensers and ice machines/coffee brewers.
- Up to 10 gpm (37.8 lpm) total flow of water especially treated for consistent great-tasting cold beverages, clear and consistent ice, and the perfect cup of coffee or tea.
- Revolutionary IMPACTechnology™ dual-zone media cartridge construction combines a membrane in series with premium activated carbon to provide unsurpassed throughput and cartridge life.
- Cartridge Life Warranted*.
- Certified by NSF to Standard 53 for cyst reduction.
- NSF Standard 42 and/or FDA CFR-21 compliance provides assurance of safety.
- The removal of over 99.99% water-borne heterotrophic bacteria by membrane filtration as tested by CUNO.
- Reduced scale build-up on evaporator plates and heating coil from the carefully-controlled (forced-orifice) addition of scale inhibitor as tested by CUNO.
- SQC™ – Sanitary Quick Change – encapsulated cartridge design allows for fast and easy change-outs with a 1/4 turn while minimizing the possibility of leakage and contamination.
- 3/4" FNPT horizontal inlet and outlet ports allow direct or easily adaptable connections to existing plumbing lines.
- Auxillary inlet gauge port allows optional monitoring of differential water pressure.
- Exhausted cartridges may be incinerated for environmentally conscious disposal.

PRODUCT SPECIFICATIONS

Model Number	Part Number	Reduction Claims	Micron Rating	Capacity	Service Flow Rate	Application	Replacement Cartridge	Sizing
DP290	56165-01	Cyst, Bacteria, Sediment, Chlorine Taste & Odor, Scale	0.2'	108,000 gals. (408,823 lit.)	10.0 gpm (37.8 lpm)	Most Normal Water	DP290 CARTPAK: 56138-02	For simultaneous operation of carbonators, coffee machines and ice machines.

* See Aqua-Pure Commercial Products Price Book for Terms and Conditions
 † NSF Certified for Particulate, Class I



a 3M company



Aqua-Pure® Commercial Products

SPEC # _____
QUANTITY _____
MODEL NUMBER _____
PART NUMBER _____

Aqua-Pure®
COMMERCIAL PRODUCTS
DP290

PHYSICAL SPECIFICATIONS

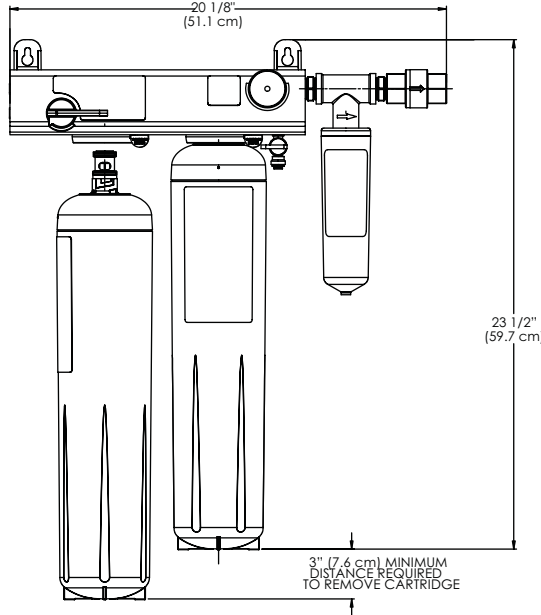

- System includes a two-cartridge manifold with built-in pressure gauge, inlet water shut-off valve, outlet check valve, mounting brackets, two cartridge filters and a dedicated external scale-inhibition cartridge.
- Auxillary inlet gauge port allows optional monitoring of differential water pressure.
- Inlet and outlet plumbing connections to the mounted head are 3/4" FNPT.
- Large filter cartridges are double o-ring seal type.
- System maximum operating pressure of 125 psi (862 kPa) and operating temperature of 100°F (38°C).
- Recommended service flow rate is up to 10.0 gpm (37.8 lpm).
- Two large filter cartridges incorporate carbon block media protected by a pleated pre-filter membrane. Third cartridge includes scale-inhibitor media.
- System is NSF Standard 42 and/or CFR-21 compliant.
- Large cartridge bodies are constructed from high-impact glass-filled polypropylene.
- Cartridges are sanitary in design, requiring no contact with the filter media during cartridge change-out.
- Filter cartridges require no pre-activation.
- A NSF Performance Data Sheet (PDS) is included.
- Shipping weight: Contact Factory
- Operating weight: 28.9 lbs. (13.1 kg)

Do not use with water that is microbiologically unsafe or of unknown quality without adequate disinfection before or after the system. Systems certified for cyst reduction may be used on disinfected water that may contain filterable cysts. EPA Establishment Number 070595-CT-001.

CUNO Incorporated recommends regularly scheduled maintenance and replacement of the filter cartridge(s) in order for the product to perform as advertised/sold. Change the filter cartridge at least every 6 months. CUNO shall not be liable for system failures due to improper maintenance.

INSTALLATION TIPS

- Shut off downstream equipment prior to installation of the system.
- Choose mounting location to support full system weight when operating.
- Do not exceed operating parameters for temperature or pressure.
- Do not install outdoors.
- For commercial use only with cold water.

LIMITED 5 YEAR WARRANTY

CUNO Incorporated warrants to the original purchaser-consumer that this product is free from defects in materials and workmanship. This warranty, together with any and all warranties implied by law, shall be limited to a period of five (5) years from the date of original purchase by the consumer. This warranty does not apply to failures that result from abuse, misuse, alteration or damage not caused by CUNO. This warranty is subject to exclusions and limitations. Please refer to the Warranty Card provided with the product for details.

SERVICE WORLDWIDE

CHINA
CUNO Filtration Shanghai Co. Ltd.
No. 2 Plant East Side
Xin Miao San Road
Xinqiao Town SongJiang District
Shanghai, China 201612

JAPAN
CUNO K.K.
Hodogaya Station Building 6F
1-7, Iwai-Cho, Hodogaya-Ku
Yokohama 240-0023, Japan

AUSTRALIA
CUNO Pacific Pty Ltd.
140 Sunnyholt Road
Blacktown, N.S.W. 2148
Australia

BRAZIL
CUNO Latina Ltda
Rua AMF do Brazil - 251
18120 Mairinque-SP, Brazil

EUROPE
CUNO Limited
21 Woking Business Park
Albert Drive
Woking, Surrey
GU21 5JY, England

SINGAPORE
CUNO Filtration Asia Pte Ltd
2A Tuas Avenue 12
Singapore 639023



Visit www.nsf.org for the claims associated with products that are NSF listed.



CUNO Incorporated
400 Research Parkway
Meriden, CT 06450, USA
Toll Free: 1.888.218.CUNO
Worldwide: 203.237.5541
Fax: 203.238.8701
www.cunofoodservice.com