

Aprilaire[®]

COMMUNICATING THERMOSTATS

Installation Instructions

MODEL 8870

These instructions are for connecting the Thermostat to the HVAC equipment.

To connect communication features, please reference the Communicating Thermostat System Installation Manual.

INSTALLATION INSTRUCTIONS MANUAL

TABLE OF CONTENTS

Warning	1
Model 8870 Thermostat Specifications	2
1. HVAC System Pre-Installation Check List	2
2. What's In The Box	3
3. Select The Thermostat Location	3
4. Disassembly	4
5. Mount Base To Wall	5
6. Setting The Dip Switches	6
7. Wiring The Thermostat	7
8. Reassemble The Thermostat	9
9. HVAC System Check Out	9
10. Optional HVAC Set-Up Features	12
11. To Access The HVAC Set-Up Features	13
Wiring Diagrams	16 – 22
Note Pages	23 – 25

READ COMPLETE SAFETY & INSTALLATION INSTRUCTIONS BEFORE STARTING

WARNING

1. 120-volts may cause serious injury from electrical shock. Disconnect electrical power to the furnace and air conditioner before starting installation. This thermostat is not a 120-volt (line voltage) device.
2. Improper installation may cause serious injury from electrical shock. This product must be installed by a qualified heating and air conditioning contractor in accordance with NEC Standards and applicable local and state codes.
3. Mercury is toxic and may be hazardous to health. Any replaced thermostats containing mercury must be disposed of properly. Contact local authorities for disposal information.

MODEL 8870 THERMOSTAT SPECIFICATIONS:

Control Voltage	24V AC \pm 20%
Switched Voltage	18 – 30V AC
Maximum Operating Current	2.0A total at rated voltage, through all outputs. 1.0A through any one output.
Maximum Surge Current	2.0A
Control Accuracy	\pm 1.0°F
Control Range	40° – 90°F
Operating Range	32° – 99°F

1. HVAC SYSTEM PRE-INSTALLATION CHECK LIST

Before getting started determine what type of heating system is/will be installed in the house. Then use *Table 1* to determine if the proper numbers of wires are available depending on the HVAC System. Additional wires will be required for communication system.

TABLE 1

APPLICATION	# OF HVAC WIRES	DIAGRAM	PAGE #
Single Stage Furnace & AC	5	1	16
Two Stage Furnace & Two Stage AC	7	2	17
Roof Top Unit (Two Stage Heat & Two Stage Cool)	7	3	18
Boiler with AC (Two Transformers)	5	4	19
Single Stage Heat Pump	7	5	20
Two Stage Heat Pump	9	6	21
First Stage Radiant Floor Heat Second Stage Furnace One Stage of Cooling	6	7	22

2. WHAT'S IN THE BOX

- Thermostat (*Figure 1*): front panel, cover, and base
- Installation Manual
- Owners Manual
- Hardware bag: screws and wall anchors

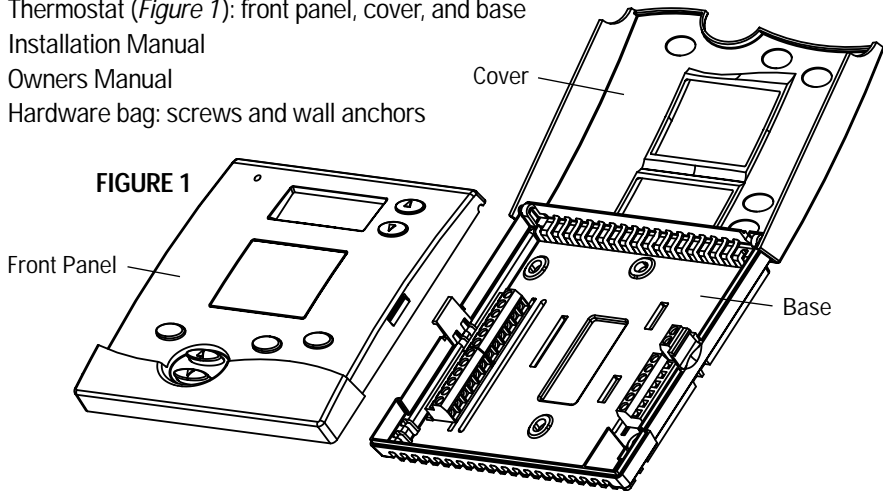

3. SELECT THE THERMOSTAT LOCATION

Determine if the thermostat will be operating alone, or with remote temperature sensors. If the unit is stand-alone there are certain measures that must be taken to ensure accurate temperature control.

STAND-ALONE THERMOSTAT MOUNTING CRITERIA:

- Mount on an interior wall.
- In a room frequently occupied.
- At least 18 inches from any outside wall.
- Approximately 5 feet above the floor. Check with local building codes for height requirements in commercial requirements.

DO NOT locate the thermostat:

- Behind doors, in corners or other dead air spaces.
- In direct sunlight or near lamps, appliances or other sources of radiant heat.
- On an outside wall or wall exposed to an unconditioned space (i.e. garage, etc.).
- In the flow path of a supply register, in stairways or near outside doors.
- On a wall where concealed pipes and/or ductwork will affect the thermostat.
- Near sources of electrical interference such as arcing relay contacts.

WITH REMOTE TEMPERATURE SENSORS

Follow the guidelines for placement of the sensors and locate the thermostat indoors where operating range (see specs) will not be violated (i.e. do not install in a cold garage or hot equipment room). See the sensor installation literature for additional details.

4. DISASSEMBLY

No tools required – use hands to pull the front panel off of the base (*Figure 2*). While holding the base of the thermostat, apply pressure to the base of the latch with your thumb (*Figure 3*). Both sides have a latch, but it is easiest to unlatch one side at a time.

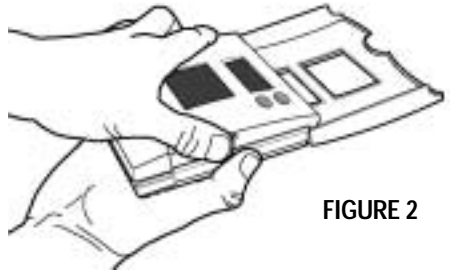
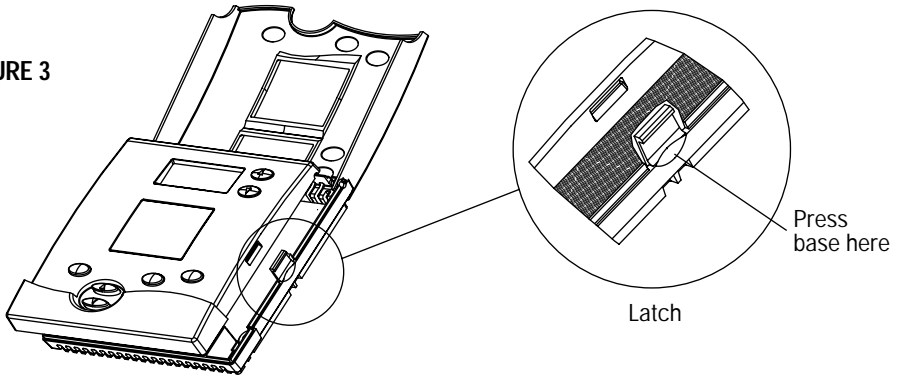

FIGURE 2

CAUTION: Loss of internal programs may result from static discharge to thermostat circuit board. Installer must touch a grounded metal object before handling the circuit board.

FIGURE 3



5. MOUNT BASE TO WALL

There are four screw holes located on the base of the thermostat; two are for a junction box mounting, along with two for alternate mounting spacing. Use one of the holes on the top and one on the bottom.

- a) Place the base over the wire hole opening in the wall; level the base and mark the screw hole mounting locations (leveling required for appearance only).
- b) If using supplied wall anchors, drill $3/16"$ hole in the center of the marked locations and tap in the wall anchors. If using the supplied screws only, drill a $3/32"$ hole in the center of the marked locations.
- c) Fasten the base to the wall with the supplied screws.
- d) Seal wire entry using caulk, drywall putty or insulation.

CAUTION: Minimize wire entry hole size and seal – drafts from inside the wall could affect temperature readings.

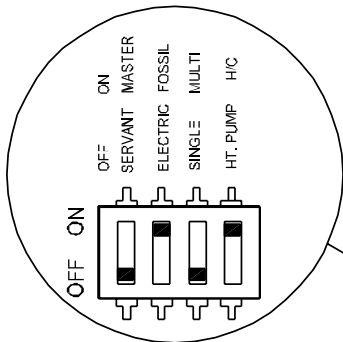
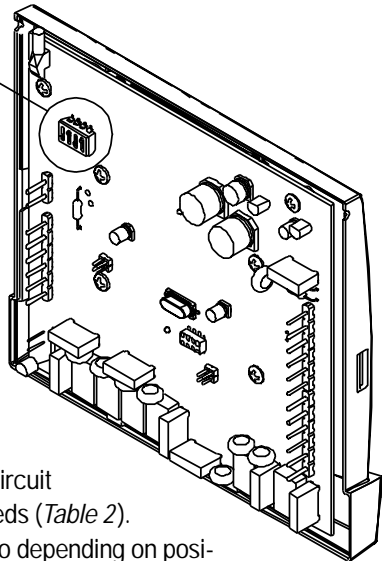

FIGURE 4



6. SETTING THE DIP SWITCHES

Set the dip switches located on the thermostat circuit board (Figure 4) according to the application needs (Table 2).

Figure 4 shows what each switch corresponds to depending on position. Switch one should be set in the “OFF Servant” position unless you plan to broadcast readings from remote temperature sensors to other thermostats in the system when there is no communication system in place.

TABLE 2

APPLICATION	SWITCH #1	SWITCH #2	SWITCH #3	SWITCH #4
Single Stage Furnace & AC	Servant	Fossil	Single	H/C
Two Stage Furnace & Two Stage AC	Servant	Fossil	Multi	H/C
Roof Top Unit (Two Stage Heat & Two Stage Cool)	Servant	Fossil	Multi	H/C
Boiler with AC (Two Transformers)	Servant	Fossil	Single	H/C
Single Stage Heat Pump	Servant	Electric	Single	HT. Pump
Two Multi-stage Heat Pump	Servant	Electric	Multi	HT. Pump
First Stage Radiant Floor Heat Second Stage Furnace One Stage of Cooling	Servant	Fossil	Multi	H/C

7. WIRING THE THERMOSTAT

- a) Strip 1/4" of insulation from each wire to be used. *Figure 5* shows all wiring terminal definitions.
- b) Secure wires into the terminals on the base according to the appropriate wiring diagram (*Table 3*). Use color-coding practices (i.e. white wire to W terminal) whenever possible.

TABLE 3

APPLICATION	DIAGRAM	PAGE #
Single Stage Furnace & AC	1	16
Two Stage Furnace & Two Stage AC	2	17
Roof Top Unit (Two Stage Heat & Two Stage Cool)	3	18
Boiler with AC (Two Transformers)	4	19
Single Stage Heat Pump	5	20
Two Stage Heat Pump	6	21
First Stage Radiant Floor Heat Second Stage Furnace One Stage of Cooling	7	22

FIGURE 5

COMMUNICATION TERMINAL DEFINITIONS

(refer to Aprilaire HVAC Automation System Install Manual for communication wiring details)

- B+/B-** RECEIVE (reference automation system)
- A+/A-** TRANSMIT (reference automation system)
- REF** GROUND REFERENCE
- R** THERMOSTAT VOLTAGE (hot)
- C** THERMOSTAT VOLTAGE (common)

SENSOR TERMINAL DEFINITIONS

(refer to sensor literature for wiring details)

- RSA/RSB** SENSOR COMMUNICATION (half duplex)
- RSR** THERMOSTAT VOLTAGE (hot)
- RSC** THERMOSTAT VOLTAGE (common)

EQUIPMENT TERMINAL DEFINITIONS

- RH** SWITCHED VOLTAGE (HEAT)
- RC** SWITCHED VOLTAGE (COOL)
- RV COOL** REVERSING VALVE - COOL (Energized in COOL mode)
- (O)**
- RV HEAT** REVERSING VALVE - HEAT (Energized in other modes)
- (B)**
- G** FAN
- DEH/Y1** 1st STAGE COOLING (non-heat pump) OR 1st STAGE COMPRESSOR (heat pump) OR DEHUMIDIFICATION (with humidity control sensor)
- Y2** 2nd STAGE COOLING (non-heat pump) OR 2nd STAGE COMPRESSOR (heat pump)
- HUM/W1** 1st STAGE HEAT (non-heat pump) OR 3rd STAGE HEAT AND 1st STAGE EMERG. HEAT (heat pump) OR HUMIDIFICATION (with humidity control sensor)
- W2** 2nd STAGE HEAT (non-heat pump) OR 2nd STAGE EMERGENCY HEAT (heat pump)

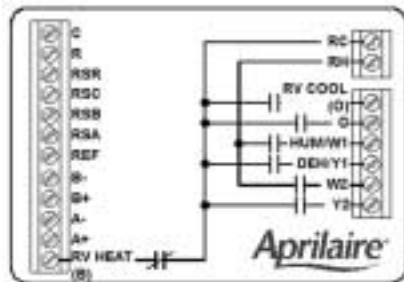
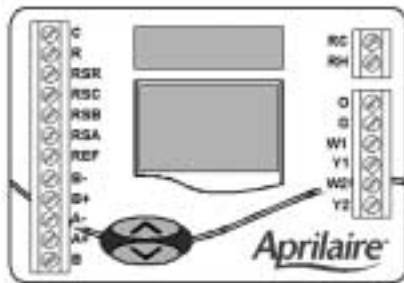

7. WIRING THE THERMOSTAT (Cont.)

- c) Check each wire to ensure it is securely fastened, not broken, and exposed wires are not touching.

8. REASSEMBLE THE THERMOSTAT

No tools required – line up pins on circuit board with the corresponding terminal blocks. Use your hands to push the front panel securely to the mounted base.

CAUTION: Loss of internal programs may result from static discharge to thermostat circuit board. Installer must touch a grounded metal object before handling the circuit board.

9. HVAC SYSTEM CHECK OUT

HVAC installer may need to connect 24V AC to the R and C terminals to check HVAC operation. If the automation system is to be installed **after** the HVAC installation, leave the R and C terminals connected to ensure the HVAC system operates. If the automation system is installed **before** the HVAC wiring, then do not connect HVAC wires to R and C.

When the thermostat is first turned on all of the graphics of the main LCD are momentarily displayed; this will look like *Figure 6*.

FIGURE 6

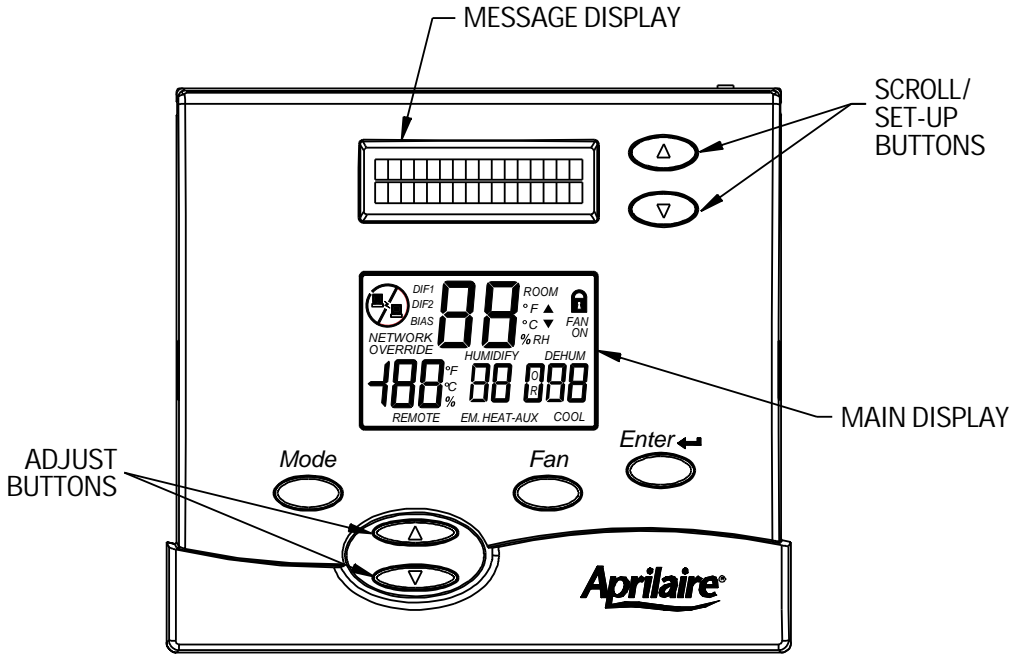









Use the Check Out Procedure (*Figure 7*, on the next page) to determine if the thermostat is controlling the HVAC equipment.

FIGURE 7

CHECK-OUT PROCEDURE

CAUTION: The following check-out procedure will turn the heating and cooling equipment on and off. Do not operate in cooling at low outdoor temperatures. Do not operate in heating at high outdoor temperatures. Refer to equipment manufacturer specifications for safe operating temperatures.

STEP	PRESS	LOOK FOR...	NOTES AND REACTION
1		OFF	Press the Mode button repeatedly until OFF appears on the display.
2		FAN ON	Press the Fan button. System blower should start and FAN ON appears on display. Press again to stop.
3		80 COOL	Press the Mode button until COOL appears along with the current cool setting.
4		77 COOL	Use the down arrow to lower the set point 3°F below room temp. In 5-10 seconds the first stage of cooling begins and the COOL icon begins to flash. If there is a second stage it will begin in 4 minutes.
5		OFF	Press the Mode button until OFF appears on the display. You must change the mode to override the Minimum On time delays.
6		68 HEAT	Press the Mode button until HEAT appears along with the current heat setting.
7		71 HEAT	Use the up arrow to raise the set point 3°F above room temp. In 5-10 seconds the first stage of heating begins and the HEAT begins to flash. If there is a second stage it will begin in 4 minutes.
7A		HEAT -AUX	"-AUX" comes on when the auxiliary heat terminal (W1) is energized. The LED on top of thermostat will illuminate.
	HEAT PUMP ONLY		
8		OFF	Press the Mode button until OFF appears on the display. During Check-out, change the mode to override the Minimum On time delays.
9		EM. HEAT	Press Mode button until EM. HEAT appears on display. Repeat step 7 to verify Emergency Heat operation.
	HEAT PUMP ONLY		

10. OPTIONAL HVAC SET-UP FEATURES

There are a number of HVAC features that can be configured for the particular application. These include temperature control options, display options and high/low balance points (heat pumps only).

A) TEMPERATURE CONTROL OPTIONS

1. **OFFSET** – allows the user to offset the displayed room temperature $\pm 3^{\circ}\text{F}$ from true temperature. This thermostat is calibrated to be within $\pm 1^{\circ}\text{F}$ of true temperature.
2. **1ST STAGE DIFFERENTIAL** – determines the level of control and consequently the cycle rate. Adjustable between 0.5°F and 2.0°F , this is the value above/below the set point that the temperature must rise (fall) to start the cooling (heating). It is also the value below (above) the set point that the temperature must fall (rise) for the cooling (heating) to stop. For example, if the temperature setting was 70°F and the 1st stage differential was set at 0.5°F , in the heat mode the heat would come on at 69.5°F and stay until the temperature was 70.5°F . A small differential will result in a tighter control, but more heating/cooling cycles.
3. **2ND STAGE DIFFERENTIAL** – again adjustable between 0.5°F and 2.0°F , this also determines the level of control by determining when to use the 2nd stage of heating or cooling. It can also be used to keep 2nd stage cooling from coming on too soon when 1st stage is acting to control temperature levels or to keep costly auxiliary heat from coming on too soon when the heat pump is sufficient.

B) BALANCE POINTS

These values are adjustable, but are only used by the thermostat when it has been configured to operate as a heat pump and when a remote outdoor temperature sensor, with address #1, is wired to the thermostat.

B) BALANCE POINTS (Cont.)

1. **LOW BALANCE POINT** – the outdoor temperature below which compressor terminals will not be energized.
2. **HIGH BALANCE POINT** – the outdoor temperature above which the auxiliary heat terminal will not be energized in the HEAT mode (does not effect Emergency Heat operation).

C) DISPLAY OPTIONS

1. **TEMPERATURE SCALE** – all temperatures displayed including room temperatures and set points can be °F or °C.
2. **SHOW TEMPERATURE SET POINTS ALWAYS** – keeps the temperature settings visible on the display at all times.
3. **SHOW TEMPERATURE SET POINTS ONLY IF CHANGED** – displays the temperature settings (heat and/or cool) only when the user changes them. The first press of either the up or down adjust buttons will display the settings.
4. **SHOW DATE AND TIME** – the message display will, by default, scroll three messages showing the status of the mode, fan and equipment outputs. A fourth date and time can be added to this list. However, the automation system must transmit the time and date to the thermostat at least once a day. If the automation system is not capable of doing this, the date and time can be configured not to show.

11. TO ACCESS THESE HVAC SET-UP FEATURES

When first powered up, the message display will scroll through the current mode status, fan status, and heating/cooling output status. This is referred to as Passive Display because you do not interact with it. To get into the Set-Up Menu, press the Enter button and Mode button at the same time. This is referred to as User Interactive Display, as the user navigates through various menu and sub-menu selections to change variables.

11. TO ACCESS THESE HVAC SET-UP FEATURES (Cont.)

Set-Up is menu driven but only one menu item is visible at a time. *Figure 8* shows the entire Main Menu. Selecting any one of the Main Menu items (by pressing the Enter button) will enter a corresponding Sub-Menu. *Figure 8* also shows the Temperature Set-Up, Balance Points Set-Up and Display Set-Up sub-menus expanded. The Scroll Up ▲ and Scroll Down ▼ buttons are used to move between menu items or change values. The Enter ◀ button is used to select a menu item or enter a value. When in Thermostat Set-Up, if none of the three navigation buttons are pressed in 5 minutes, the display will return to Passive Display. Again, you will only see one menu item at a time.

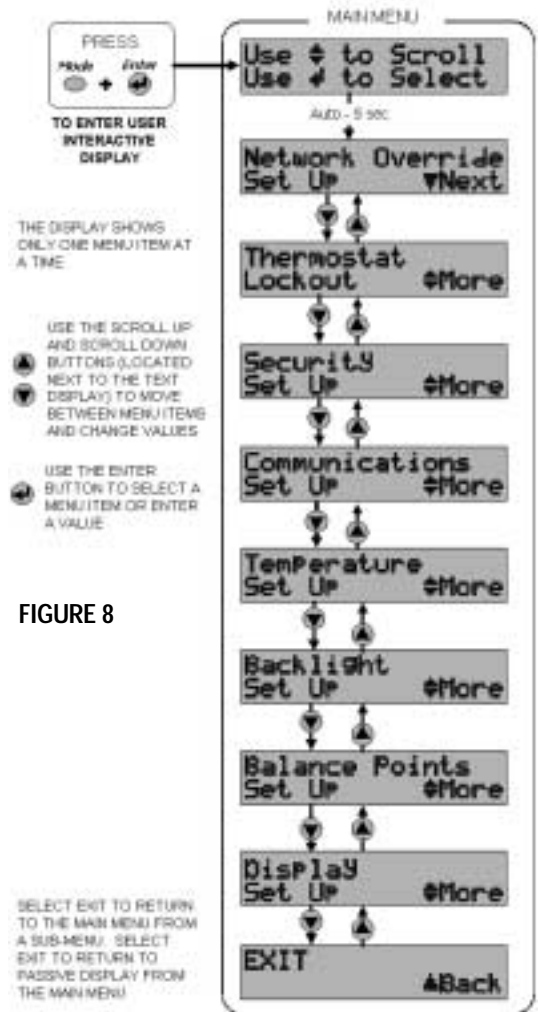

FIGURE 8

FIGURE 8 (Cont.)

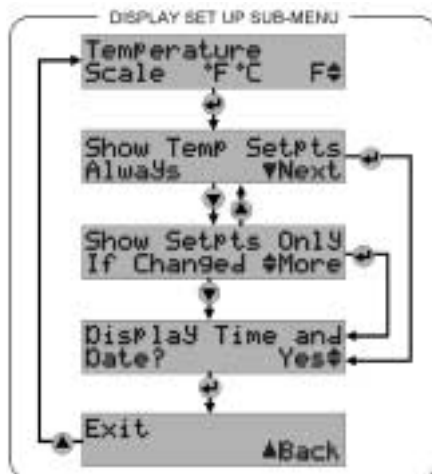
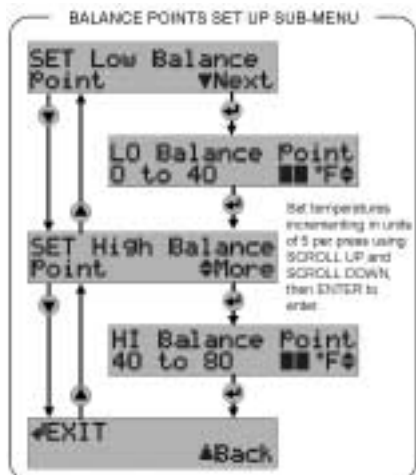
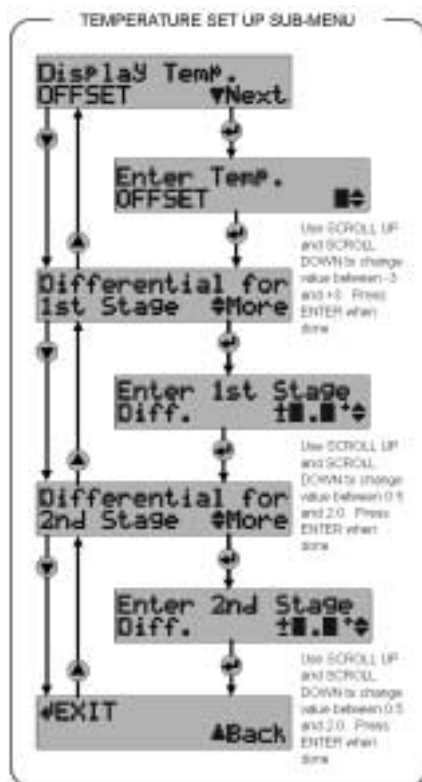
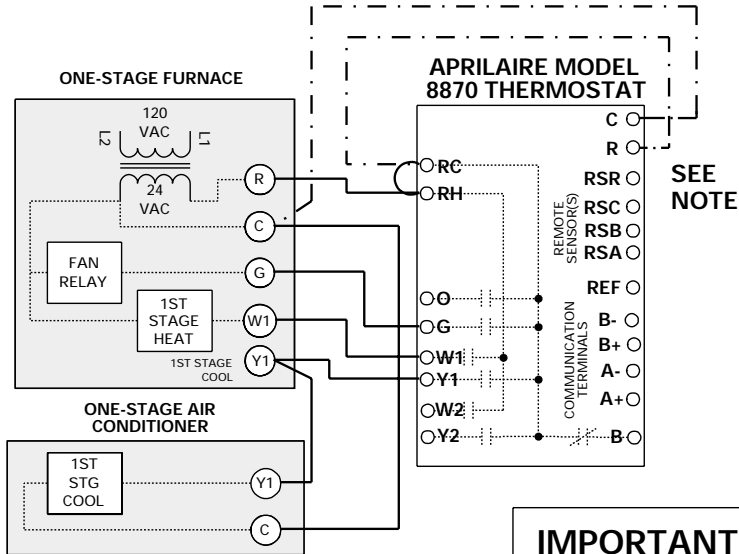

DIAGRAM 1 – SINGLE STAGE FURNACE AND AC



NOTE: HVAC installer may need to connect 24V AC to the R and C terminals to check the HVAC operation. If the automation system is to be installed after the HVAC installation, leave the R and C terminals connected to ensure the HVAC system operates. If the automation system is installed before the HVAC wiring, then **DO NOT** connect HVAC wires to R and C.

IMPORTANT!

The B terminal is for reversing valve-heat. **DO NOT** connect the B terminal to common side of transformer.

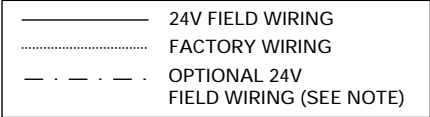

DIAGRAM 2 – TWO STAGE FURNACE AND TWO STAGE AC

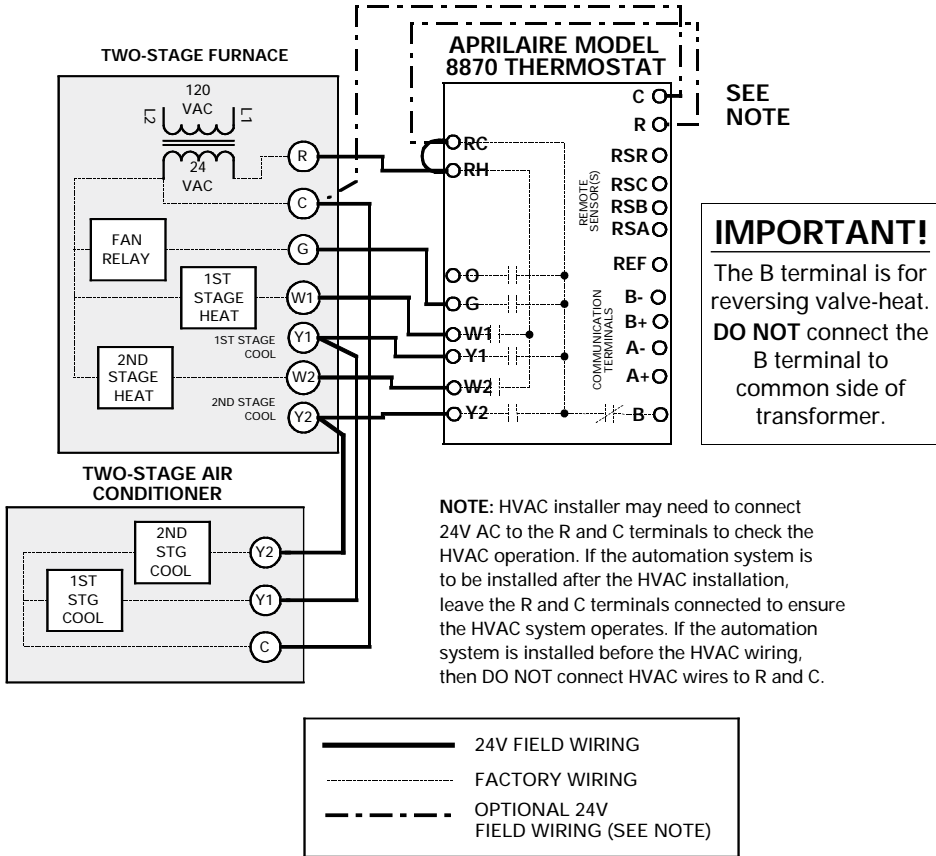

DIAGRAM 3 – ROOF TOP UNIT (TWO STAGE HEAT AND TWO STAGE COOL)

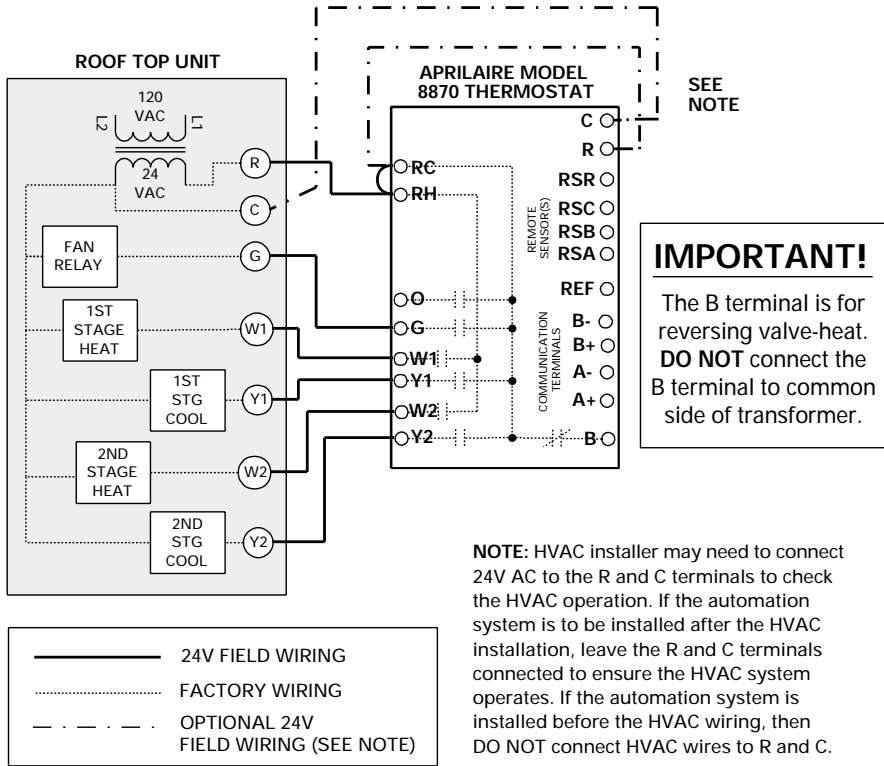
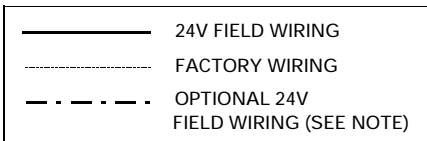
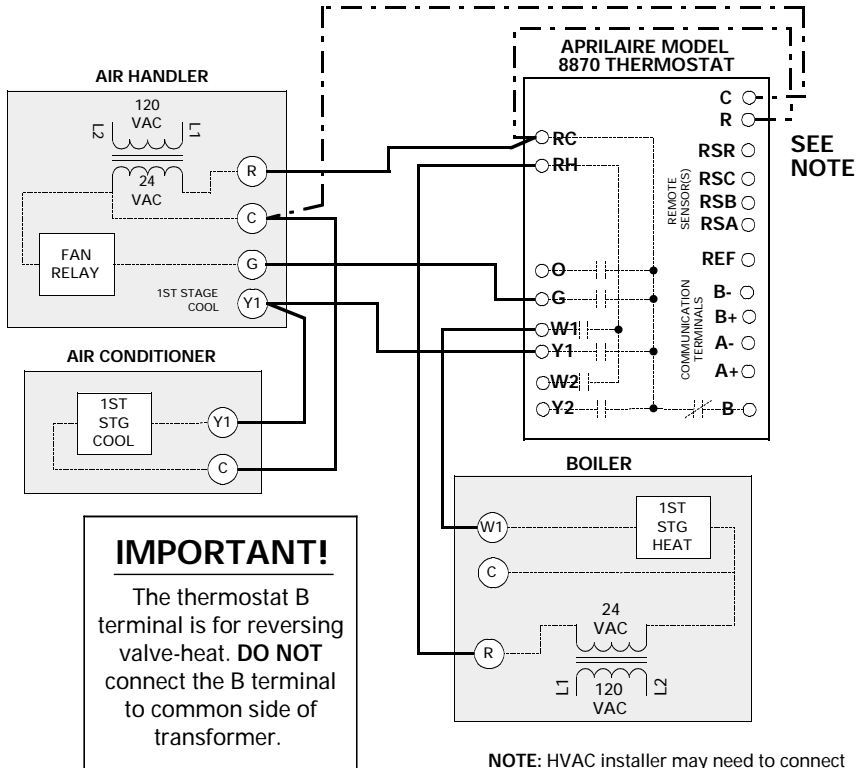

DIAGRAM 4 – BOILER WITH AC (TWO TRANSFORMERS)



NOTE: HVAC installer may need to connect 24V AC to the R and C terminals to check the HVAC operation. If the Automation system is to be installed after the HVAC installation, leave the R and C terminals connected to ensure the HVAC system operates. If the automation system is installed before the HVAC wiring, then **DO NOT** connect HVAC wires to R and C.

DIAGRAM 5 – SINGLE STAGE HEAT PUMP

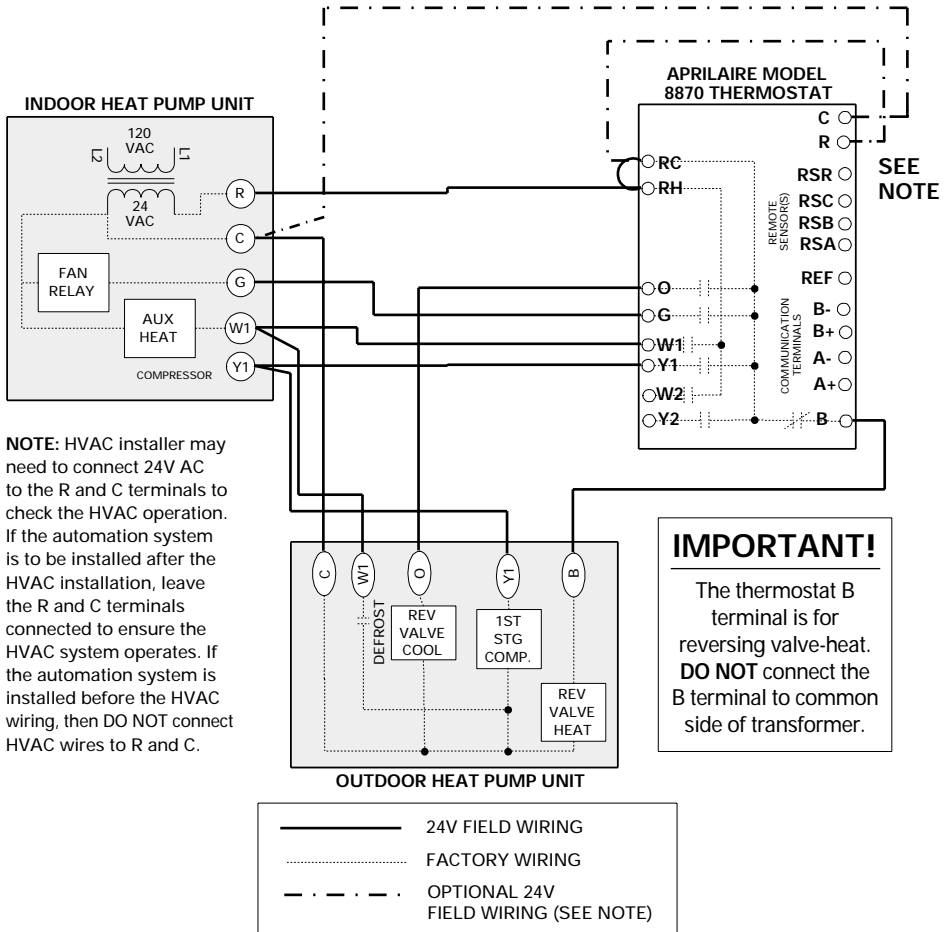

DIAGRAM 6 – TWO STAGE HEAT PUMP

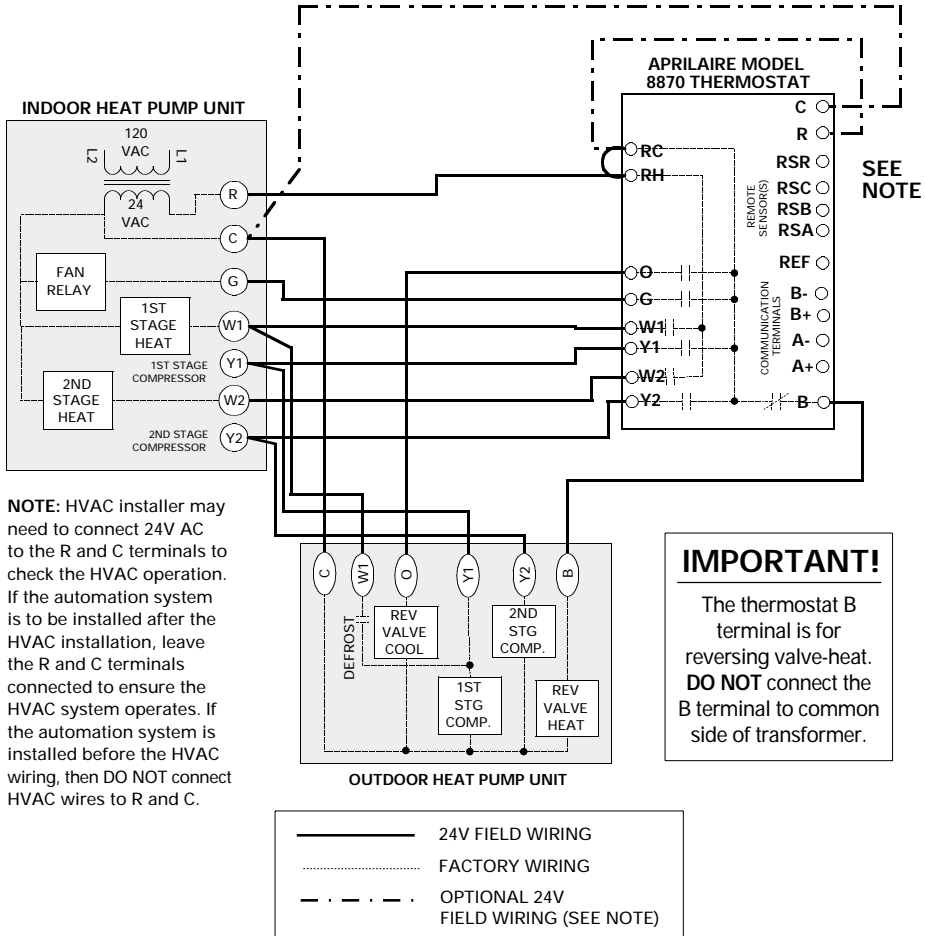
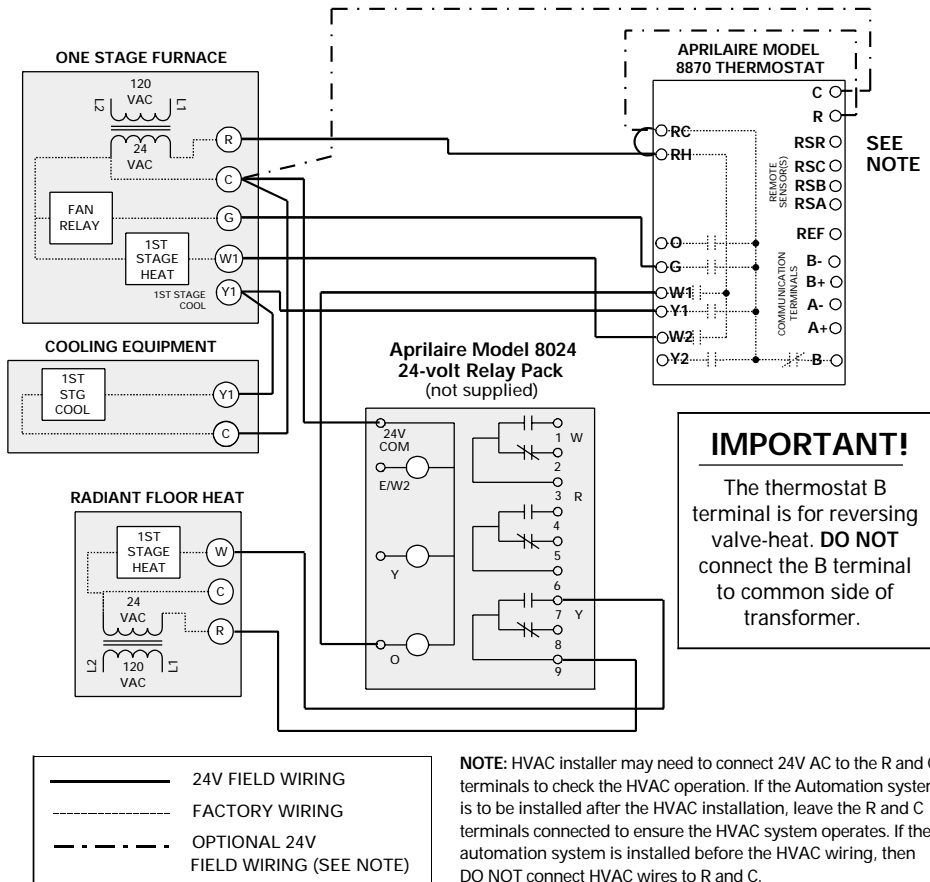

DIAGRAM 7 – FIRST STAGE RADIANT FLOOR HEAT SECOND STAGE FURNACE ONE STAGE OF COOLING



NOTES:

NOTES:

NOTES:

Aprilaire®

THE BEST IN INDOOR AIR COMFORT

The Aprilaire® Indoor Air Comfort System is an integrated group of air quality enhancement products designed to work with heating and cooling systems to make homes more comfortable. For the best in indoor air quality, install Aprilaire brand products, to solve your customers' Indoor Air Comfort needs.

Aprilaire® Automatic Humidifiers

The world's first computer-equipped, completely automatic humidifiers.

Aprilaire® High Efficiency Air Cleaners

Delivers the cleanest, healthiest air ever available from a whole-house air cleaner.

Aprilaire® Energy Recovery Ventilators

Your best value for a constant, controlled supply of fresh air with energy-recovery.

Aprilaire® Zone Control Systems

The most reliable way to achieve temperature control in every area of your home.

Aprilaire® Electronic Thermostats

Ultra-thin, easy-to-use digital, programmable, and communicating controls featuring pinpoint accuracy.



RESEARCH PRODUCTS CORPORATION

P.O. BOX 1467 • MADISON, WI 53701-1467