

SELF REGULATING FRESH AIR INLET FOR INDOOR AIR QUALITY VENTILATION

The Airlet 200 is a fresh air inlet designed to supply make up air ventilation for bedrooms and living areas, and is not intended to supply combustion air for fireplaces or large exhaust fans, such as range hoods. The Airlet 200 is compatible with zonal electric, radiant and hydronic heating systems. It must not be used with forced air heating systems, unless return registers are provided in each room in which an Airlet 200 is installed. This is to prevent exfiltration through the inlet when the forced air system is operating and doors are closed between rooms.

For make up air products specifically engineered for use with forced air heating systems, request an ALDES MAK from your supplier.

GENERAL NOTES AND SUGGESTIONS

Best results will be obtained in homes with tight air-vapor retarders, and continuous central exhaust from bathrooms, kitchen and laundry.

The goal is to achieve a home with slight negative pressure, to avoid exfiltration into the walls and attic. Install one fresh air inlet in each bedroom, and living/dining room area(s). *Inlets should not be installed in kitchens, bathrooms or laundry areas.* These areas should be exhaust points to a central exhaust system.

When placed high on exterior walls, drafts from the inlet should not be noticeable. The interior fixture has louvers to direct the airflow upwards where it quickly mixes with warmer air near the ceiling.

INSTALLATION INSTRUCTIONS

TOOLS REQUIRED

- 5-1/4" diameter hole saw,
Keyhole saw, saber saw or router
- Drywall knife
- Philips No.1 screwdriver
- Silicone or exterior butyl caulk

1. ON FLAT SIDING, OR SIDING WITH MINIMUM SIX INCH EXPOSURE

1.1 Locate the position of the inlet on the exterior with reference to the interior. The inlet on the interior should be within 12 inches of the ceiling, but not closer than 6 inches to the ceiling.

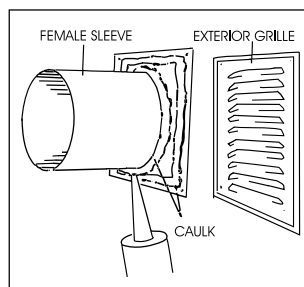

1) Some jurisdictions/utilities may have different requirements. Consult your code official/utility representative.

1.2 Using the appropriate hole cutting tool, cut a 5-1/8" diameter hole through the siding, sheathing, insulation and interior wall surface. Be careful to properly align the holes on the interior surface with the exterior.

CAUTION: Avoid cutting through any vertical framing members, pipes or electrical wiring.

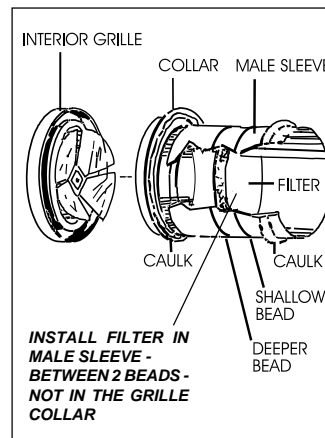

INSTALL FILTER IN MALE SLEEVE - BETWEEN 2 BEADS - NOT IN THE GRILLE COLLAR

1.3 Apply a 1/4 inch bead of caulk (silicone or butyl caulk is recommended) on the interior side of the square flange within 1/4 inch of its edges, and its connection with the cylindrical sleeve. These precautions are necessary in order to avoid infiltration of rain leakage or water behind the flange.

1.4 Insert the outer sleeve with the square flange through the siding

toward the interior.

1.5 Attach the exterior grille with mesh to the square flange and secure to the siding with the screws provided.

NOTE 1: The aluminum exterior grille may be painted with latex acrylic paint, after cleaning with a mild acid wash, such as vinegar. The white grille may be painted with an oil base paint if desired, though several coats may be necessary to obtain good results.

NOTE 2: If the siding is painted after installation of the exterior grille, take precautions to avoid paint clogging the mesh screen of the grille.

1.6 To install the interior half of the sleeve, first fit the plastic collar to the male sleeve with the two concave beads. Note that one bead is deeper than the other. The deeper bead must be oriented close to the plastic collar. Install the filter between the two beads. This should be a snug friction fit. (In the event of wind-driven rain entering the inlet, the filter can block further penetration, and the accumulating water can drain over the shallow bead to the exterior.)

Apply a generous bead of caulk to the concave beads. In addition, apply a small caulk bead to the flange of the plastic collar, to make an airtight

seal with the drywall surface. Then insert this assembly into the already-in-place female sleeve, and press firmly against the drywall. Wipe off any excess caulk from the circumference of the plastic collar.

1.7 Insert the plastic grille with the flow control element onto the plastic collar, with the louvers oriented to direct the airflow upward.

2. ON LAP SIDING WITH LESS THAN SIX INCH EXPOSURE

The procedure is the same, except it may be necessary to provide a mounting plate for fixtures, or **use a J-flashing** to accommodate the exterior flange and grille.

MAINTENANCE The only maintenance required is periodic cleaning of the filter and the interior grille. Occasionally, the mesh screen on the exterior grille may need to be cleared of insects and dust. **The part number for replacement filters is 23 026.**

Engineered Ventilation for Indoor Air Quality

INSTALLATION EXAMPLES

**INSTALLATION ON SIDING
(E.G. STUCCO, T1-11, etc.)**

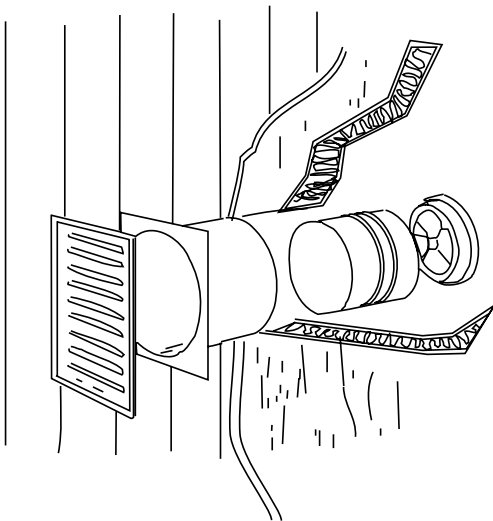

INSTALLATION WITH STUCCO SUB-PLATE

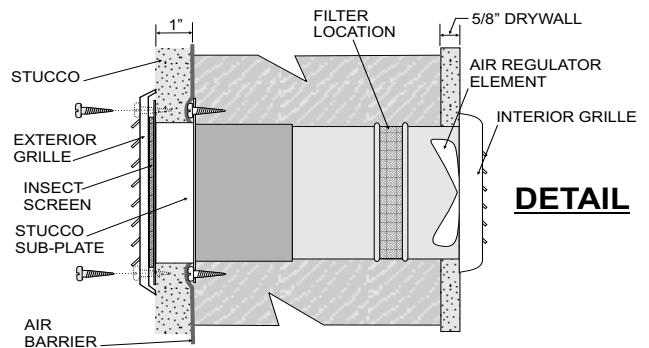
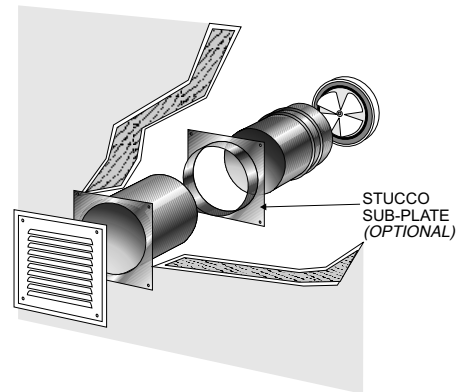

ACCESSORIES

**ARBORFOR
HOLESAW
PART#11 601**

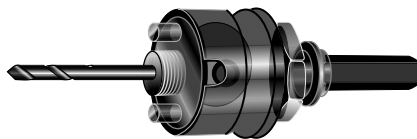

5-1/4\"/>

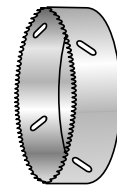

4537 NORTHGATE COURT
SARASOTA, FL 34234 -2124 USA
TEL: 941-351-3441
FAX: 941-351-3441
www.americanaldes.com
e-mail: info@aldes-us.com

