

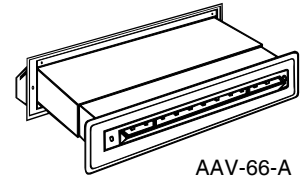

## SELF REGULATING FRESH AIR INLET FOR INDOOR AIR QUALITY VENTILATION



AAV-66-A  
Rev.8/06

The Airlet 100 is a fresh air inlet designed to supply make up air ventilation for bedrooms and living areas, and is not intended to supply combustion air for fireplaces or makeup air for large exhaust fans, such as range hoods.

The Airlet 100 is compatible with zonal electric, radiant and hydronic heating systems. It must not be used with forced air heating systems, unless return registers are provided in each room in which an Airlet 100 is installed. This is to prevent exfiltration through the inlet when the forced air system is operating and doors are closed between rooms.

For make up air products specifically engineered for use with forced air heating systems, request an ALDES MAK from your supplier.

### GENERAL NOTES AND SUGGESTIONS

Best results will be obtained in homes with tight air-vapor retarders, and continuous central exhaust from bathrooms, kitchen and laundry.

The goal is to achieve a home with slight negative pressure, to avoid exfiltration into the walls and attic. Install one fresh air inlet in each bedroom, and living/dining room area(s)<sup>1</sup>. *Inlets should not be installed in kitchens, bathrooms or laundry areas.* These areas should be exhaust points to a central exhaust system. When placed high on exterior walls, drafts from the inlet should not be noticeable. The interior fixture produces a thin ribbon of fresh air deflected upwards, which quickly mixes with the warmer air near the ceiling.

### INSTALLATION INSTRUCTIONS

#### TOOLS REQUIRED

- Saber saw or router
- Drywall knife
- Philips No. 1 screwdriver
- Silicone or exterior butyl caulk

#### WOOD FRAME WALL APPLICATIONS

1. Locate air inlets high on exterior walls in bedrooms, living/dining/family room areas. Avoid placing inlets closer than 6" to the ceiling, or condensation may occur on the ceiling near the inlet in cold weather. The inlet may

also be installed near baseboard heating.

2. The metal sleeves may be installed either:
  - During the framing stage - **after the exterior siding is applied, but before insulation and interior dry wall is completed.**
  - After all finish materials are applied.

#### 2.1 INSTALLING BEFORE DRYWALL

**2.1.1** First locate the studs, then mark the opening on the siding. **Avoid stud spaces with plumbing or electrical wires.** Cut the opening so that one side is flush with a stud. Using a reciprocating saw, cut through the siding and sheathing and remove or dislodge the insulation. Preserve the insulation for replacement around the sleeve.

**2.1.2** From the inside, install blocking between the studs either above or below the opening cut through the siding. *Install the blocking with a slight slope downward to the exterior (1/4" per foot slope is sufficient).* This slope will permit any water to drain to the exterior, should driving rain enter the sleeve.

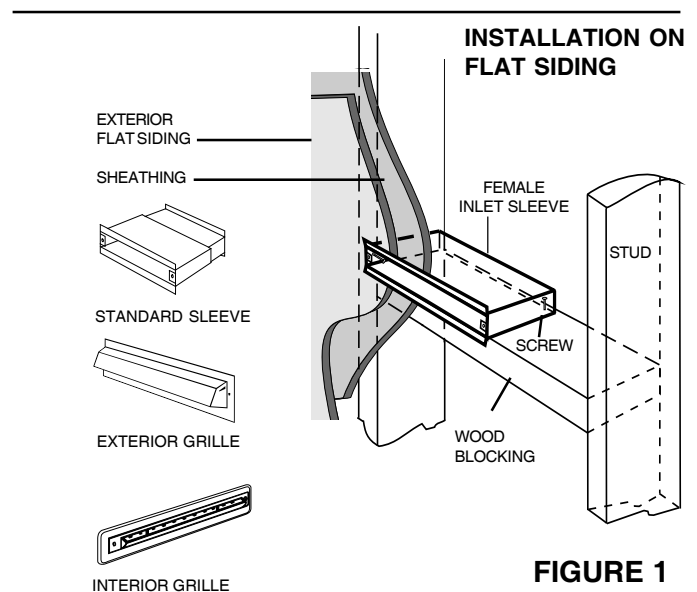

FIGURE 1

**2.1.3** Install the female part of the sleeve from the outside and secure it to the blocking with a **flat head** wood screw through the edge of the sleeve (drill a small hole in the sleeve as necessary). *See figure 1.*

<sup>1</sup> Some jurisdictions/utilities may have different requirements. Consult your code official/utility representative.

## 2.2 INSTALLATION AFTER DRYWALL IS INSTALLED

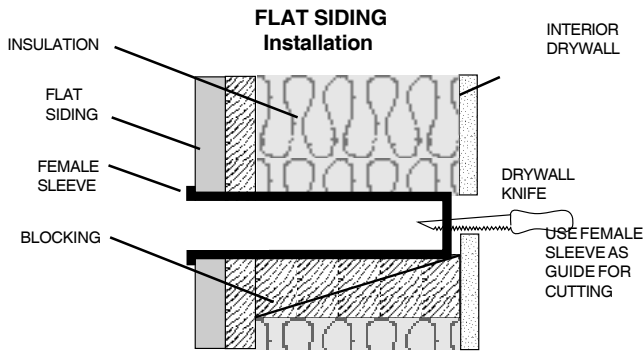

FIGURE 2

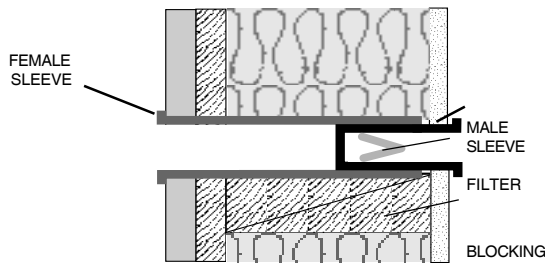

FIGURE 3

**NOTE:** Be careful to note the location of the inlet so that after insulation, vapor barrier and drywall is installed, the female inlet sleeve may be located to complete the installation.

**2.1.4** After the drywall has been installed, cut the opening for the male sleeve with a hand drywall knife, following the interior of the female sleeve as a guide. See figure 2.

**2.1.5** Insert the male sleeve, with the filter installed, into the female sleeve. See figure 3.

**2.1.6** Seal the exposed joints with silicone caulk:

- Between the sleeves.
- Between the siding and the sleeve.
- Between the drywall and the sleeve.

**2.1.7** Attach the exterior weather cap and the interior face plate to the sleeve with the screws provided.

**2.2.1** First locate the studs, then mark the rough opening on the siding. On bevel siding, locate the inlet so that the exterior cover plate will fall just below the lower edge of the siding. **Avoid stud spaces with plumbing or electrical wires.** Cut the opening so that one side is flush with a stud. Using a keyhole or reciprocating saw, cut through the siding and sheathing and remove or dislodge the insulation.

**2.2.2** Drill a small, 1/8" hole on the side of the female and male sleeves, within 1/2" of the edge of the sleeves, to permit driving a small nail or screw into the stud from the interior of the sleeve.

**2.2.3** Install the female sleeve through the siding and secure with a nail or screw to the stud. Using a long-handled screwdriver or awl, drive a hole through the drywall to locate the sleeve from the interior. Follow the procedures in 2.1.4 to 2.1.7.

### MASONRY WALL APPLICATIONS

The installation is similar to wood frame wall applications, except that the sleeves must be installed during the installation of brick or block. Provide solid blocking inside the sleeves to prevent deforming the metal sleeves. This blocking must be removed when the wall is finished.

### MAINTENANCE

The inlet is provided with a bug screen and a filter. These should be checked periodically and cleaned as necessary. The filter can be accessed from the interior of the home by removing the two screws securing the face plate to the metal sleeve. Remove the filter by grasping it at one corner and pulling it out at an angle. The filter may be washed or vacuumed. The bug screen on the exterior weather grille may be brushed or vacuumed at the same time. **The part number for replacement filters is 11 414.**

In extremely cold weather, some condensation may occur on the inlet, depending on the outside temperature and the indoor relative humidity. This should be an infrequent occurrence of short duration, occurring when there is a sudden drop in outside temperature. As the cold drier air enters and mixes with the interior air, the interior humidity should reduce sufficiently so that the condensation on the inlet disappears, and is not a cause of concern.

**AMERICAN  
ALDES**  
VENTILATION CORPORATION

4537 NORTHGATE COURT  
SARASOTA, FL 34234-2124, USA  
Tel: 941-351-3441  
Fax: 941-351-3442  
www.americanaldes.com  
e-mail: info@aldes-us.com

**IAQ  
VENTILATION  
HOTLINE  
800-255-7749  
ALDES**

#66-r8-06