

# SANTA FE ADVANCE - DUCT KIT ASSEMBLY

**DO NOT DRILL ANY PILOT HOLES INTO THE PLASTIC HOUSING!  
YOU MAY DAMAGE THE INTERNAL COMPONENTS!  
WHEN INSTALLING SCREWS, BE CAREFUL NOT TO STRIP. LIGHTLY TIGHTEN SCREWS!**

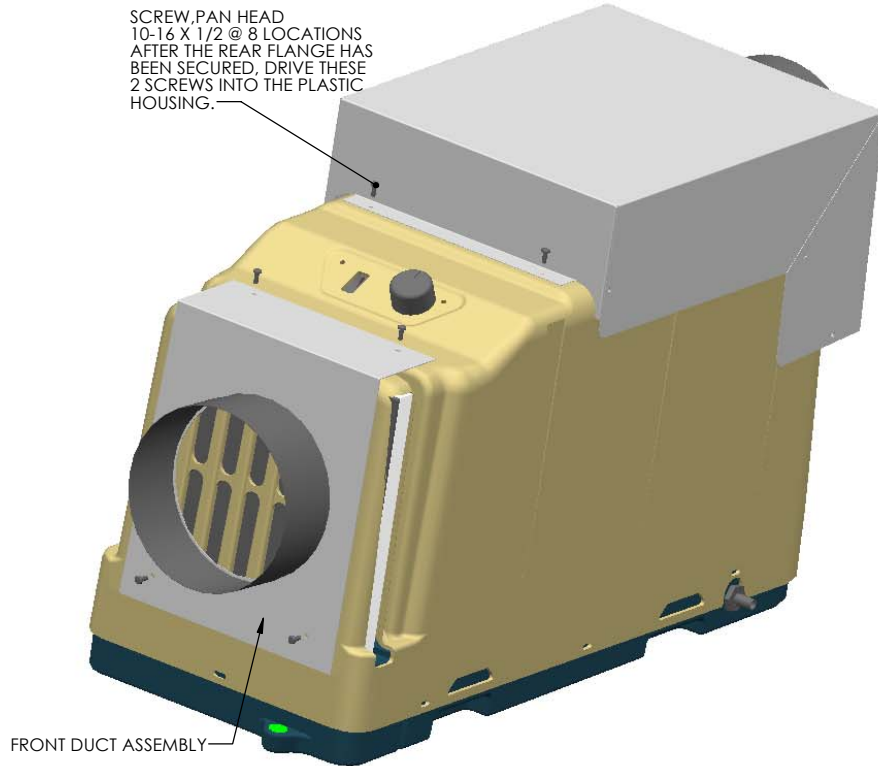
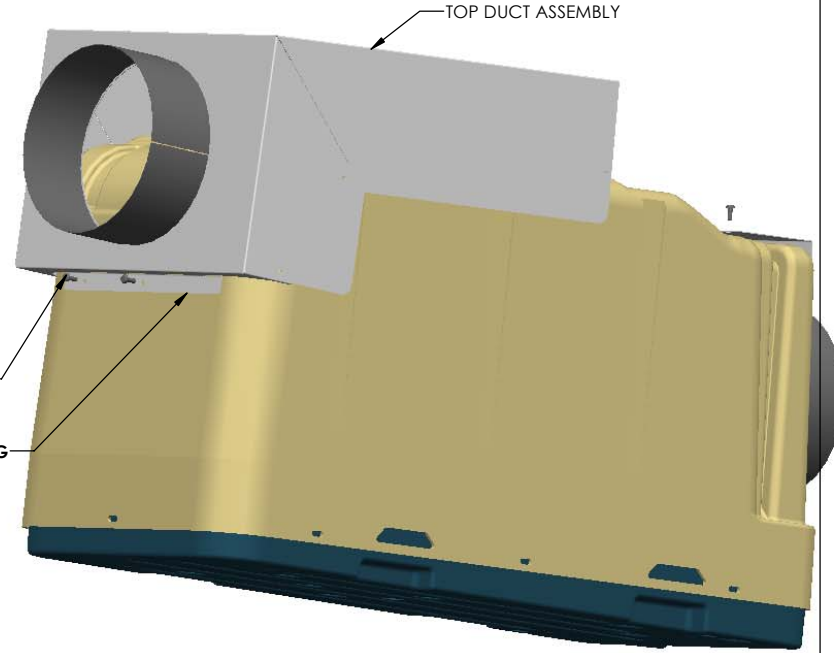

**FIGURE 1**

**STEP 1**

FRONT DUCT ASSEMBLY: REFER TO FIGURE 1

1. CHECK SEALING FOAM ON THE FRONT DUCT ASSEMBLY. ENSURE THAT NONE HAVE COME LOOSE.
2. PLACE FRONT DUCT ASSEMBLY ON THE INTAKE SIDE OF THE DEHUMIDIFIER
3. CENTER THE FRONT DUCT ASSEMBLY, ENSURE THAT THE SEALING FOAM MAKES CONTACT AROUND THE PLASTIC INTAKE GRILL SURFACE. SEALING FOAM SHOULD NOT COVER ANY OF THE INLET PORTION OF THE INTAKE GRILL.
4. **DO NOT DRILL PILOT HOLES FOR SCREWS. YOU WILL RISK POSSIBLY DAMAGING THE INTERNAL COMPONENTS** USING THE THRU HOLES PROVIDED IN THE FRONT DUCT ASSEMBLY, SCREW IN THE 10-16 X 1/2 SCREW DIRECTLY INTO THE PLASTIC HOUSING. BE CAREFUL NOT TO STRIP. LIGHTLY TIGHTEN SCREWS. DO THIS IN ALL FOUR THROUGH HOLE LOCATIONS.



**FIGURE 2**

**STEP 2**

TOP DUCT ASSEMBLY: REFER TO FIGURES 1 & 2.

1. CHECK SEALING FOAM ON THE TOP DUCT ASSEMBLY. ENSURE THAT NONE HAVE COME LOOSE.
2. PLACE TOP DUCT ASSEMBLY ON THE EXHAUST SIDE OF THE DEHUMIDIFIER. ENSURE THAT THE TOP DUCT ASSEMBLY COVERS ALL THE LOUVERS LOCATED ON THE TOP OF THE PLASTIC HOUSING.
3. CENTER THE TOP DUCT ASSEMBLY, ENSURE THAT THE SEALING FOAM MAKES CONTACT AROUND THE PLASTIC SURFACES.
4. ENSURE THAT THE REAR FLANGE OF THE TOP DUCT ASSEMBLY, IS SEATED FLUSH AGAINST THE BACK OF THE PLASTIC HOUSING. SEE FIGURE 2.
5. **DO NOT DRILL PILOT HOLES FOR SCREWS. YOU WILL RISK POSSIBLY DAMAGING THE INTERNAL COMPONENTS** USING THE THRU HOLES PROVIDED IN THE TOP DUCT ASSEMBLY, SECURE BACK FLANGE OF THE TOP DUCT ASSEMBLY FIRST. DRIVE TWO 10-16 X 1/2 SCREWS DIRECTLY INTO THE PLASTIC HOUSING. BE CAREFUL NOT TO STRIP. LIGHTLY TIGHTEN SCREWS. AFTER THE BACK FLANGE HAS BEEN SECURED, DRIVE IN THE LAST TWO SCREWS (LOCATED ON THE TOP) INTO THE PLASTIC HOUSING USING THE SAME PROCEDURE.

**STEP 3**

1. START UNIT AND CHECK FOR ANY AIR LEAKS AROUND THE PERIMETER OF THE DUCTS.
2. IF ANY LEAKS ARE FOUND, SEAL LEAK WITH FOIL TAPE.

<small>Do not scale drawing. Dimensions and tolerances per ANSI 14.5-1975. All dimensions are before plating. Deburr holes and sharp edges .005/.015. Machined surfaces 1/32 RMS.</small> <small>All dimensions are in inches.</small> <small>This drawing is confidential and proprietary to Thermo-Stor LLC. It is loaned strictly on condition that the information will not be used for the benefit of any other entity.</small> <small>MATL:</small>	<small>Tolerances unless otherwise specified</small> Decimal 2 Places.....± .01 3 Places.....± .005 Fractional.....± 1/64 Angular.....± 1/2° Capacitance.....± 10% Resistance.....± 5% Welding.....± 1/8"	<b>Therma-Stor LLC</b>		<small>DESCRIPTION: INSTR MANUAL SANTA FE ADV. DUCT KIT ASSY</small>	
		PO Box 8050, Madison, WI 53708		<small>REV. PCH</small> 11728 <small>WCH</small>	<small>REV. PCH</small> <small>DATE</small>
		<small>SCALE</small> NONE	<small>DWN BY</small> DMC	<small>DATE</small> 7-29-05	<small>PART NUMBER</small>
		<small>APPR. BY</small> DMC	<small>DATE</small> 7-29-05	<small>CHE BY</small> DMC	<small>DATE</small> 7-29-05
					<b>4026053</b>