

## V8043A,E,F 5000 Series ZONE VALVES

### APPLICATION

These valves consist of a motorized actuator and valve assembly for controlling the flow of hot water to a heat exchanger such as a radiator, convector, finned baseboard radiator, or in-floor radiant coil for space temperature control. The V8043 5000 series valves provide two-position, straight through control of supply water at up to 300 psi operating pressure.

Quick Fit actuator provides easy snap on and off connection to the valve assembly.



Patent Pending

### SPECIFICATION

#### Actuator Electrical Rating:

24Vac 60 Hz, 0.30 A Current Draw,  
5 W, 7.2 VA maximum

#### Electrical Connection:

18" leads or screw terminal board

#### Auxiliary Switch Rating:

120V, 4.4A running, 26.4A Inrush (60 Hz);  
50 VA Pilot duty at 24 V.

#### Fluid Temperature:

Standard models (class F motor):  
200° F (93° C) Max.

#### Ambient Temperature:

125°F (52° C) Max.

#### Humidity Limits:

95% Relative Humidity, Non-condensing

#### Shipping and Storage Temperature:

-40°F to 150°F (-40°C to 65°C).

#### Atmosphere:

Non-corrosive, non explosive.

#### Maximum Soldering Temperature:

500°F (260°C). Rubber ball plug must be  
moved away from the seat for soldering.

#### Maximum System Pressure Rating:

300 psi (2000 kPa), PN20.

#### Flow Characteristics:

Quick opening for on-off application.  
Slow return for water hammer resist.

#### Maximum Close-off Rating (@ Flow Capacity Rating) :

20 psi (@ 3.5 Cv)  
8 psi (@ 8 Cv)

#### Actuator Materials:

Case:galvanized steel.  
Cover : zinc plated steel.  
Sector gear: Brass

#### Valve Material:

Body of forged brass; drive shaft stem of  
stainless steel; ball plug of Buna-N rubber;  
o-ring seals of EPDM rubber.

#### Service Medium:

Suitable for glycol/water mix up to 50:50  
use in closed hydronic systems. Not for  
use with oxygenated water, potable water  
or steam.

Use this valve in hydronic systems which  
do not contain dissolved oxygen in the  
system water. The dissolved oxygen,  
which is found in systems that have a  
frequent source of make-up water, causes  
the rubber plug inside the valve to  
deteriorate and eventually fail.

#### Approvals:

CSA C/US Certified to Canadian Standards  
Association and Underwriter's Laboratories  
Standards.

### MODELS

**V8043** (Straight through, Normally Closed)

V8043A: Leadwires

V8043E: Leadwires and End Switch

V8043F: Terminal Board and End Switch

## V4043, V8043 SWEAT COPPER CONNECTION MODELS 6

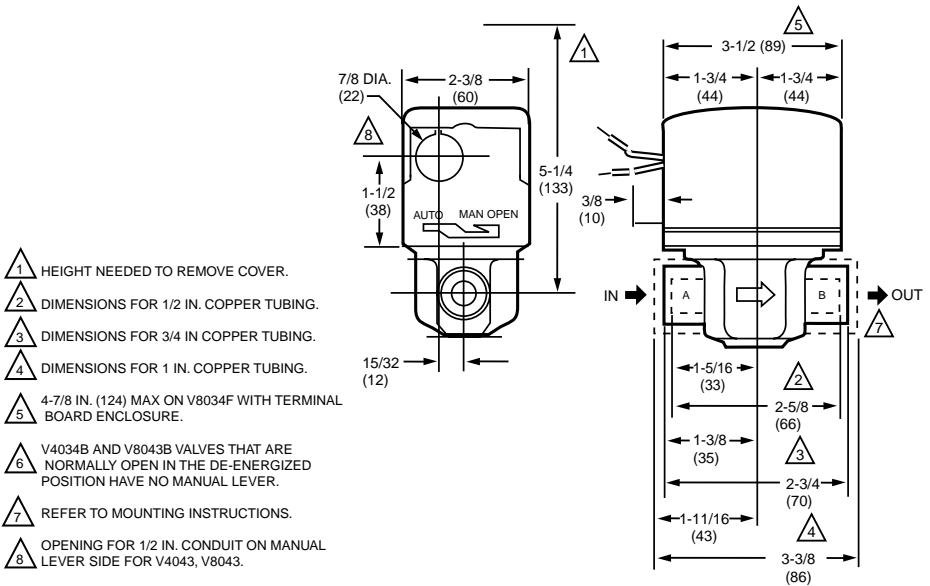

M10175.A4

**Fig. 1 - Mounting Dimensions in in. (mm in Brackets)**

### ! CAUTION

1. Disconnect power supply before connecting wiring to prevent electrical shock or equipment damage.
2. Normally it is not necessary to remove the actuator from the valve body during installation. If the valve must be disassembled, be certain that it is reassembled with the water flow in the direction of the arrow. Reversal of the actuator results in damage to the gear train.
3. On 24V systems, never jumper the valve coil terminals even temporarily. This can burn out the heat anticipator in the thermostat.

## INSTALLATION

### *When Installing this Product...*

1. Read these instructions carefully. Failure to follow them could damage the product or cause a hazardous condition.
2. Check the ratings given in the instructions and on the product to make sure the product is suitable for your application.

3. Installer must be a trained, experienced service technician.
4. After installation is complete, check out product operation as provided in these instructions.

### **Location**

Install the valve in an area with adequate clearance to:

- Move the manual opening lever on the side of the actuator
- Remove the actuator cover
- Wire the actuator
- Replace the actuator motor

The valve location should be in an area where the temperature does not exceed the maximum valve operating ambient temperature and fluid temperature.

### **Manual Lever**

The V8043 normally closed valves can be opened manually by moving the manual lever slowly and firmly to the MAN. OPEN position and pushing up to the stop. The stop permits the valve to be locked in the open position. The valve returns to automatic position when it is energized.

## MOUNTING

The valve can be mounted in any position on a vertical line. See Fig. 2. If the valve is mounted horizontally; the actuator must be even with or above the center line of the piping. Make sure to leave enough room above the actuator to remove the cover for servicing.

Mount the valve directly in the tube or pipe after the coil. **Make sure that the flow through the valve is in the direction indicated by the arrow stamped on the valve body.**

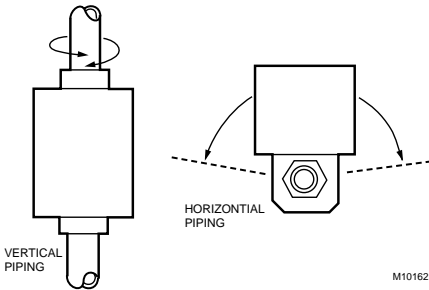

Fig. 2 - Mounting Positions

### Sweat Copper Models

1. Use new, properly reamed pipe, free from dents or corrosion.
2. Place the valve on the pipe. Set the manual opening lever to MAN. OPEN position before applying heat. This protects the plug inside the valve by removing it from the seat.
3. Sweat the joints, keeping the outer surface free from solder. DO NOT use silver solder because of the high melting temperature required.

### TO INSTALL A COMPLETE VALVE (V8043):

1. Disconnect power supply before connecting wiring to prevent electrical shock or equipment damage.
2. Install valve into pipe on the return side of the coil. (See Mounting Section.)
3. Make wiring connections to valve. (Refer to Wiring section for proper instructions.)
4. Inspect the valve installation to ensure that all connections and adjustments have been correctly made. Adjust the

thermostat or controller connected to the valve so that the valve runs through its cycle. Make sure the valve runs smoothly and positively from closed to open to closed again. (See Operation and Checkout Sections.)

### TO REMOVE THE ACTUATOR FROM THE VALVE BODY (See Fig. 3)

#### NOTE!

It is not necessary to drain the hydronic system if the valve body assembly remains in the pipe line.

1. Switch power supply OFF. Disconnect electrical leads carefully, noting the position and colour of each lead.
2. Place the manual lever in the MAN. OPEN position.
3. Remove actuator by fully depressing spring release button and lift it straight off of the body.

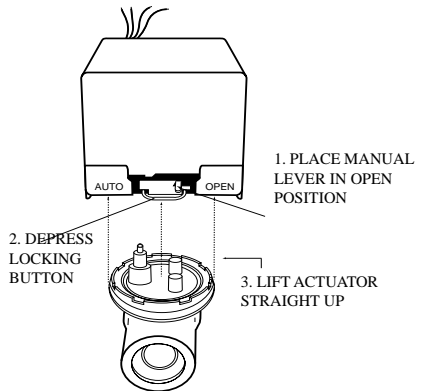

Fig. 3 - Removing Actuator from Valve Body

### TO INSTALL REPLACEMENT ACTUATOR ON THE VALVE BODY

1. **Align the parallel flat surfaces in double-D shaft of valve body with notch in side of body (i.e. 90° to water flow.) See Fig. 4.** This makes actuator attachment easier.
2. Wiring connections may be made either before or after actuator installed on valve body.
3. **Place the manual lever on the actuator in the MAN. OPEN position.**

4. Line up motor coupling to the parallel flat surfaces in double-D shaft of body and fit the actuator onto the valve body, ensuring that the shaft seats correctly. (See Fig. 5)
5. Snap actuator onto body by pressing down.
6. The manual lever may be released manually, but it is also automatically released when the valve is operated electrically.

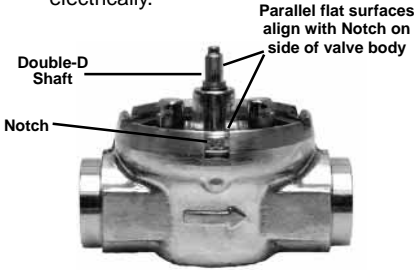

Fig. 4 - Shaft Position

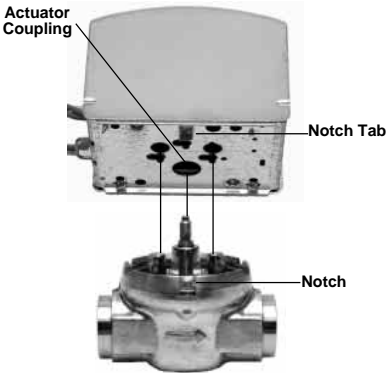

Fig. 5 - Installing Actuator

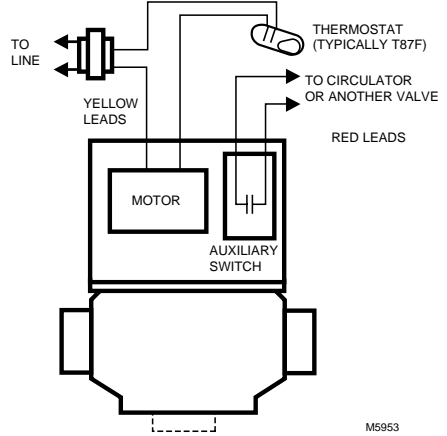
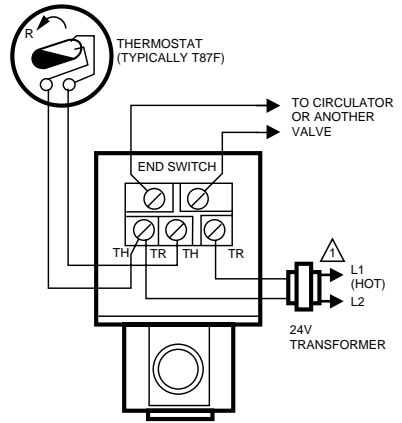

Fig. 6 - Typical wiring for V8043E, V8044E.



⚠ POWER SUPPLY. PROVIDE DISCONNECT MEANS AND OVERLOAD PROTECTION AS REQUIRED.

M5952

Fig. 7 - Typical wiring for V8043F.

## WIRING

Disconnect the power supply before connecting wiring to prevent electrical shock or equipment damage.

All wiring must comply with local codes and ordinances. Connections to the individual valves are shown in Fig. 6 and 7. See Fig. 8 through 14 for typical hookups.

If replacing a Taco, Dole, Flair or White Rodgers 3-wire valve with a 2-wire V8043E or F, see Fig. 15 through 27. Check that the pressure rating of the new valve is appropriate for the application.

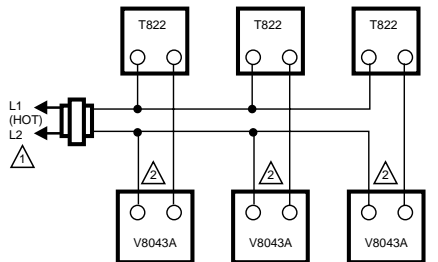

⚠ POWER SUPPLY. PROVIDE DISCONNECT MEANS AND OVERLOAD PROTECTION AS REQUIRED.

⚠ CONNECT V8043A BLACK LEADWIRE TO THERMOSTAT.

M10168

Fig. 8 - T822 Thermostat, V8043A valve hookup.

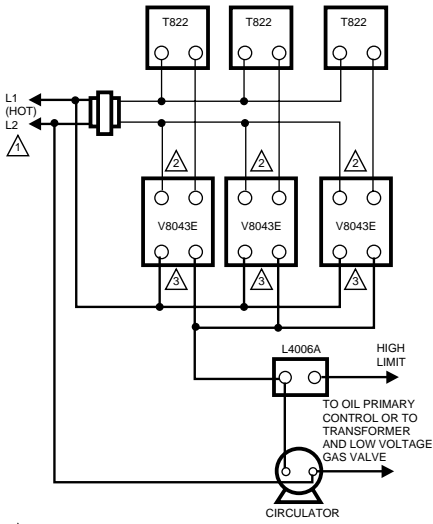

- ⚠ POWER SUPPLY. PROVIDE DISCONNECT MEANS AND OVERLOAD PROTECTION AS REQUIRED.
- ⚠ CONNECT V8043E YELLOW LEADWIRE TO THERMOSTAT.
- ⚠ CONNECT V8043E RED LEADWIRES TO L1 (HOT) LINE AND PRIMARY CONTROL.

M10169

Fig. 9 - T822, V8043E zone hookup for gas or oil. No domestic hot water.

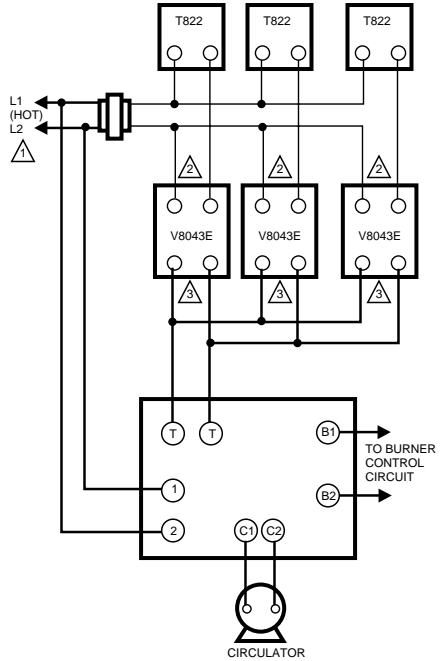

- ⚠ POWER SUPPLY. PROVIDE DISCONNECT MEANS AND OVERLOAD PROTECTION AS REQUIRED.
- ⚠ CONNECT V8043E YELLOW LEADWIRE TO THERMOSTAT.
- ⚠ CONNECT V8043E RED LEADWIRES TO AQUASTAT®.

M10170

Fig. 10 - T822, V8043E zone hookup for gas or oil with or without domestic hot water. Without domestic hot water, use L8148J for gas, and L8148A for oil. With domestic hot water, use L8124E for gas, and L8124A or C for oil.

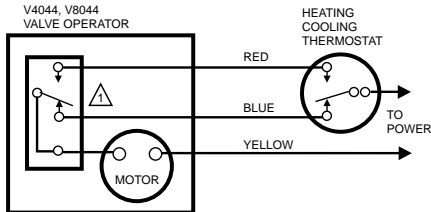

- ⚠ AQUASTAT® CHANGEOVER CONTROL SWITCHES TO HEATING (RED) AT FLUID TEMPERATURE OF 85°F (29°C) MAX TO COOLING (BLUE) AT FLUID TEMPERATURE OF 60°F (18°C) MIN.

M10171

Fig. 11 - Wiring diagram for V4244 and V8244 with Aquastat® changeover control.

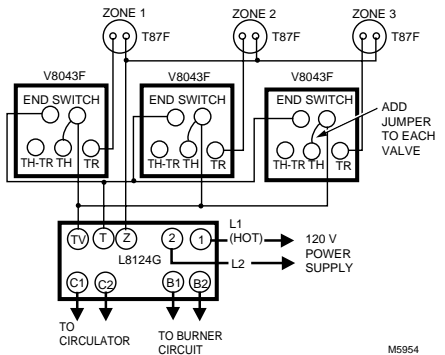

Fig. 12 - Typical 3-zone system. Use an AT87A Transformer to power up to five more zone valves.

M5954

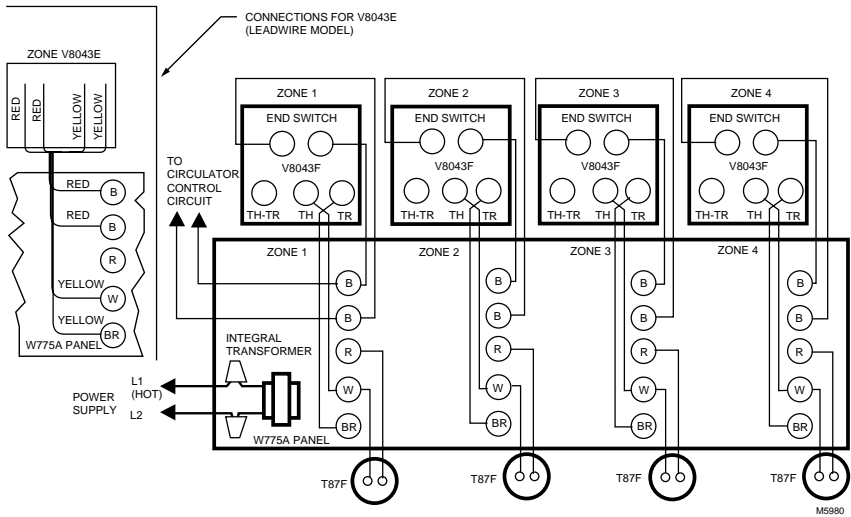
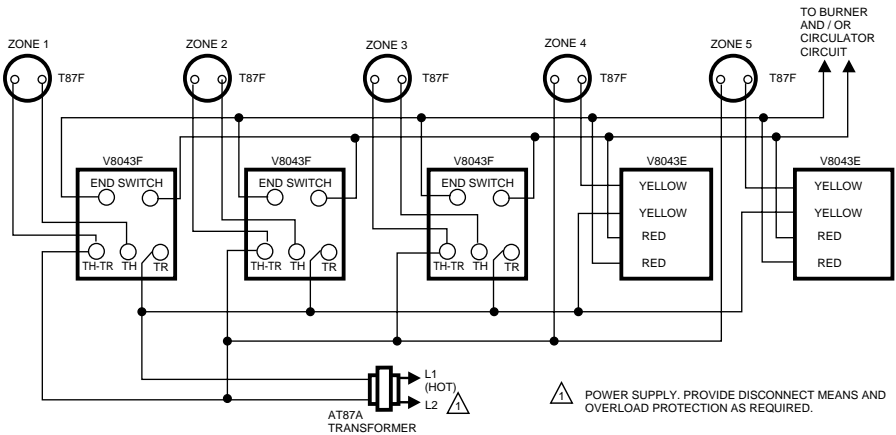

Fig. 13 - Typical 4-zone system. Use an additional W775A to power up to four more zone valves.



NOTE: IF CODE PERMITS, V8043E AND V8043F CAN BE USED INTERCHANGEABLY WHEN WIRED AS SHOWN.

Fig. 14 - Typical 5-zone system. Use an AT87A Transformer to power up to five more zone valves.

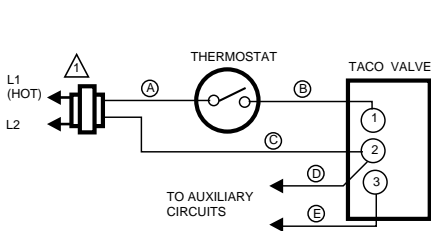

Fig. 15 - Existing Taco system. (Wires are identified with letters to correspond with wires in Fig. 16 and 17.)

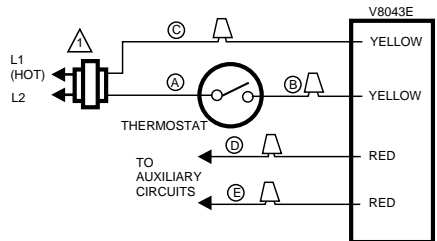
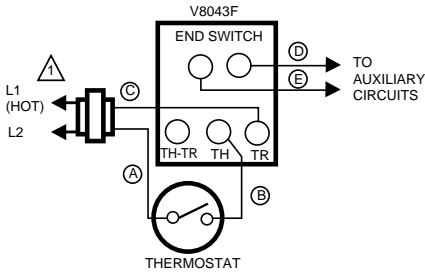
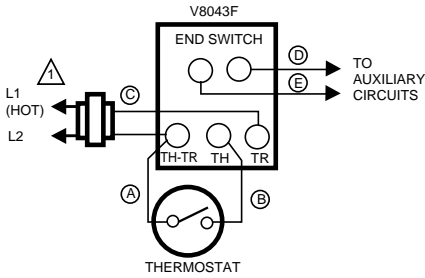

Fig. 16 - Wiring Honeywell V8043E to Taco System (Wires are identified with letters to correspond with wires in Fig. 15.)



⚠️ POWER SUPPLY. PROVIDE DISCONNECT MEANS AND OVERLOAD PROTECTION AS REQUIRED.

M5977

**Fig. 17 - Wiring Honeywell V8043F to Taco System (two options).** (Wires are identified with letters to correspond with wires in Fig. 15.)

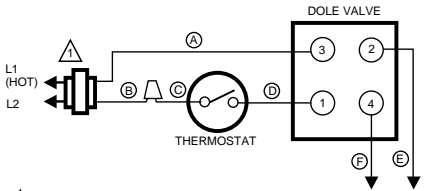

⚠️ POWER SUPPLY. PROVIDE DISCONNECT MEANS AND OVERLOAD PROTECTION AS REQUIRED.

M5977

**Fig. 18 - Existing Dole System.** (Wires are identified with letters to correspond with wires in Fig. 19 and 20.)

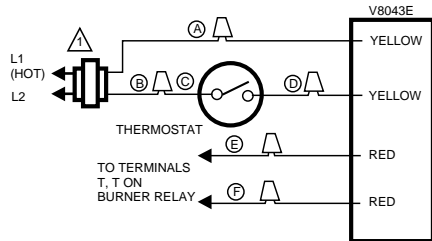

⚠️ POWER SUPPLY. PROVIDE DISCONNECT MEANS AND OVERLOAD PROTECTION AS REQUIRED.

M5965

**Fig. 19 - Wiring Honeywell V8043E to Dole System.** (Wires are identified with letters to correspond with wires in Fig. 18.)

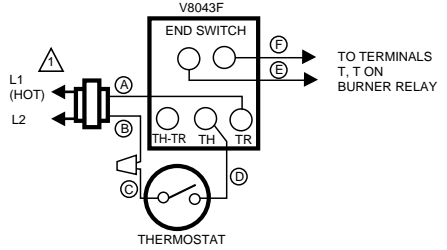
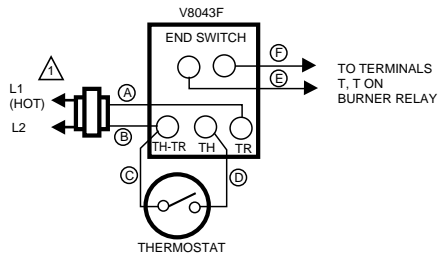

⚠️ POWER SUPPLY. PROVIDE DISCONNECT MEANS AND OVERLOAD PROTECTION AS REQUIRED.

M5966

**Fig.20 - Wiring Honeywell V8043F to Dole System (two options).** (Wires are identified with letters to correspond with wires in Fig. 18.)

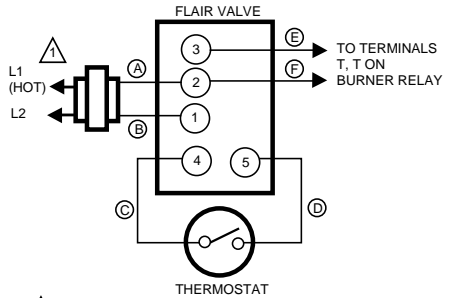

⚠️ POWER SUPPLY. PROVIDE DISCONNECT MEANS AND OVERLOAD PROTECTION AS REQUIRED.

M5978

**Fig. 21 - Existing Flair System.** (Wires are identified with letters to correspond with wires in Fig. 22 and 23.)

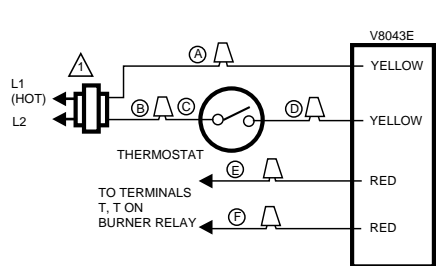

⚠️ POWER SUPPLY. PROVIDE DISCONNECT MEANS AND OVERLOAD PROTECTION AS REQUIRED.

M5965

**Fig. 22 - Wiring Honeywell V8043F to Flair System.** (Wires are identified with letters to correspond with wires in Fig. 21.)

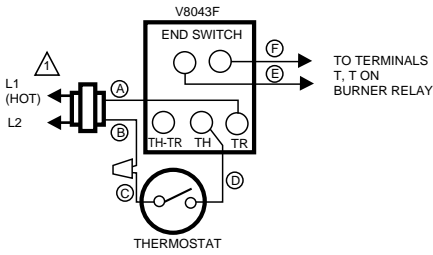
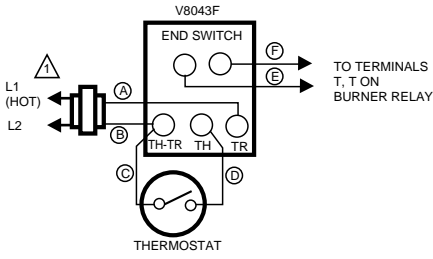

△ POWER SUPPLY. PROVIDE DISCONNECT MEANS AND OVERLOAD PROTECTION AS REQUIRED. M5966  
**Fig. 23 - Wiring Honeywell V8043F to Flair System (two options).**  
 (Wires are identified with letters to correspond with wires in Fig. 21.)

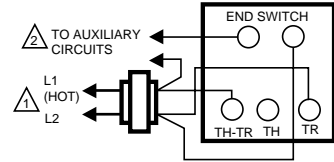
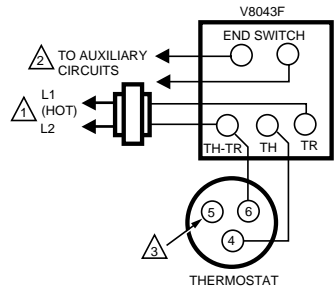

△ POWER SUPPLY. PROVIDE DISCONNECT MEANS AND OVERLOAD PROTECTION AS REQUIRED.  
 △ IF TRANSFORMER SUPPLIES POWER TO AUXILIARY CIRCUIT, WIRE AUXILIARY CIRCUIT AS SHOWN IN LOWER DIAGRAM.  
 △ TAPE UNUSED END AND TUCK INTO HOLE. M5713

**Fig. 26 - Wiring Honeywell V8043F to White-Rodgers System (one option).**

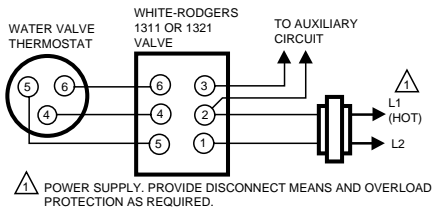

△ POWER SUPPLY. PROVIDE DISCONNECT MEANS AND OVERLOAD PROTECTION AS REQUIRED. M5711

**Fig. 24 - Existing White-Rodgers System.**

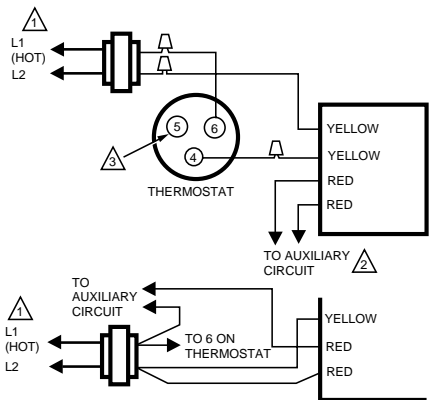

△ POWER SUPPLY. PROVIDE DISCONNECT MEANS AND OVERLOAD PROTECTION AS REQUIRED.  
 △ IF TRANSFORMER SUPPLIES POWER TO AUXILIARY CIRCUIT, WIRE AUXILIARY CIRCUIT AS SHOWN IN LOWER DIAGRAM.  
 △ TAPE UNUSED END AND TUCK INTO HOLE. M5712

**Fig. 25 - Wiring Honeywell V8243E to White-Rodgers System.**

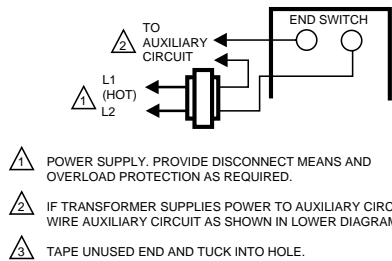
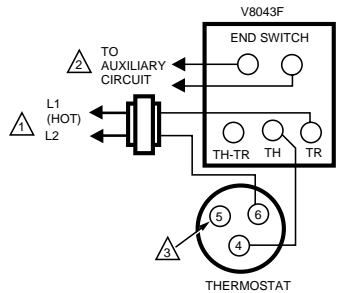

△ POWER SUPPLY. PROVIDE DISCONNECT MEANS AND OVERLOAD PROTECTION AS REQUIRED.  
 △ IF TRANSFORMER SUPPLIES POWER TO AUXILIARY CIRCUIT, WIRE AUXILIARY CIRCUIT AS SHOWN IN LOWER DIAGRAM.  
 △ TAPE UNUSED END AND TUCK INTO HOLE. M5714

**Fig. 27 - Wiring Honeywell V8043F to White-Rodgers System (alternate option).**

## OPERATION



### CAUTION

On 24V systems, never jumper the valve coil terminals even temporarily. This can burn out the heat anticipator in the thermostat.

### Automatic Operation

On a call for heat by the zone thermostat, the valve opens and its auxiliary switch contacts make, closing the circuit to the system circulator. In a multizone system with all the valve auxiliary switches wired in parallel, any zone calling for heat can operate the circulator. When the call for heat ends, the valve closes by integral spring return. The auxiliary switch contacts break the circulator circuit.

### Manual Operation

The motorized valve can be opened manually by lifting the manual opening lever over the stop and pushing slowly and firmly to the MAN. OPEN position. The stop permits the valve to be locked in the open position. The valve returns to automatic position when the valve is energized.

### Normally Closed Models

With the manual opener set to AUTO and the actuator energized, the valve is opened as shown in Fig. 28A. When the actuator is de-energized, a spring-return mechanism drives the valve to the closed position as shown in Fig. 28B. The valve can also be opened with no electrical power by moving the manual opening lever over the stop and pushing slowly and firmly to the MAN. OPEN position. The stop permits the valve to be locked in the open position.

The valve returns to the automatic position when the valve is energized.

**Auxiliary switch is not energized when the valve is manually opened.**

NOTE: Flow direction arrow is stamped on the valve body indicating flow direction from Inlet Port A to Outlet Port B.

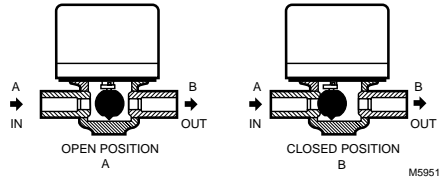

Fig. 28 - V8043 operation for normally closed valve.

## CHECKOUT

1. Raise the setpoint on the zone thermostat above the room temperature to initiate a call for heat.
2. Observe all control devices—the valve should open and the auxiliary switch should make the circuit to the circulator or other valve at the end of the opening stroke.
3. Lower the setpoint on the zone thermostat to below the room temperature.
4. Observe the control devices. The valve should close and the auxiliary equipment should stop.

## SERVICE

This valve should be serviced by a trained, experienced service technician.

1. If the valve is leaking, drain the system and check to see if the O-ring needs replacing.
2. If the gear train is damaged, replace the entire actuator assembly. See the Installation section. If the motor is burned out, replace the motor. See Replacement Parts list in the TRADELINE® Catalog.

NOTE: Honeywell zone valves are designed and tested for silent operation in properly designed and installed systems; however, water noises can occur as a result of excessive water velocity or piping noises can occur in high temperature (higher than 212°F (100°C) systems with insufficient water pressure. Valves are designed for normal cycling operations. Product life will be shortened if energized continuously.

**Honeywell**

---

**Automation & Control**  
Honeywell  
1985 Douglas Drive North  
Golden Valley  
MN 55422-3992

**In Canada**  
Honeywell Limited/Limitée  
35 Dynamic Drive  
Toronto, Ontario  
M1V 4Z9