



Quality and Reliability

Proven design using electrode technology perfected by Dri-Steem® a subsidiary of Research Products.

Easy to Install

Remote or duct mount with no additional accessories.

Easy to Maintain

No cleaning or scrubbing, simply remove canister and replace.

Dispersion and Absorption

Steam dispersion technology, ensures proper dispersion into the air, preventing condensation in duct.

No Accessories Required

Water filtration not needed even in most difficult conditions.

Control, dispersion tube, steam hose and drain tube included in the box.

Model 850 Fan Pack



Weight: 10 lbs

• 24 VAC • 60 Hz • 0.75 Amps

- The Model 850 Fan Pack marries with the Aprilaire Model 800 Steam Humidifier to provide comfortable humidity levels to homes without duct work.
- Quiet operation makes the Model 850 Fan Pack practically unnoticeable
- Designed to blend into a home's environment
- Easy install – Recessed into a wall and connects directly to the Model 800 Steam Humidifier.

Voltage	kW	Maximum steam capacity	Current draw (amps)	Humidifier unit operating weight
		gal/day	Amps	lbs
120V	1.4	11.5	11.5	23
208V	2.4	20.5	11.5	23
240V	2.8	23.3	11.5	23

- Water Hardness – 3 to 36 grain per gallon, water filtration not necessary
- Supply water pressure must be between 25 psi and 120 psi
- Drain water flushes with fresh inlet water

- Electrical draw 11.5 amps \pm 10%, use 12.7 amps when sizing circuit
- 208 or 240v, run two conductors plus neutral plus ground
- Canister replacement once per humidifier season under normal conditions. Unit will automatically notify when canister must be replaced.

MODEL 800 STEAM HUMIDIFIER

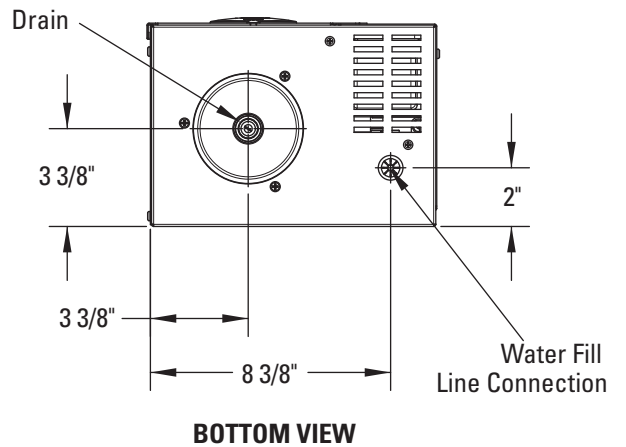
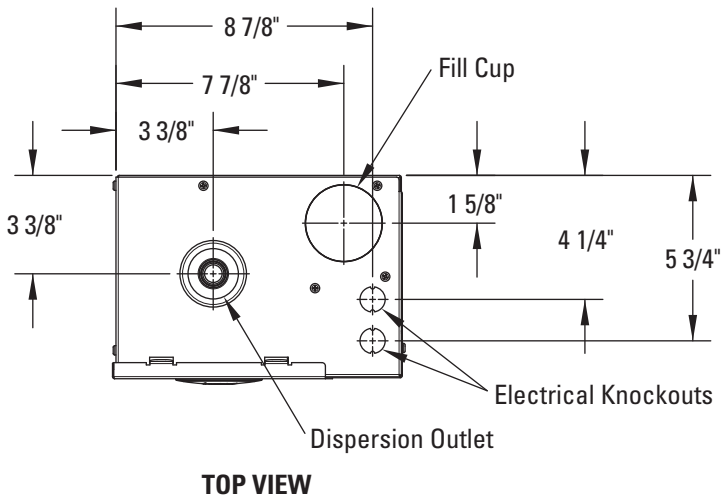
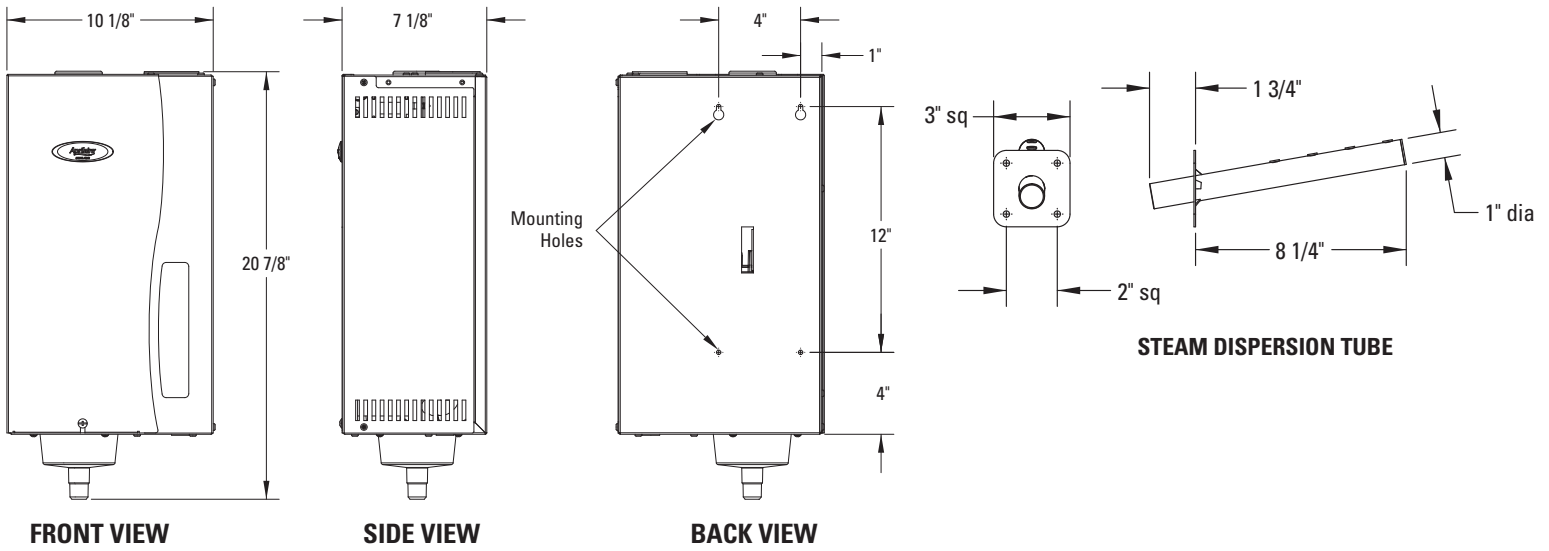

MODEL 850 FAN PACK

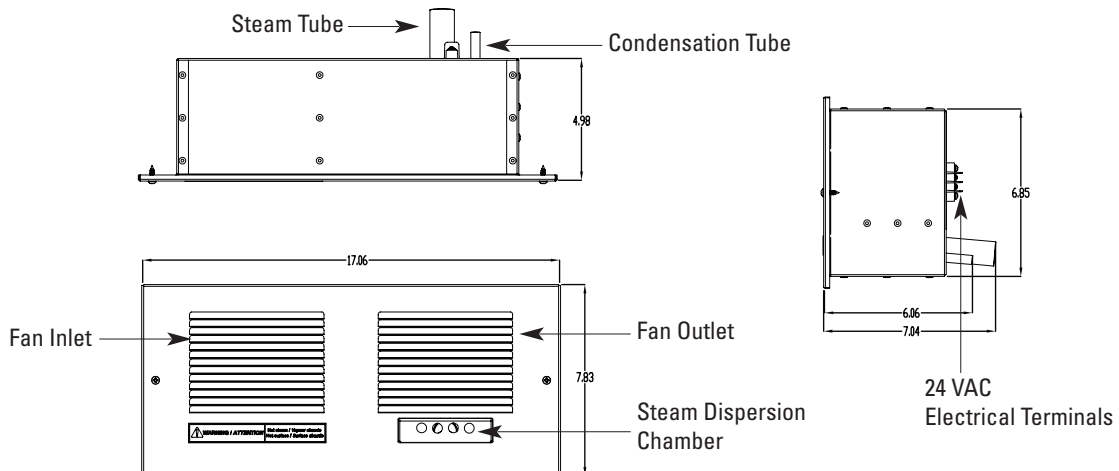

RESEARCH PRODUCTS RESERVES THE RIGHT TO CHANGE SPECIFICATIONS WITHOUT NOTICE.