

W8703A Damper Interface Module

INSTALLATION INSTRUCTIONS

APPLICATION

The W8703A Damper Interface Module (DIM) controls up to three conventional zone dampers when used with T8635L Microelectronic Communicating Programmable Thermostats and the W8635 Equipment Interface Module, Table 1. The W8703A uses Enviracom, a low-cost wired communications protocol.

Using the W8703A Damper Interface Module with up to three T8635L Microelectronic Communicating Programmable Thermostats and a W8635A,B Equipment Interface Module enables the following features:

- Time synchronization.
- Shared filter indication.

- Outdoor temperature display in all zones with only one C7089B Outdoor Temperature Sensor connected.
- Vacation Hold in all zones.
- Check LED in all zones (when used with the W8635B Equipment Interface Module for heat pumps).
- System switch setting automatically changes in all zones.
- Individual fan control in each zone.

NOTES:

- Up to three T8635 Thermostats can be controlled with the W8703A Damper Interface Module.
- Up to six zones can be controlled using two W8703A and up to nine zones can be controlled using three W8703A.

Table 1. W8703A Description.

Model	Application	Recommended Zone Dampers	Comments
W8703A	Controls up to three zone dampers.	Trol-A-Temp® Model AOBD or Trol-A-Temp® Model ARD or Trol-A-Temp® Model ZD	Use with T8635L Microelectronic Communicating Programmable Thermostat and W8635A,B Equipment Interface Modules.

Required Accessories

1. T8635L Microelectronic Communicating Programmable Thermostat.
2. W8635A Equipment Interface Module for up to 2H/2C conventional applications or W8635B Equipment Interface Module for up to 2H/1C heat pump applications.

3. Installer must be a trained, experienced service technician.
4. After installation is complete, check out product operation as provided in these instructions.
5. Follow local codes for installation and application.



CAUTION

Voltage Hazard.
Can cause electrical shock or equipment damage.
Disconnect power before beginning installation.

INSTALLATION

When Installing this Product . . .

1. Read these instructions carefully. Failure to follow them could damage the product or cause a hazardous condition.
2. Check the ratings given in the instructions and on the product to make sure the product is suitable for your application.

Location

Locate the W8703A in the equipment room near the HVAC equipment. See Fig 1.



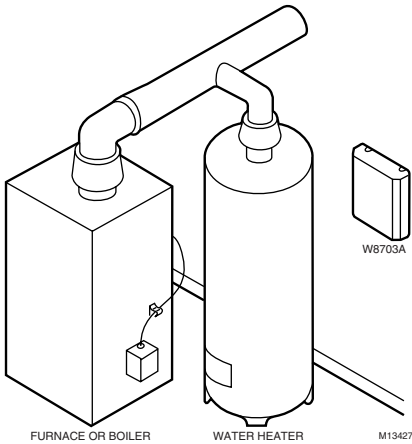

Fig. 1. Mounting W8703A on wall or duct.

Mounting



CAUTION

Mounting Location Hazard.
Mounting W8703A inside HVAC equipment can damage the DIM.
 Mount the W8703A only on the outside of HVAC equipment.

1. Remove the cover from the W8703A by pulling it from the center or the corners of the module.
2. Locate the two mounting holes. See Fig 1.
3. Position the W8703A on the wall or the cold air return.
4. Level the W8703A for appearance only; the device will function properly even when not level.
5. Use a pencil to mark the position of the mounting holes on the wall or cold air return.
6. Remove the W8703A from the wall or cold air return and drill 3/16 in. holes in the wall (if drywall) where marked. For firmer materials such as plaster or wood, drill 7/32 in. holes. See Fig. 2.
7. Gently tap the anchors (provided) into the holes until flush with the wall.
8. When mounting on the cold air return, drill a pilot hole where marked.
9. Reposition the W8703A over the holes.
10. Loosely insert the screws into the holes.
11. Tighten the screws.

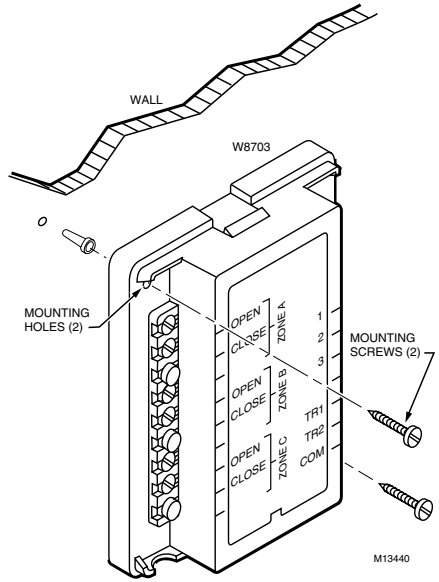

Fig. 2. Mounting W8703A Damper Interface Module.

WIRING



CAUTION

Voltage Hazard.
Can cause electrical shock or equipment damage.
 Disconnect power before beginning installation.

All wiring must comply with local codes and ordinances. Use the following steps:

1. Loosen the terminal screws on the W8703A and connect the system wires; see Fig. 3 and Table 2.
2. Securely tighten each terminal screw.

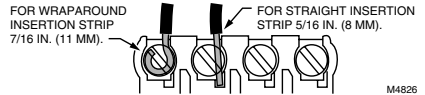

Fig. 3. Correct wiring technique.

Table 2. Terminal Designations

W8703A Terminal Designations		Function
1		To communications bus.
2		To communications bus.
3		To communications bus.
TR1		To external 24 Vac transformer – to power zone dampers. ^a
TR2		To external 24 Vac transformer – to power zone dampers. ^a
Zone A	Open	Connect to zone 1 zone damper. ^b
	Closed	
Zone B	Open	Connect to zone 2 zone damper. ^b
	Closed	
Zone C	Open	Connect to zone 3 zone damper. ^b
	Closed	

^a Transformer must be appropriately sized to supply power to total damper load (60 VA maximum).

^b 30 VA maximum damper load per zone.

- See Fig. 4 to wire the T8635L, W8635A and W8703A in forced air systems.
- See Fig. 5 and 6 to wire hydronic heat with V8043 zone valves.
- See Fig. 7-9 to wire hydronic heat with circulators.
- See Fig. 10 to wire hydronic heat with V8043 zone valves and an indirect water heater.
- See Fig. 11 to wire hydronic heat with time-out on an indirect water heater.
- Connect a 24 VAC transformer to the W8703. Connect HVAC system 24 VAC to the W8635. Provide disconnect means and overload protection as required.
- If the application is for 4-6 forced air zones, then connect an additional W8703 and a corresponding transformer. For 6-9 zones, then connect a third W8703 and a corresponding transformer. See SETTINGS for instructions on how to set the DIP switches on the W8703
- If the application is for 4-6 hydronic zones, connect an additional W8703 and a corresponding transformer. Wire the second W8703 COM terminal to terminal 4 on the R8222N1011, and terminal number 6 on the relay to zone 4-6 zone valves or circulator relays. For 7-9 hydronic zones use the normally open contacts on a 4PDT 4 pole relay in the same way for each of the three W8703 panels.

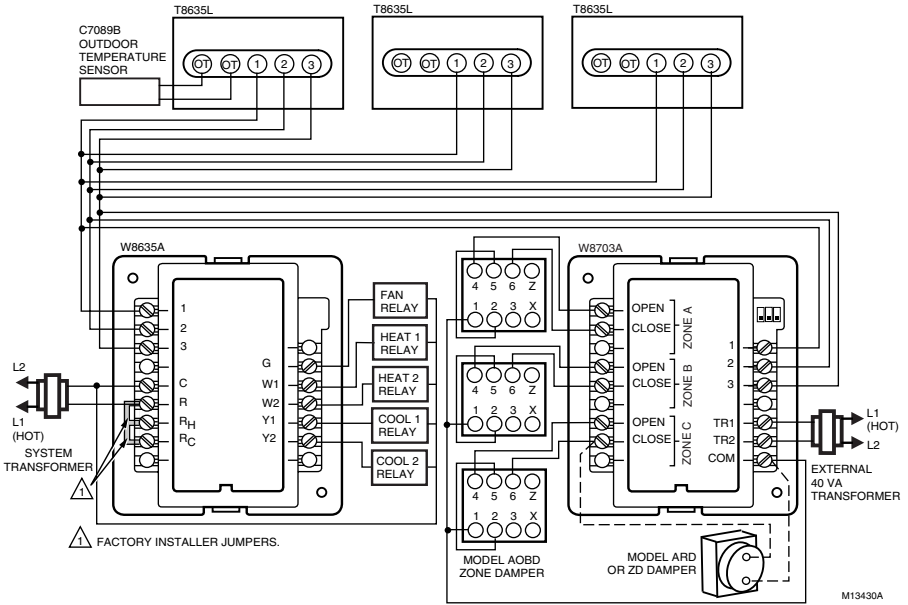

Fig. 4. T8635L/ W8703A/ W8635A wiring diagram.

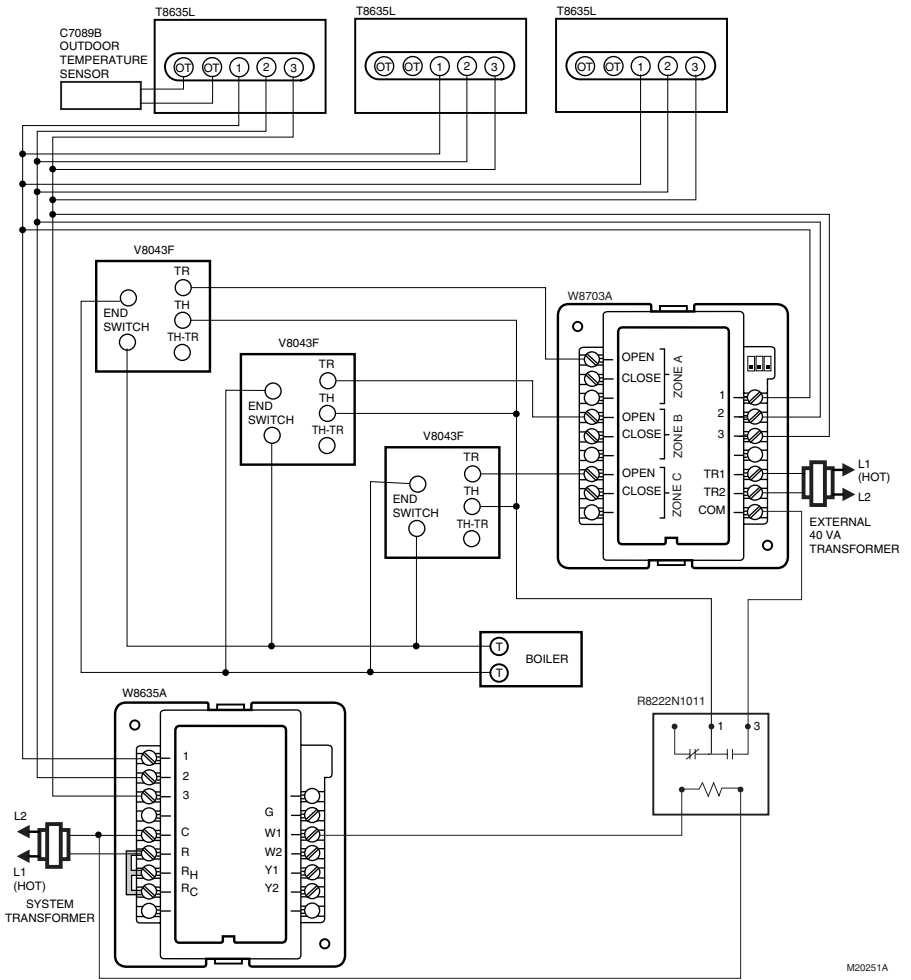

Fig. 5. Hydronic heat with V8043 zone valves and non-zoned air conditioning wiring diagram.

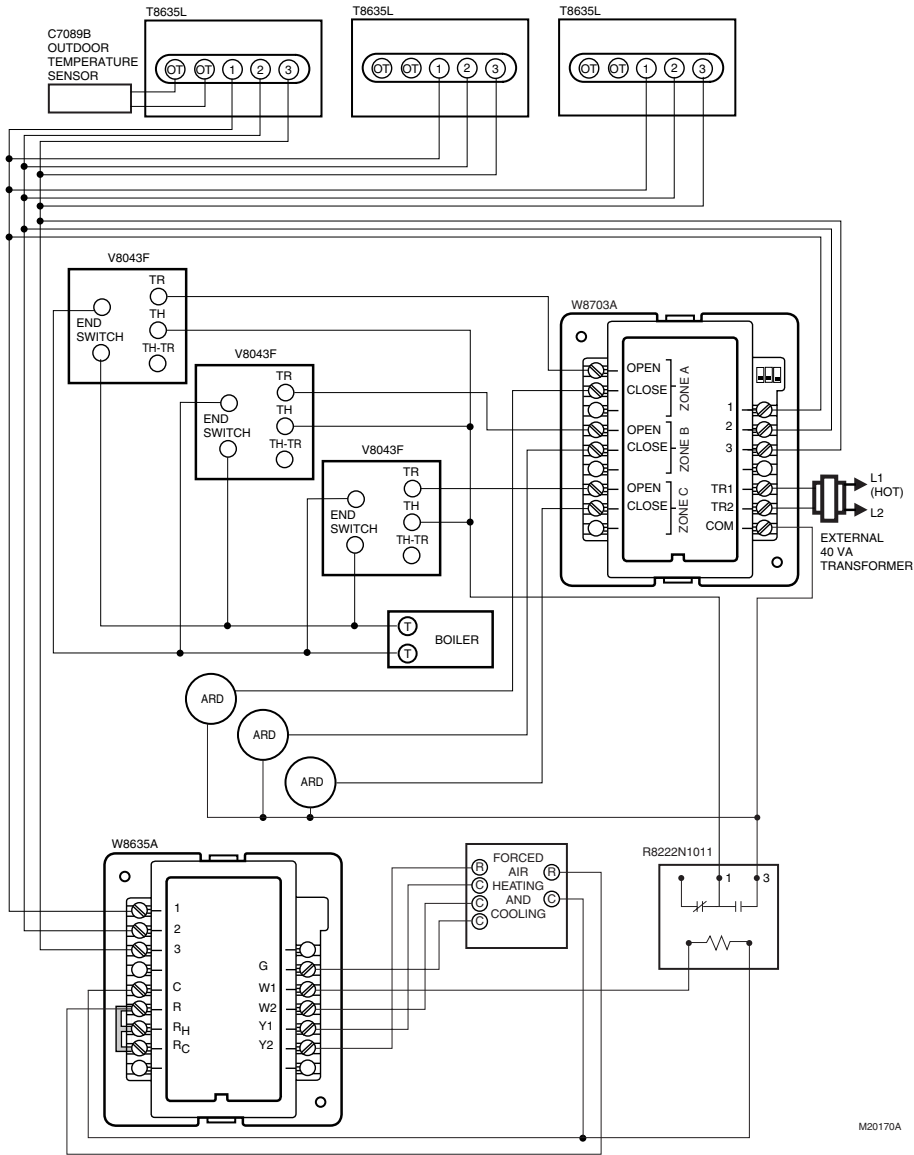

Fig. 6. Hydronic heat with V8043 zone valves and air conditioning with dampers wiring diagram.

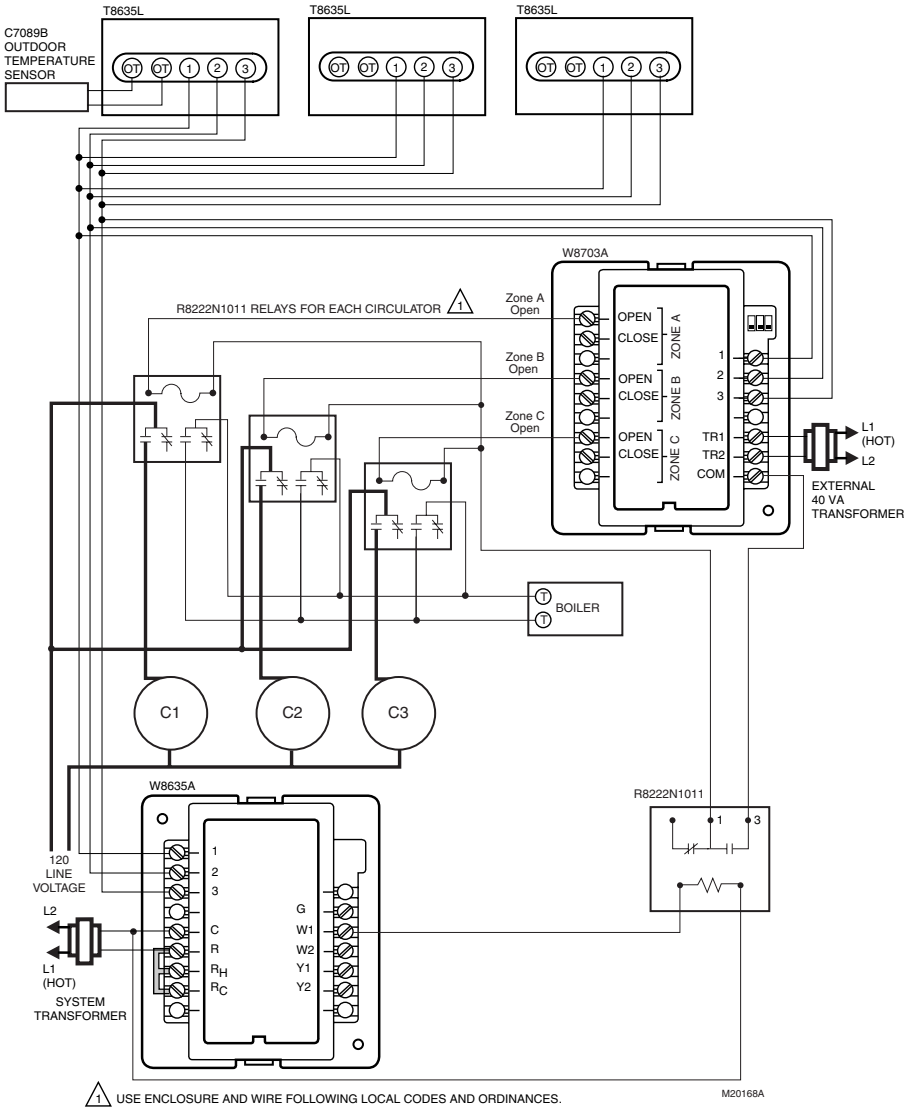

Fig. 7. Hydronic heat with circulator relays and no air conditioning wiring diagram.

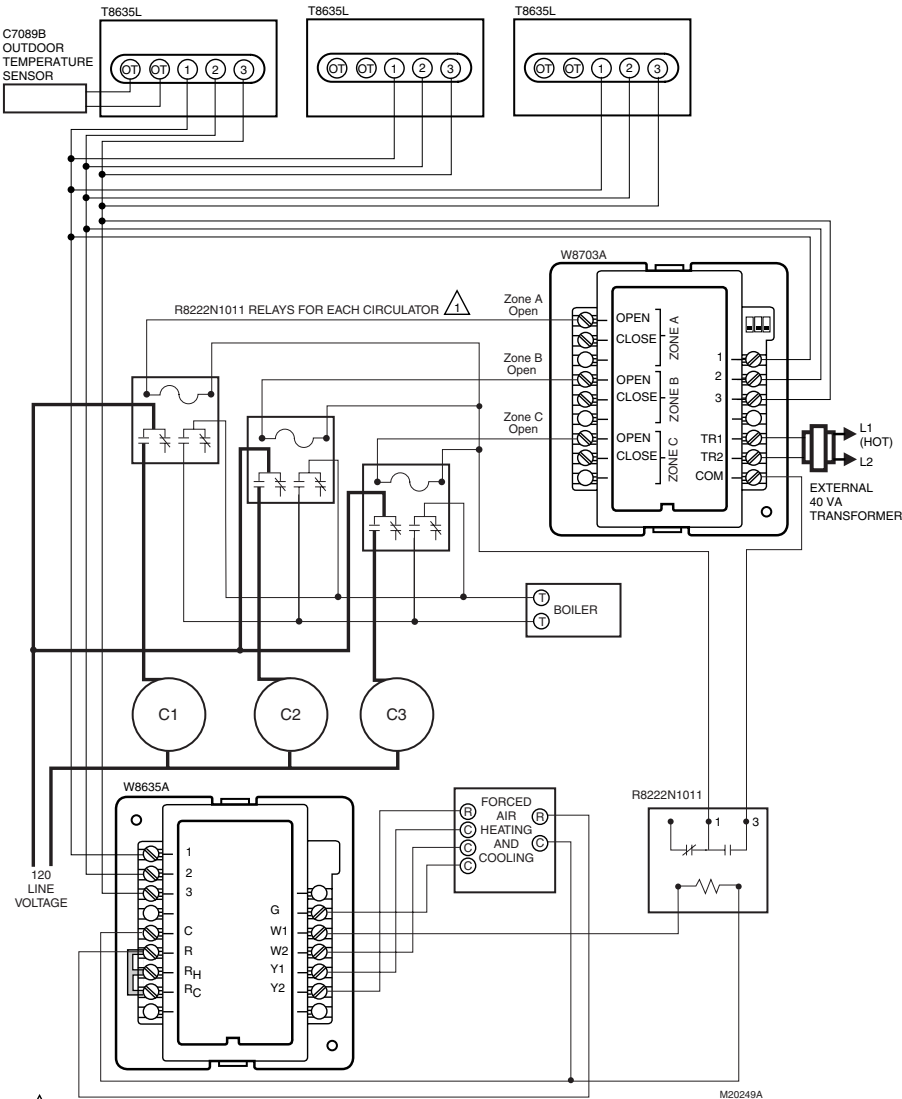

Fig. 8. Hydronic heat with circulators and non-zoned air conditioning wiring diagram.

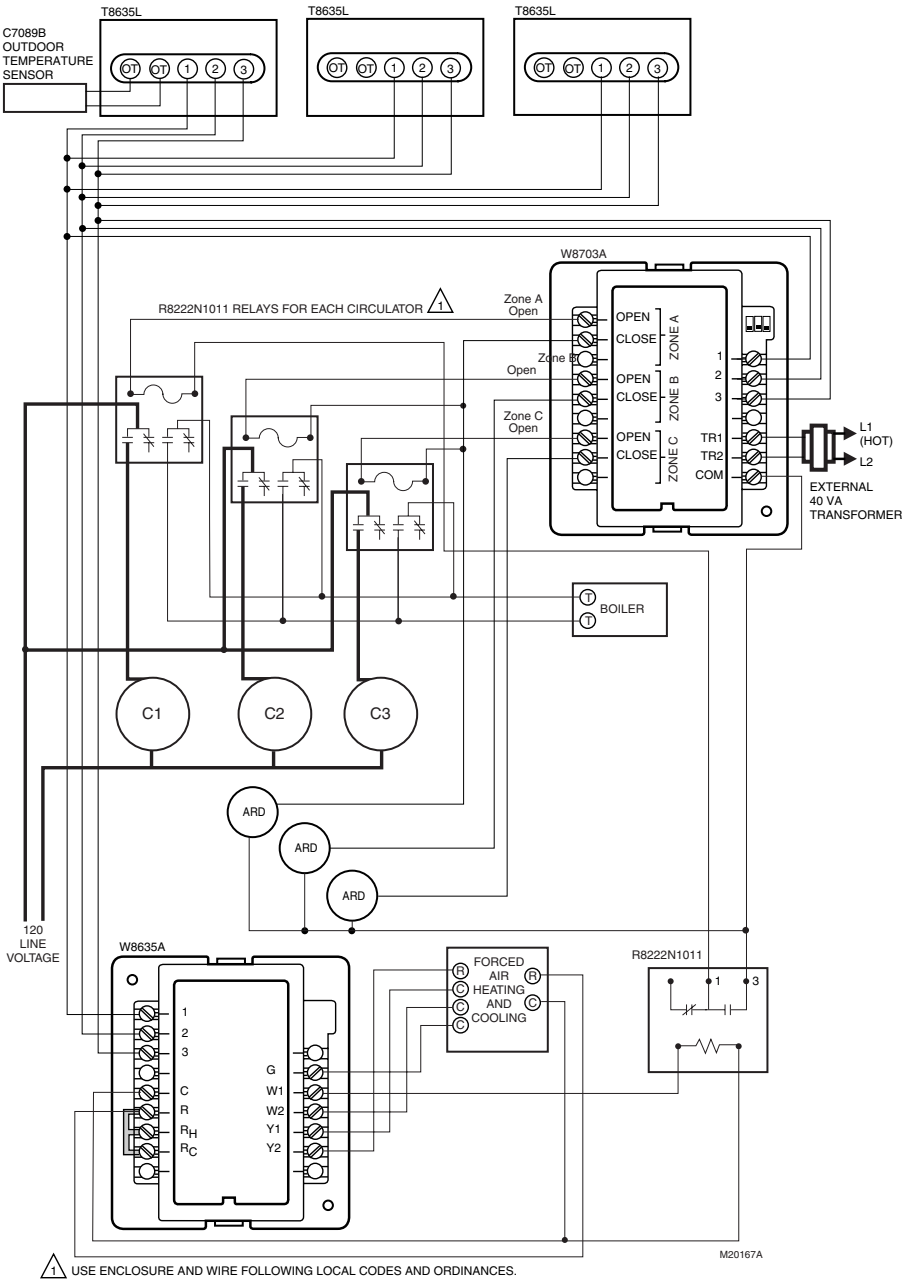

Fig. 9. Hydronic heat with circulators and air conditioning zoned with dampers wiring diagram.

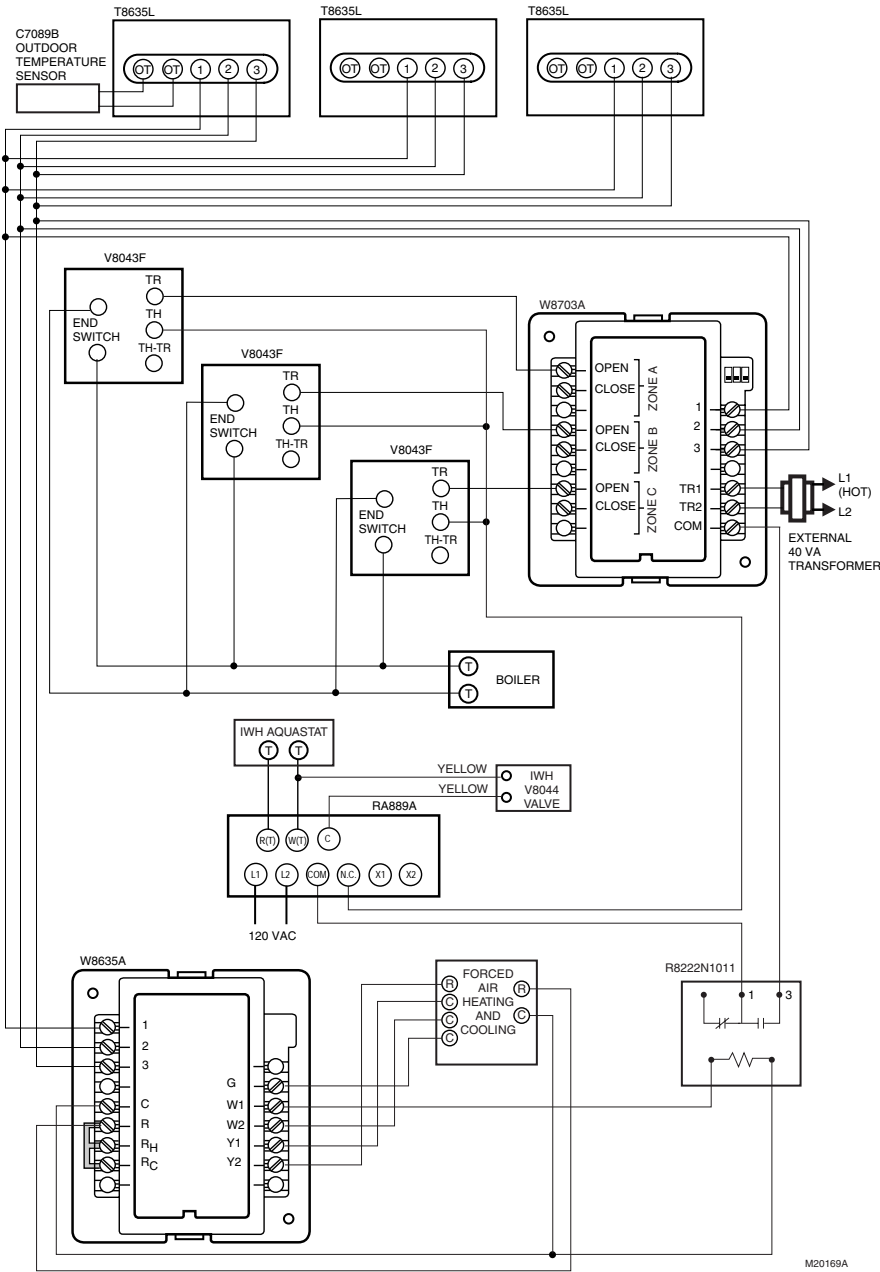
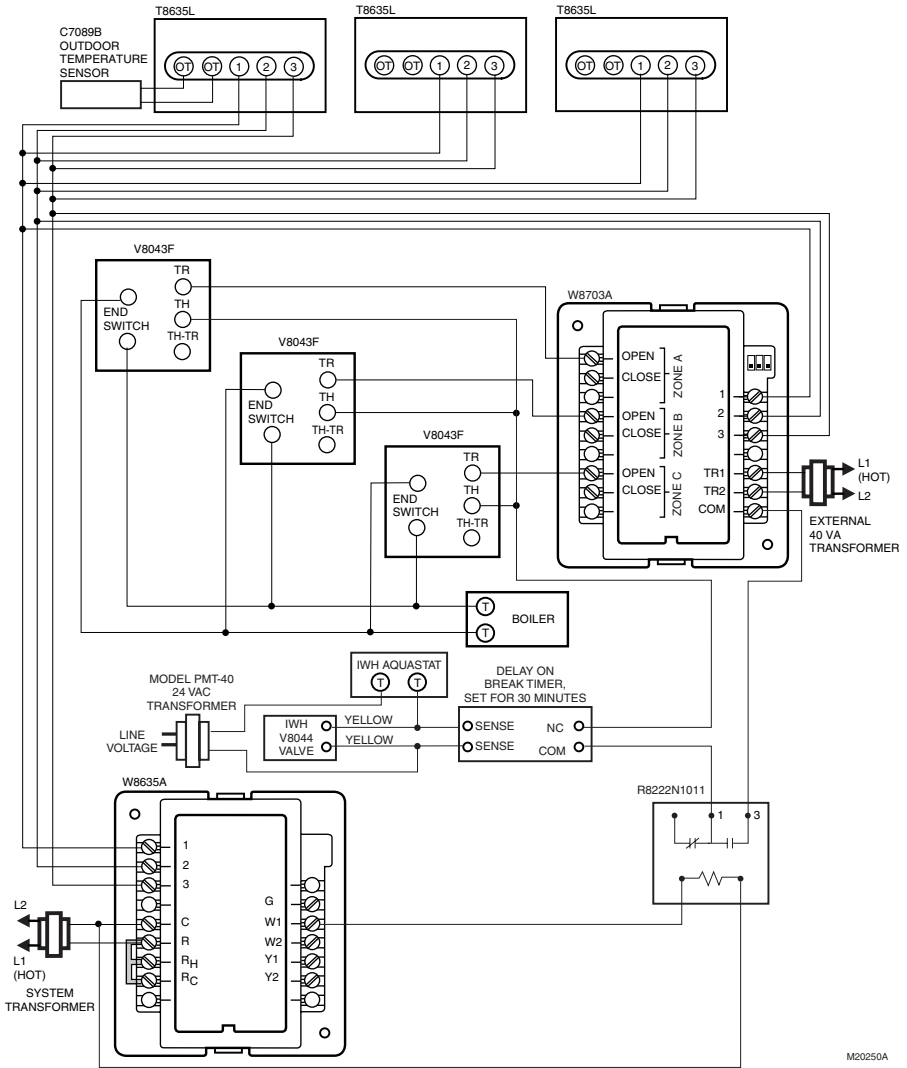

Fig. 10. Hydronic heat with V8043 zone valves and indirect water heater wiring diagram.



M20250A

Fig. 11. Hydronic heat with time-out and indirect water heater with no air conditioning wiring diagram.

Wiring W8703 For Hot Water Zoning

Hydronic Zone Applications

Networked zoning can be used to control hydronic systems with or without ducted air conditioning systems. The damper interface module controls a 24 Vac zone valve directly or a 120 Vac circulator using isolation relays.

HYDRONIC ZONING WITH ZONE VALVES

Networked Zoning can control a hydronic system using Honeywell V8043 or similar zone valves. The zone valve end switches are wired in parallel and connected to the Aquastat on the boiler. A relay is used to prevent the dampers from opening when the heating system is idle. See Fig. 5.

In a ducted air conditioning system, dampers are connected as shown in Fig. 6. Power closed, spring open, round ARD or rectangular ZD dampers are recommended. Three-wire, power open/power closed dampers such as the AOBD are wired as follows:

- The first W8703 Damper Interface Module drives the zone valves using its open contacts.
- The second W8703 Damper Interface Module, addressed with the same DIP switch settings as the first W8703 (Fig. 12-14) drives the AOBBD damper.
- AOBBD dampers open and close on a call for heat and on a call for cool. An optional isolation relay can be used to depower the common wire to the second W8703 to prevent a call for heat from the operating damper on a call for heat. Wire the coil to Y1 and C on the W8635A.

NOTE: The transformer must be appropriately sized to supply power to the total valve load (60 VA maximum or 30 VA maximum valve load per zone).

HYDRONIC ZONING WITH CIRCULATORS

Networked zoning can control a hydronic system zoned with circulators. The damper module damper terminals are wired to isolation relays that control the 120 Vac circulator. See Fig. 8.

If the system uses ducted air conditioning, wire using Fig. 9.

PRIORITY ZONING

When an indirect water heater (IWH) is used, the domestic water can be put on a priority zone. This directs all the available heat from the boiler to the IWH, if present, when a call for domestic hot water occurs.

Fig. 10 shows an isolation relay used to remove power from the room-heating zones valves whenever the IWH Aquastat calls for heat. In addition to powering the isolation relay, the IWH Aquastat also powers the zone valve for the IWH loop.

Fig. 11 shows a method of adding a time-out feature to Fig. 10. This feature prevents the Aquastat from stealing the heat for extended periods.

RELAY AND BOILER CONTROL PANELS

Networked zoning can control Honeywell zone valve or circular panels. Wire similar to Fig. 7 but wire the normally open contacts on the circulator relays to zone thermostat R or W contacts on the panel.

On Argo or Taco panels, connect the normally open contacts to the TT terminals on the panel.

On Tekmar panels, connect the normally open contacts where the end switches or thermostats are shown in the Tekmar installation instructions.

SETTINGS

T8635 Thermostat Settings

The T8635 Thermostats must be configured using Installer Setup. See Installer Setup 51 in Table 6 of the T8635 Thermostat Installation Instructions.

Set Installer Setup 51 for the correct cycle rate. Use 6 cph for conventional forced air. Use 3 cph for high-efficiency forced air or hydronic applications.

Set Installer Setup 5 to the number of stages of heat. For example, set to 1 for a single-stage heat system.

Set Installer Setup 8 for the number of stages of cooling. For example, for one stage of cooling, set it to 1. For a heat only application, set it to 0.

W8703 DIP Switch Settings

Zones a, b, and c on the W8703 correspond with the thermostat configuration zones 1, 2, and 3, respectively. DIP switches are set in the factory as shown in Fig. 12.



Fig. 12. Zones 1-3 DIP switch settings.

When two W8703 are connected and the DIP switch is configured on the second module as shown in Fig. 13, zones a, b, and c on the W8703 correspond with the thermostat configuration zones 4, 5, and 6, respectively



Fig. 13. Zones 4-6 DIP switch settings.

When three W8703 are connected and the DIP switch is configured on the third module as shown in Fig. 14, zones a, b, and c on the W8703 correspond with the thermostat configuration zones 7, 8 and 9, respectively.



Fig. 14. Zones 7-9 DIP switch settings.

LED Indicators

There are four LED on the W8703A used to indicate damper position and system communications.

DAMPER POSITION LED

Three two-color LED on the left side of the base are red when the W8703A is commanding the damper closed, and green when commanding the damper open.

COMMUNICATION LED

One green LED on the right side of the base flashes periodically to indicate that system communications are functional.

CHECKOUT AND TEST

When power is initially applied to the W8703A, the connected dampers are in the Open position.

To test for proper wiring of the W8703A and the associated zone dampers:

1. Make sure that the zone thermostats are not calling for heating or cooling and that the thermostat Fan setting is in the Auto position. All heating and cooling equipment, including the system fan, should be off. All zone dampers should be in the Open position (status LED green).
2. Initiate a call for heating or cooling on the Zone 1 thermostat. The system should start, the Zone 1 damper should remain open and all other dampers should close.
3. Initiate the same call in each of the remaining zone thermostats. The damper in each zone should open in response to this action.
4. Remove the call for heating or cooling in each thermostat. The damper in each zone should close in response to this action.
5. After all calls for heating and cooling are removed, the system blower should stop and all dampers should return to the Open position.

TROUBLESHOOTING GUIDE

Symptom	Possible Cause	Action
No LED are on.	Panel is not powered.	Check for 24 Vac between TR1 and TR2 terminals; if missing 24 Vac: — Check if the circuit breaker is tripped; if so, reset the circuit breaker. — Check if the Power switch on the HVAC equipment is in the Off position; if so, set to the On position. — Check wiring between the thermostat and HVAC equipment—replace any broken wires and tighten any loose connections. — If 24 Vac is present, proceed with troubleshooting.
Damper does not open/close when expected.	System communications are incorrectly connected.	Verify that system communications LED is periodically blinking; if not: — Check wiring of system. Verify that system terminals 1, 2 and 3 are correctly connected.
	Damper is incorrectly connected to Damper Interface Module.	Verify correct color of LED is visible: red for Closed and green for Open; if correct: — Check wiring of damper. Verify that Open, Close and Com terminals are correctly connected to damper terminals.

Honeywell

Automation and Control Solutions

Honeywell
1985 Douglas Drive North
Golden Valley, MN 55422

Honeywell Limited-Honeywell Limitée
35 Dynamic Drive
Scarborough, Ontario
M2H 3N7

