

# Aprilaire®



## Automatic Digital Humidifier Control

### Safety and Installation Instructions

**READ COMPLETE INSTALLATION INSTRUCTIONS  
AND TEMPLATE BEFORE STARTING.**

#### **WARNING**

**ATTENTION INSTALLER:** This product must be installed by a qualified heating and air conditioning contractor. Failure to do so could result in serious injury from electrical shock.

## **⚠ WARNING**

1. 120 volts may cause serious injury from electrical shock. Disconnect electrical power to the HVAC system before starting installation.
2. Sharp edges may cause serious injury from cuts. Use care when cutting plenum openings and handling ductwork.

## **⚠ CAUTION**

1. Do not set humidity higher than recommended. Condensation damage may result.
2. Do not set humidity up to recommended levels if there is condensation on the inside of windows of any unheated living space. Condensation damage may result.
3. Do not mount the Humidifier Control on the supply plenum or duct. The unit cannot withstand supply temperatures and will malfunction.
4. When installing the Humidifier Control on a counterflow furnace, ensure the blower continues to run after a heat call is satisfied to eliminate high temperatures from damaging the Humidifier Control.
5. Do not mount the Humidifier Control downstream of the bypass outlet. False humidity conditions will cause the humidifier to operate incorrectly.
6. Avoid installing the Humidifier Control with the display facing downward to prevent the Humidifier Control from incorrectly measuring the relative humidity (RH) in the duct.

## **TABLE OF CONTENTS**

Installation .....	page 3
System Checkout .....	page 20
Troubleshooting .....	page 22

**THESE INSTALLATION INSTRUCTIONS ARE FOR THE APRILAIRE AUTOMATIC DIGITAL HUMIDIFIER CONTROL ONLY! For Aprilaire® humidifier installation, follow Aprilaire Humidifier Installation Instructions.**

## **INSTALLATION**

### **STEP 1: Unpack the Humidifier Control Carton**

Make sure all components are present (see **Figure A**):

- A.** Humidifier Control
- B.** Outdoor Temperature Sensor
- C.** Manual Mode Label
- D.** Manual Mode Resistor Case

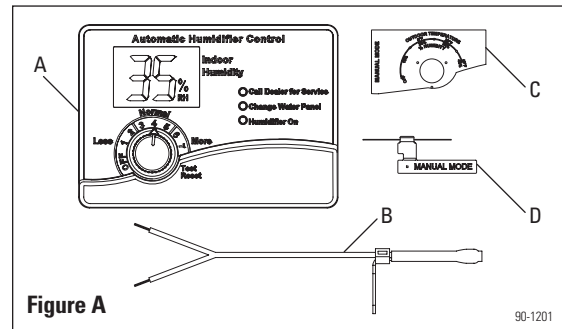

## STEP 2: Disassemble the Humidifier Control

Remove the knob. Remove the cover by pulling at the bottom and swinging it out and upward.

## STEP 3: Check the Mode Switch

See **Figure G** (on page 11) for the mode switch (labeled A and B). Make sure the switch is correctly set for the type of humidifier installed.

**Set the Mode Switch in position A for Models: 220, 224, 400, 400A, 440, 500, 500A, 500M, 550, 558, 560, 568, 600, 600A, 600M, 700A and 700M**

**Set the Mode Switch in position B for Models: 110, 112, 445, 448, 700, 760 and 768**

Do not operate the humidifier with the Mode Switch in the wrong position. Damage to the Humidifier Control could result.

## STEP 4: Check the Change Water Panel indicator setting.

This setting will control when the indicator light turns on, reminding you to change your water panel. If your Control came with a humidifier, the Control is pre-set for the humidifier. If the installation site has a 3-month or shorter heating season or very hard water, you may want to adjust the setting (see **Figure B**).

**Figure B**

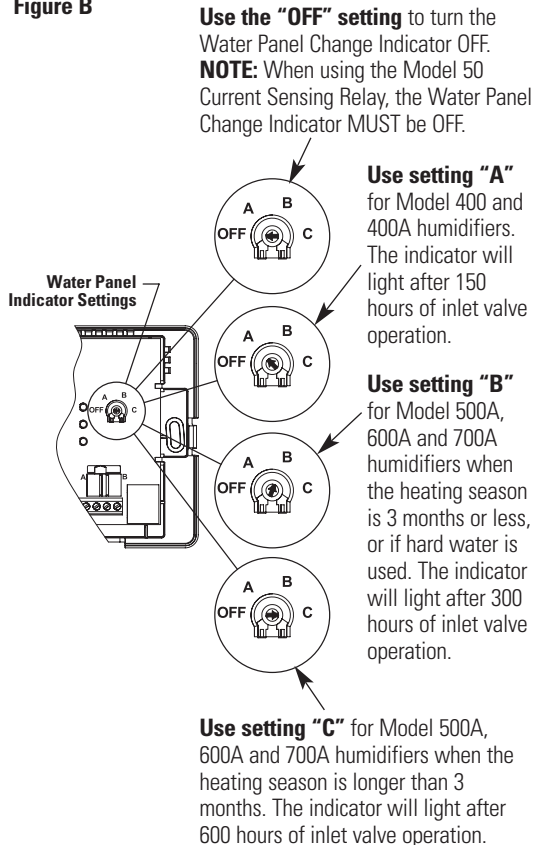

90-1202

## STEP 5: Determine Location for Humidifier Control and Mount Control

Humidifier Control must be mounted on the Return Duct, at least 6 inches upstream of the following (see **Figure C**):

- Humidifier
- Humidifier Bypass Ductwork (if applicable)
- Fresh Air Intake Ductwork (if applicable)

Operating temperature of the Humidifier Control is to be from 20°F to 120°F to prevent damage to the control display.

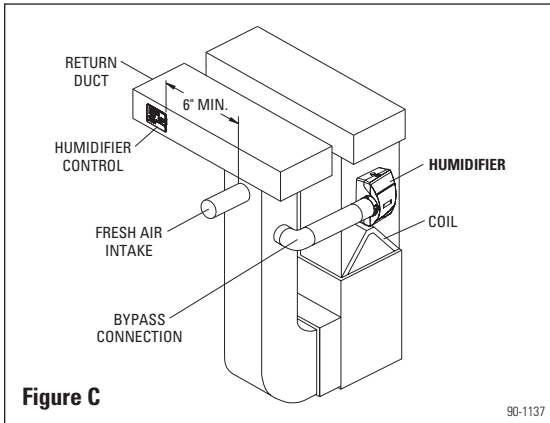

## DUCT (SHEET METAL) MOUNT:

After location for Control is selected, drill a 3/4 inch hole for the RH sensor (the RH sensor extends from the back of the Humidifier Control).

Use 2 sheet metal screws, 3/4 inch long (not provided), to mount the Humidifier Control. Use the mounting slot to level the Control, then secure the Control with the second sheet metal screw.

Make sure the Humidifier Control sensor gasket is seated tightly around the drilled hole. Do Not Install Control Without Gasket. Reattach cover and knob.

## DUCT (FIBER BOARD) MOUNT:

After location for Control is selected, cut a rectangular hole in the duct board, no smaller than 6-9/16 inches long by 4-3/8 inches wide.

Cut a rectangular piece of sheet metal to fit behind the hole in duct board for mounting the Humidifier Control.

Drill a 3/4 inch hole for the RH sensor (the RH sensor extends from the back of the Humidifier Control) into the sheet metal plate.

Use 2 sheet metal screws, 3/4 inch long (not provided), to mount the Humidifier Control.

Make sure the Humidifier Control sensor gasket is seated tightly around the drilled hole. Do Not Install Control Without Gasket.

Secure the sheet metal plate, with the Humidifier Control mounted, inside the duct (see **Figure D**). Reattach cover and knob.

## CONTROL REPLACEMENT:

When replacing an existing control, the duct opening left by the removed control must be covered completely. Locate and install the new control as instructed previously in Step 5.

**Figure D – Fiber Board Duct Mount**

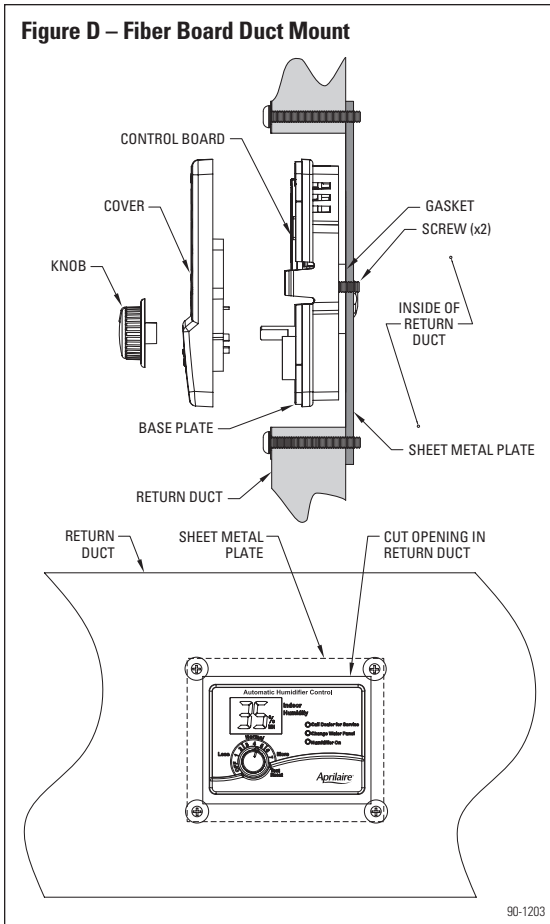

90-1203

**STEP 6: Determine Location for Outdoor Temperature Sensor**

The location of the Outdoor Temperature Sensor must meet these three requirements:

1. Must be mounted on North, East or West side of house out of direct sunlight
2. Must be at least 3 feet from all exhaust vents
3. Must be above expected snow line (see **Figure E**)

Incorrect humidity levels will result if these requirements are not met.

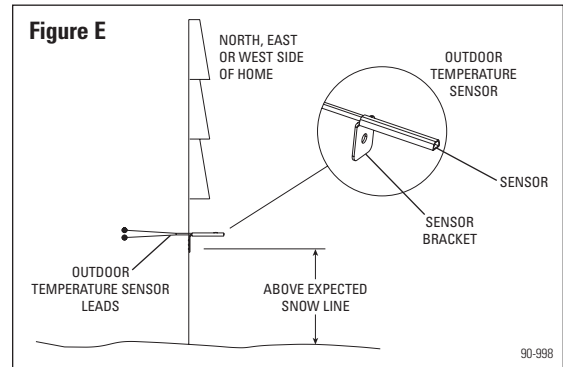

**STEP 7: Locate Existing Access Hole to Outside**

A convenient way to get the Sensor wire outside is to make use of unused wires running to the A/C condensing unit (if applicable). Other ways are to use existing holes for Cable TV lines, telephone lines, A/C lines, etc. Read all equipment instructions beforehand for possible conflicts and warnings.

### STEP 8: Alternate Location for Outdoor Temperature Sensor

The Sensor can also be mounted in the center of either:

- PVC fresh air intake pipe for the HVAC system

**OR**

- fresh air intake duct. Mount the sensor with a #8 galvanized screw.

**In both cases, the Sensor must be no more than 3 feet from the outside wall. See Figure F.**

If it is not feasible to use the Outdoor Temperature Sensor in any of the ways described, the Humidifier Control can be installed for Manual Operation. See “Installing the Humidifier Control for Manual Operation” and **Figure H** on page 12 for details.

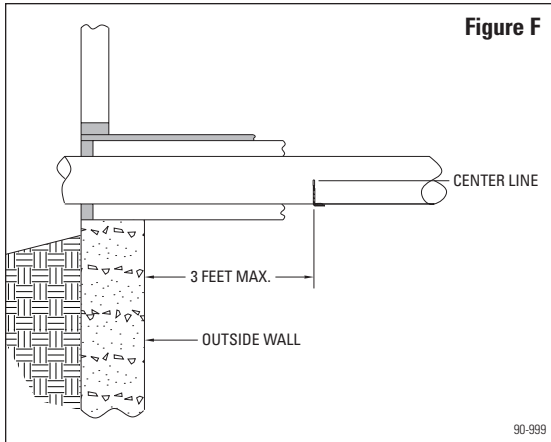

### STEP 9: Route the Wire from Control to Sensor

Run wire to the outdoor temperature sensor. Sensor is not affected by lead length. Do not run outdoor temperature sensor alongside wires carrying high voltage (120 VAC or higher). Secure the sensor bracket with a #8 screw.

### STEP 10: Attach Sensor Wire to Humidifier Control

Strip wire 1/4 inch, and insert the wires from the Sensor into the terminals labeled “ODT” on the Humidifier Control. See **Figure G** for location of terminals.

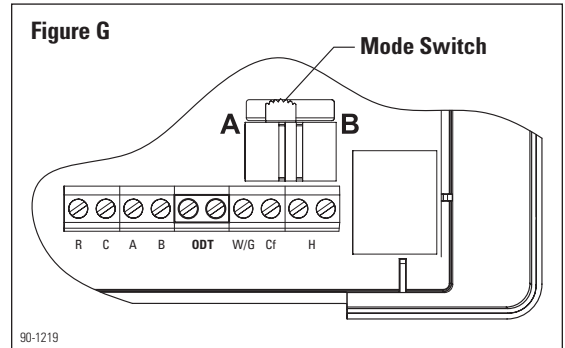

## Installing the Humidifier Control for Manual Operation

If it is not feasible to install the Outdoor Temperature Sensor, the Humidifier Control can be operated in Manual Mode.

1. Connect the Manual Mode Resistor Case wires to the terminals labeled "ODT" on the Humidifier Control.
2. Position the Manual Mode Resistor Case so that the Resistor Case extends from the bottom edge of the base.
3. Apply the Manual Mode label to the cover, aligning the sticker and knob holes.

Figure H

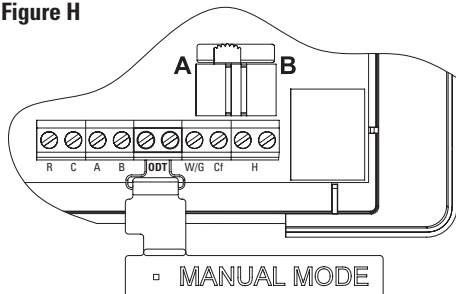

## STEP 11: Power Source for Humidifier Control – Terminals R and C

Wire external 24 VAC transformer into a constant power source other than the heating, ventilating, air conditioning equipment (HVAC) blower circuit. The transformer can be powered off the 120 VAC line at the junction box before it enters the HVAC. Connect the 24 volt side of the transformer to the "R" and "C" terminals on the Humidifier Control.

### NOTES:

- The Humidifier Control must be continuously powered for proper functionality.
- The minimum VA required is:
  - 2.0 VA** for humidifier Models 110, 112, 445, 448, 700, 760, 768
  - 10.0 VA** for humidifier Models 220, 224, 400, 400A, 440, 500, 500A, 500M, 550, 558, 600, 600A, 600M, 700A, 700M.

## STEP 12: Humidifier Wiring – See Figures J through P

Strip the wires used for all Humidifier Control terminal connections 1/4 inch.

### NOTES:

- In order for the humidifier to operate, the HVAC blower must be running and the Humidifier Control must be calling for humidity.
- There are several ways to detect HVAC blower operation. See the wiring diagrams for options.

## USING FURNACE ACCESSORY TERMINALS TO DETECT FURNACE OPERATION (FIGURE J)

See the furnace manual for voltage and operation of the accessory terminals. If accessory terminals are 120 Volts, install a 24 VAC transformer.

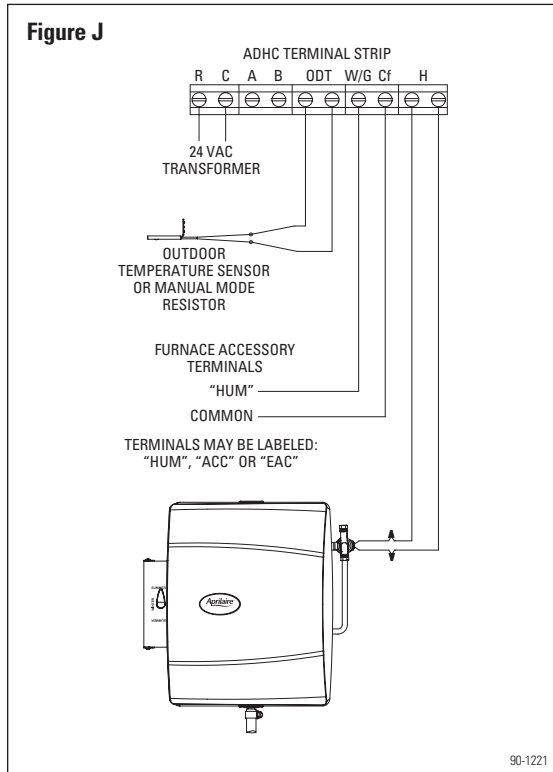

## USING FURNACE TERMINALS TO DETECT FURNACE BLOWER OPERATION (FIGURE K)

This configuration allows the humidifier to run only during heat call, even if the thermostat is set for continuous fan operation.

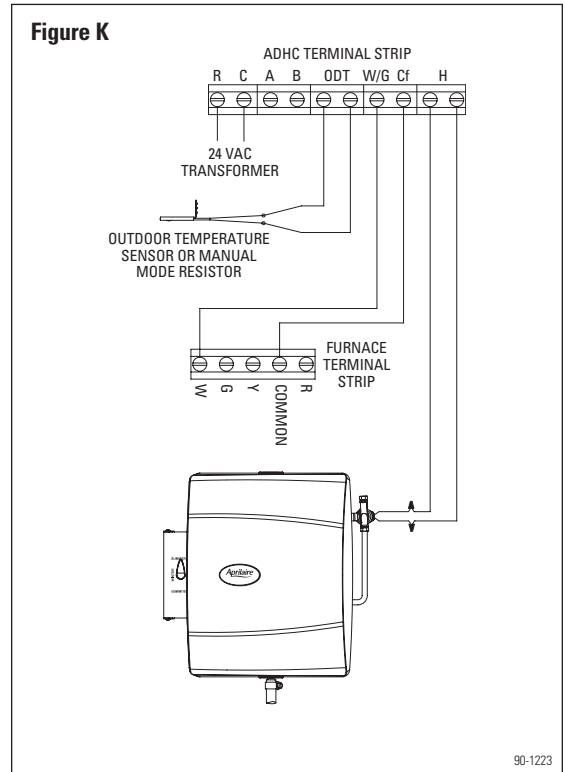

## OPERATING THE HUMIDIFIER WITH CONTINUOUS FAN OPERATION (FIGURE L)

This configuration allows the humidifier to run whenever the HVAC blower is running and the Humidifier Control is calling for humidity. This option is for applications that require more humidity than can be delivered during heat calls.

**NOTES:** The humidifier solenoid should be plumbed to hot water for this option.

The thermostat must be set for continuous fan operation for this option.

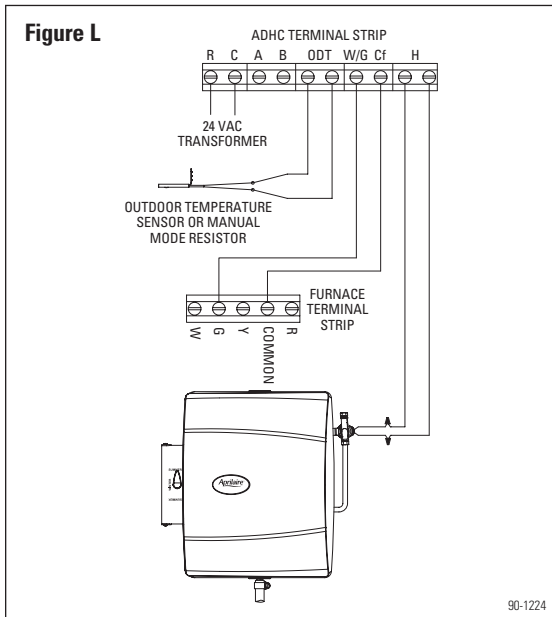

## HEAT PUMP WIRING (FIGURE M)

This configuration allows the humidifier to run whenever the heat pump blower is running (and the Humidifier Control is calling for humidity). The humidifier solenoid should be plumbed to hot water for this option.

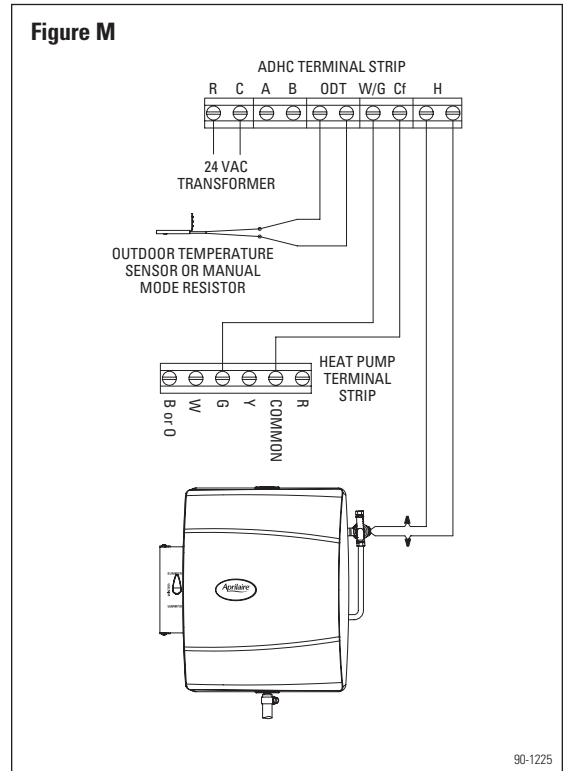

## USING MODEL 50 CURRENT SENSING RELAY TO DETECT FURNACE BLOWER OPERATION (FIGURE N)

This option is to be used only if the furnace terminals or accessory terminals are not used.

**NOTE:** The Water Panel Change Indicator must be set to the "OFF" position for this option.

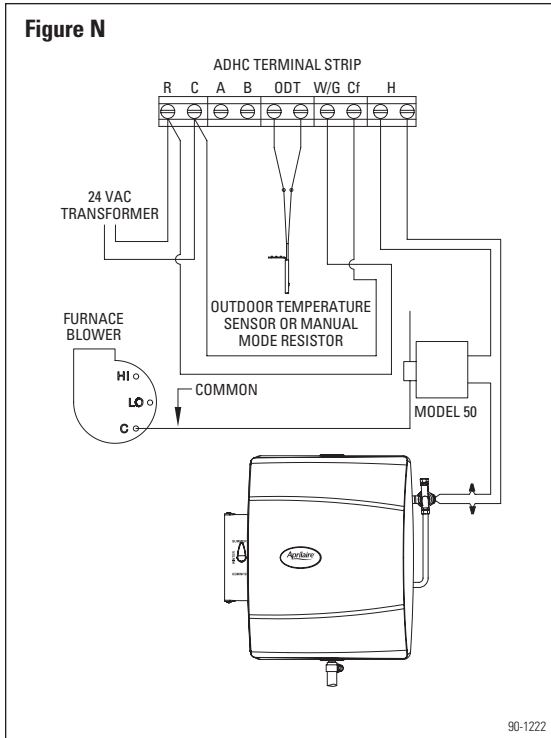

## MODEL 8570 THERMOSTAT OPTION (FIGURE P)

The Model 8570 Thermostat provides the signal that the HVAC is operating. The outdoor temperature sensor can be connected to the Humidifier Control or to the Model 8570. If the Humidifier Control is operating in Manual Mode, the Model 8570 will display a constant outdoor temperature of about 20°F.

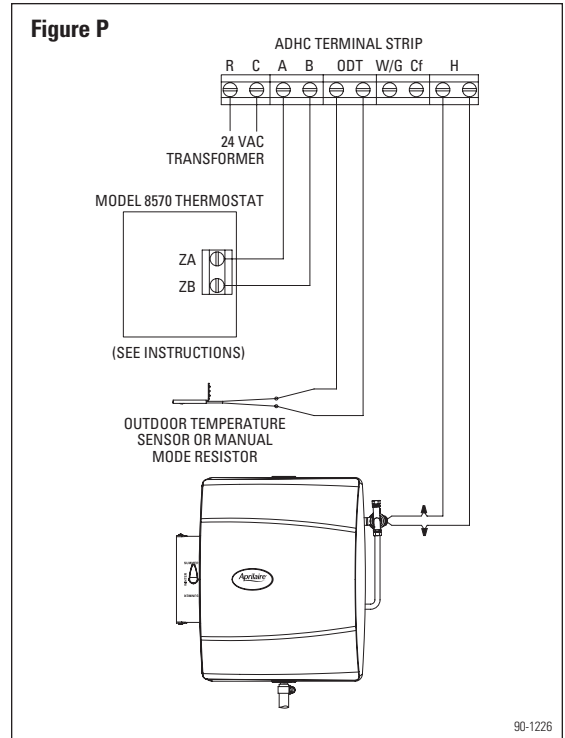

## SYSTEM CHECKOUT

1. Replace the cover by snapping it into the Humidifier Control base. Also replace the knob onto the Control.
2. Restore power to the heating system.
3. Activate the HVAC system or heat pump.
4. Once the blower is operating, rotate the knob of the Humidifier Control Clockwise to the "Test/Reset" position. When the knob is set in the "Test/Reset" position, the green "Humidifier On" light will illuminate. After 5 seconds, the green "Humidifier On" light will blink, indicating a system reset.
5. If the Humidifier Control and humidifier are set up properly, you should hear the solenoid valve click into the open position. In the "Test/Reset" position, the humidifier will operate for 1 minute. If the Humidifier Control is left in the "Test/Reset" position for more than 1 minute, the "H" terminals will de-energize (closing the solenoid valve), and the knob and display backlights will flash, indicating that the Humidifier Control is still in the "Test/Reset" position.
6. If the humidifier does not activate with the Humidifier Control in the "Test/Reset" position, refer to the troubleshooting guide.
7. Setting the Humidifier Control:
  - If the home is occupied, set the Humidifier Control to "Normal" (For Manual Mode, set to 35%)
  - If the home is vacant, set the Humidifier Control to "OFF"
  - If in Manual Mode and system is installed during cooling season, set the Humidifier Control to "OFF"
8. Instruct the homeowner to refer to the Aprilaire Owner's Manual for the initial adjustment period.
9. Make sure the red "Call Dealer for Service" light is not flashing. If the red "Call Dealer for Service" light is flashing, refer to the troubleshooting guide.

## TROUBLESHOOTING

Applies to both Automatic and Manual Operation unless indicated otherwise.

### SYMPTOM

Call Dealer For Service Light Flashing (see **Figure Q**)

### TROUBLESHOOTING PROCEDURE

#### **Display Error Code: E1:** RH Sensor

Rotate Humidifier Control knob to the “Test/Reset” position. After 5 seconds, the green “Humidifier On” light will blink, resetting the error. If E1 returns, replace the Humidifier Control.

#### **Display Error Code: E2:** Control Knob

Rotate Humidifier Control knob to the “Test/Reset” position. After 5 seconds, the green “Humidifier On” light will blink, resetting the error. If E2 returns, replace the Humidifier Control.

#### **Display Error Code: E3:** Outdoor Temperature Sensor

1. Make sure that the Outdoor Temperature Sensor is properly connected to the ODT terminals on the Humidifier Control.
2. Measure the resistance of the Outdoor Temperature Sensor by removing the leads from the Humidifier Control terminals and measuring the resistance across the wires with an ohmmeter. Confirm the reading with the temperature in **Table 1**. (For Manual Operation, verify that the resistance across the leads of the Manual Mode Resistor Case is between 44K and 48K ohms). Reconnect the ODT leads. If the resistance value does not match the temperature value, replace the Outdoor Temperature Sensor.
3. Rotate Humidifier Control knob to the “Test/Reset” position. After 5 seconds, the green “Humidifier On” light will blink, resetting the error. If E3 returns, replace the Humidifier Control.

## TROUBLESHOOTING PROCEDURE (CONTINUED)

### **Display Error Code: E4:** Communication

This only applies to systems wired to an Aprilaire Model 8570 Thermostat (see **Figure P**).

Rotate the Humidifier Control knob to the “Test/Reset” position. After 5 seconds, the green “Humidifier On” light will blink, resetting the error. If E4 returns, check the wiring between the ADHC and Model 8570. Make sure the Model 8570 is wired and operating properly according to the Model 8570 manual.

**TABLE 1**

Outdoor Temperature (°F)	Resistance (kΩ) ±10
-30	231.8
-20	163.4
-10	117.3
0	84.8
10	62.2
20	46.1
30	34.4
40	26.1
50	19.9
60	15.3
70	11.9
80	9.3
90	7.3
100	5.8

**Figure Q**

Red “Call Dealer For Service” Light  
 Yellow “Change Water Panel” Light  
 Green “Humidifier On” Light

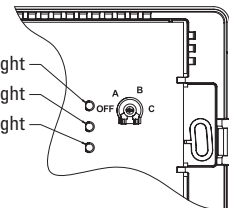

90-1227

<b>SYMPTOM</b>
Humidifier does not operate in "Test/Reset" mode
<b>TROUBLESHOOTING PROCEDURE</b>
<ul style="list-style-type: none"> <li>• Make sure that the blower is operating and the HVAC system is calling for heat.</li> <li>• Check wiring diagrams for correct Humidifier Control installation.</li> <li>• If connected to either a Model 400 or 400A humidifier, make sure both floats in the bottom of the scale control insert are in the down position. If necessary, dump out water to lower the floats.</li> <li>• Check voltage at the Humidifier Control "R" and "C" terminals. Voltage should be 22 VAC minimum to 30 VAC maximum.</li> <li>• Check the Model 50 Current Sensing Relay (if used) for the correct installation (see Model 50 instructions).</li> <li>• Make sure that the saddle valve is open.</li> <li>• In "Test/Reset" mode, the humidifier will operate for 1 minute only. <b>DO NOT LEAVE THE HUMIDIFIER CONTROL IN "TEST/RESET" MODE AS THE HUMIDIFIER WILL NOT OPERATE.</b></li> </ul>

<b>SYMPTOM</b>
Yellow "Change Water Panel" Light is blinking (see <b>Figure Q</b> )
<b>TROUBLESHOOTING PROCEDURE</b>
<p>Check the condition of the Water Panel and replace it if mineral deposits are blocking air flow. Follow the instructions on the Water Panel box. Rotate the knob to the "Test/Reset" position for at least 5 seconds to reset Water Panel change timer. Check that the timer setting is correct for the humidifier model and water conditions (see <b>Figure B</b>). <b>DO NOT LEAVE THE HUMIDIFIER CONTROL IN "TEST/RESET" MODE AS THE HUMIDIFIER WILL NOT OPERATE.</b></p>

### SYMPTOM

Humidifier operates only in "Test/Reset" mode

- If outdoor temperature is greater than 60°F or less than -30°F, the Humidifier Control will only operate in the "Test/Reset" mode (for 1 minute).
- If the humidity level in the home is higher than the Humidifier Control knob setting, the Humidifier Control will not operate the humidifier.

### TROUBLESHOOTING PROCEDURE

- Measure the resistance of the Outdoor Temperature Sensor by removing the leads from the Humidifier Control terminals and measuring the resistance across the wires with an ohmmeter. Confirm the reading with the temperature in **Table 1**. (For Manual Operation, verify that the resistance across the leads of the Manual Mode Resistor Case is between 44K and 48K ohms). Reconnect the ODT leads. If the resistance value does not match the temperature value, replace the Outdoor Temperature Sensor.
- Make sure that the Outdoor Temperature Sensor is mounted completely outside the house on the North, East or West side of the house and out of direct sunlight. (Automatic Mode Only)
- Make sure that the Outdoor Temperature Sensor is located at least 3 feet away from all exhaust vents. (Automatic Mode Only)
- If Outdoor Temperature Sensor is mounted in the fresh air intake duct, make sure that the sensor is no more than 3 feet from the outside wall. (Automatic Mode Only)

### SYMPTOM

Humidifier operates constantly

- If the humidity level in the home is less than the Humidifier Control knob setting and there is a continuous fan call or heat call (depending on setup), the Humidifier Control will operate the humidifier until the humidity level is higher than the Humidifier Control knob setting.

### TROUBLESHOOTING PROCEDURE

- In the "Test/Reset" mode, verify that the humidifier turns off after 1 minute.
- Check the Outdoor Temperature Sensor resistance and location, as instructed on the previous page.
- Rotate the Humidifier Control knob counterclockwise to the "Off" position, and observe whether the humidifier turns off. If the humidifier still operates in the "Off" position, perform the following:
  1. Check the wiring diagram for correct Humidifier Control Installation.
  2. Remove the wires from the "H" terminals on the Humidifier Control. If the humidifier continues to operate, replace the solenoid valve.

### **SYMPTOM**

Humidifier or Humidifier Control “chatters” or clicks On and Off rapidly

### **TROUBLESHOOTING PROCEDURE**

- Check for steady 22 VAC to 30VAC across the “R” and “C” terminals of the Humidifier Control with a voltmeter.
- Check, with a voltmeter, that the HVAC signal across the “W/G” and “Cf” terminals of the Humidifier Control is a steady 22 VAC to 30 VAC.
- Make sure that the Outdoor Temperature Sensor wiring is not running alongside other wires carrying high voltage (120 VAC or higher). (Automatic Mode Only)

RESEARCH PRODUCTS CORPORATION  
P.O. BOX 1467 • MADISON, WI 53701-1467  
Call 800/334-6011 • FAX 608/257-4357

10007267 11.07  
B2204285B