

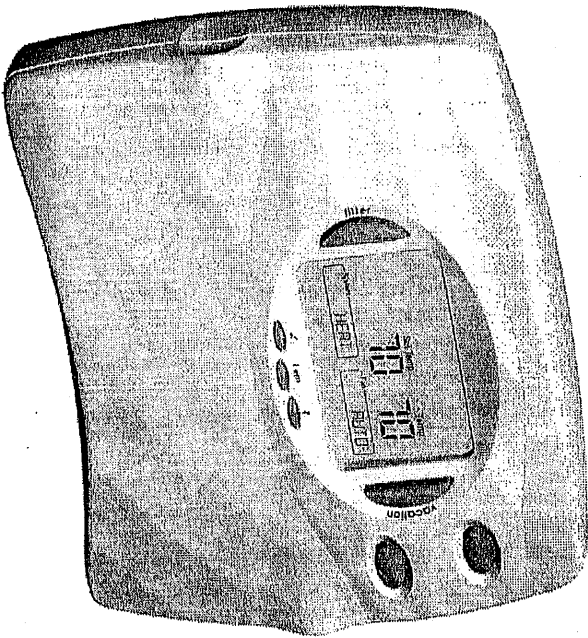

Digital Heat Pump or Multi-Stage Auto Season Thermostat



Owner's Manual

Model 43058

41654-01_final_REV.pmd

1/27/04, 12:45 PM



41664-01_final_REV.pmd

2

1/27/04, 12:45 PM



2

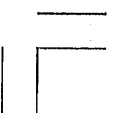

Introduction

CONGRATULATIONS!

Your new Climate Technology electronic thermostat will provide years of reliable service. By saving energy, your thermostat will pay for itself during its first season of use. Thank you for buying a Climate Technology product!

Please read this manual for complete instructions on installing and operating your thermostat. If you require further assistance, call Climate Technology Technical Support at 800-676-7861 from 8 AM to 5 PM Central Time.

Model Information:

Model Number 43058

Serial Number _____

Date Purchased _____

Where Purchased _____

Table of Contents

4

INTRODUCTION

Read This Before Installing Thermostat

6

Features

8

INSTALLATION

What You Need

10

Selector Switches

10

Remove Old Thermostat

12

Wire Labeling

13

Mount Wallplate and Thermostat

16

Connect Wires and Mount Thermostat Cover to Wallplate

17

OPERATION

Option Menu

18

Power Switch

21

System Selection Key

22

Fan Key

23

System Indicator Light

24

Emergency Heat

25

Setting the Thermostat

25

Vacation Hold

26

OPERATION (continued)

Auto Season Changeover	27
Filter Monitor	28
SPAN Settings	29
Keyboard Lock	30
Backlighting (INDIGLO® Night-Light)	30
Remote Sensors	31
AC Power Monitor	34
Low Battery Warning	35
Error Mode	35
Problems & Solutions	36
Technical Support	37
Heat Pump Systems	38
Multi-Stage Systems	39

WIRING DIAGRAMS

TROUBLESHOOTING

Read This Before Installing Thermostat

6

IMPORTANT

1 Read the entire installation section of this Owner's Manual thoroughly before you begin to install or operate your Climate Technology Thermostat.

INSTALLATION

2 All installation is normally performed at your thermostat.

ARMCHAIR PROGRAMMING

3 You can set-up your thermostat before installation by inserting the batteries and following the instructions starting on page 18. This can be done while you relax in your favorite chair and is a very good way to familiarize yourself with all the functions of your Climate Technology Thermostat.

SYSTEM COMPATIBILITY

4 Your Thermostat is designed to operate these 24-Volt systems:

- Multi-stage heat pumps with auxiliary heat
- Multi-stage systems (2 stage heat, 2 stage cool)

This thermostat will not control 120/240 Volt systems or millivolt systems.

COMPRESSOR PROTECTION

5 The thermostat provides a 3.5 minute delay after shutting off the heating or cooling system before it can be restarted. This feature will prevent damage to your compressor caused by rapid cycling.

TEMPERATURE RANGE

6 Your thermostat can be set between 45°F and 95°F (7°C and 35°C). However, it will display room temperatures from 15°F to 99°F (-9°C and 37°C). "H" will be displayed if the temperature is higher than 99°F (37°C), and "L" will be displayed if the temperature is lower than 15°F (-9°C).

OPERATION

7 This system operates on your system's 24 Volt power supply. The supply is monitored by the thermostat, and it will stop functioning if AC power is lost. (When using backup batteries, "No AC Pwr" will be displayed.) All system controls will remain off until power is restored.

NOTE: The INDIGLO® Night-Light will not function when AC power is lost.

NOTE: Any remote temperature sensors (if used on your system) will not operate when AC power is lost.

BATTERY WARNING

8 Batteries may be used optionally to prevent the loss of your thermostat's clock, programs and options due to a power outage. However, when the batteries become drained, a low battery warning will appear on the display. When this message occurs, install 2 new AAA batteries. You have approximately 30 seconds when changing the batteries to keep thermostat's clock and program settings.

NOTE: The default system selection at power-on is HEAT. Batteries are recommended to prevent an undesired system change due to a power outage.

Features

INDIGLO® Night-Light
activated by pressing any key.

Alpha-numeric display shows current temperature, set temperature, and other feature information as required.

Vacation: Hold a different temperature for a selected number of days.

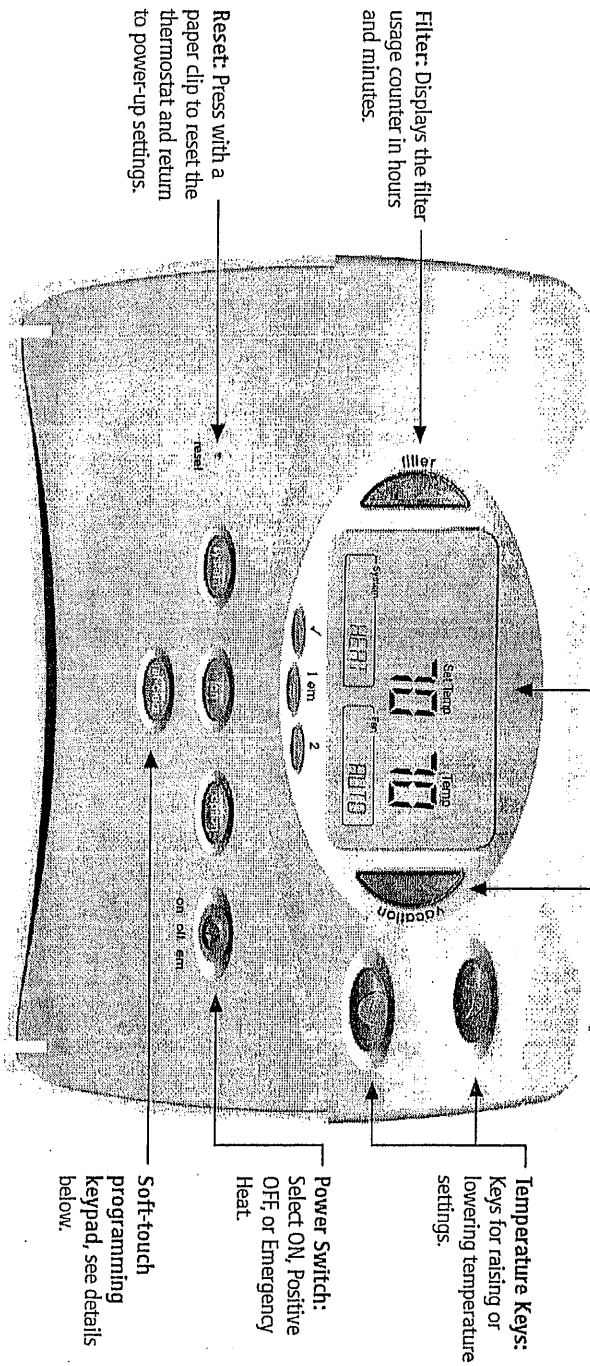

System Indicator LEDs:
Show status of Stage 1,
Emergency, Stage 2, and
Check System.

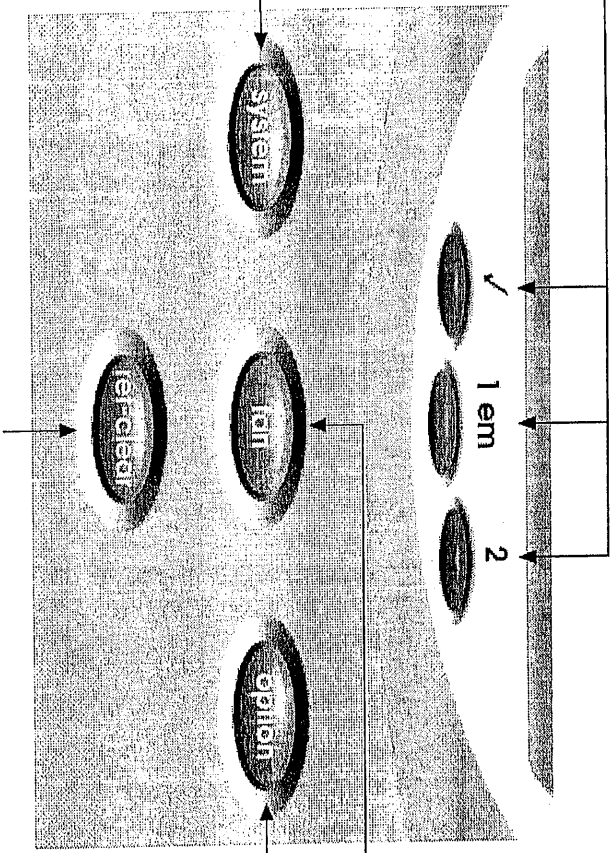

System Key: Use to
select system. Select
Heat, Cool or Auto.

Fan Key: Used to
select fan mode.
Select AUTO or ON.

Return-Clear Key: Returns to normal display mode.
Also clears Filter counter and Vacation modes.

Option Key: Enters
the option menu.

INSTALLATION

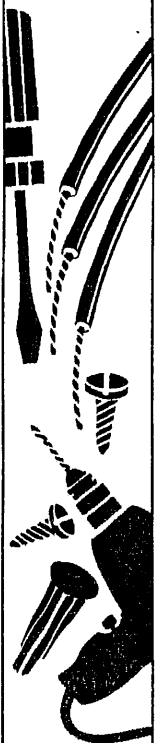

10

What You Need

This thermostat includes two #8 slotted screws and two wall anchors for mounting. To install your thermostat, you should have the following tools and materials.

- Slotted Screwdriver(s)
- Phillips Screwdriver
- Hammer
- Electric drill and 3/16" bit
- Two 1.5 V (AA) size alkaline batteries

Selector Switches

In order for this Climate Technology thermostat to control your system, the system type must be specified by selector switch on the rear inside of the thermostat. There are also other selector switches that allow you to customize the features to suit your needs. Refer to Figure 2 for removal of wallplate.

NOTE: When changing these features after installation, move the power switch to OFF before removing the thermostat from the wall.

System Selector Switches:

- Heat Pump or Multi-Stage selector (HP-MS switch)

The factory position for this switch is in the "HP" position. Leave it in this position if you have a heat pump system or need emergency heat control.

If you have a conventional multi-stage system (more than 1 stage of heat or cool), then slide the switch to the "MS" position.

NOTE: The Emergency Heat Function operates both stages of heat at the same time when in multi-stage mode.

INSTALLATION

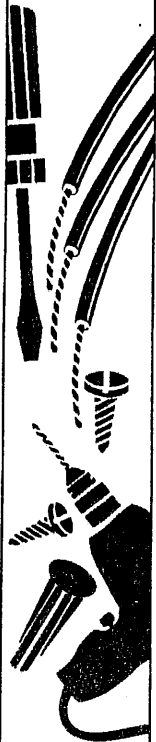

12

Remove Old Thermostat

CAUTION: Do not remove any wiring from existing thermostat before reading the instructions carefully. WIRES MUST BE LABELED PRIOR TO REMOVAL.

- IMPORTANT! Turn off the power to the furnace at the main power panel or at the furnace.
- Remove existing thermostat cover. See Figure 1. Some thermostats will have screws or other locking devices that must first be removed. Once wall mounting plate is exposed, look for wires.

If wires are not visible, they may be connected to the back of the wallplate. Again, look for screws, tabs, etc. Some models have doors that open to expose wires and mounting screws. (See Figure 1).

TYPICAL HOME THERMOSTATS

Figure 1

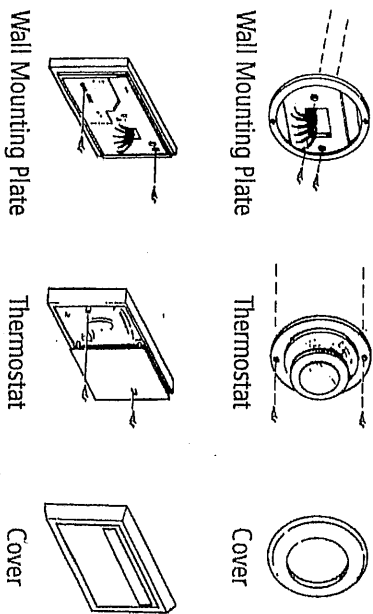

Wire Labeling

- Each wire coming from the wall to the existing thermostat is connected to a terminal point on that thermostat. Each of these terminal points is usually marked with a code letter as shown in Table A below and on the next page.
- The number of wires in your system can be as few as four (for single-stage systems), as many as eight, or any number in between. If you follow the labeling procedures correctly, you do not have to be concerned about how many wires there are.
- IMPORTANT! BEFORE DISCONNECTING ANY WIRES, APPLY THE SELF-ADHESIVE LABELS PROVIDED TO THE WIRES AS**

TABLE A – TERMINAL DESCRIPTIONS

TERMINAL LABELS	FUNCTION (HEAT PUMP MODE)	FUNCTION (MULTI-STAGE MODE)	COMMENTS
R	24VAC supply	24VAC supply	Hot wire of 24VAC transformer. Powers the thermostat & system.
Y1	Compressor stage 1	Cooling stage 1	Activates the 1st stage compressor. (Heat or Cool for Heat Pumps)
Y2	Compressor stage 2	Cooling stage 2	Activates the 2nd stage compressor.
W1	DO NOT CONNECT	Heating stage 1	Activates the 1st stage of heating for Multi-stage systems ONLY.
W2	Auxiliary heating	Heating stage 2	Activates when auxiliary heating is required on heat pump systems. Activates the 2nd stage of heating for Multi-stage systems.

(continued)

INSTALLATION

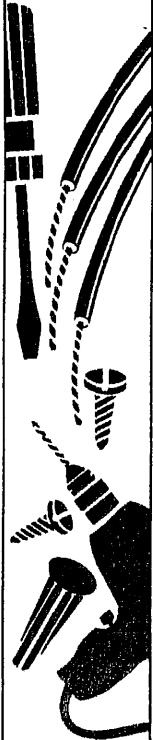

14

TABLE A - TERMINAL DESCRIPTIONS (continued)

TERMINAL LABELS	FUNCTION (HEAT PUMP MODE)	FUNCTION (MULTI-STAGE MODE)	COMMENTS
E	Emergency heating	DO NOT CONNECT	Activates Emergency heating ONLY when the System Switch is in Emergency (em) Mode. (Ignored on Multi-stage systems)
O	Reversing valve (cooling mode)	Cooling damper	Activates reversing valve or damper in COOL mode. ALWAYS ON in COOL MODE.
B	Reversing valve (heating mode)	Heating damper	Activates reversing valve or damper in HEAT mode. ALWAYS ON in HEAT MODE.
G	Fan	Fan	Activates the system Fan. (Can be Auto, On, or Program controlled)
L	System monitor	System monitor	Activates System Check LED on the front of thermostat. (Controlled by the system, not the thermostat.)
C	24VAC common	24VAC common	Common wire of 24VAC transformer. REQUIRED for thermostat operation.
RS1+	Remote temperature sensor 1	Remote temperature sensor 1	Positive (+) Terminal for Remote Sensor #1. Polarity MUST be maintained.
RS1-	Remote sensor 1 (common)	Remote sensor 1 (common)	Negative (-) Terminal for Remote Sensor #1. Polarity MUST be maintained.
RS2+	Remote temperature sensor 2	Remote temperature sensor 2	Positive (+) Terminal for Remote Sensor #2. Polarity MUST be maintained.
RS2-	Remote sensor 2 (common)	Remote sensor 2 (common)	Negative (-) Terminal for Remote Sensor #2. Polarity MUST be maintained.

OPTIONAL

TABLE B
HEAT PUMP CROSS-REFERENCE CHART

EXAMPLES OF DIFFERENT SYSTEM TERMINALS									
CLIMATE TECHNOLOGY TERMINALS	CARRIER	COLEMAN	COMFORTMAKER	BRYANT, PAYNE	RHEEM-RUUD	TRANE, WEATHERTRON	YORK	LENNOX (1)	LENNOX (2)
R	R	R	R	R	R	R	R	R	V-V/R
Y1	Y or Y1	Y	Y	Y	Y	Y	Y	Y	M
W2	W2	W2	W1	W2	W2	W	W	W1	Y
E	E	E	Jumper to W2	E	E	X2	Jumper to W2	E	E
O	O		O	O		O	O	O	R
B		B			B				
G	G	G	G	G	G	G	G	G	F
L	L or F	L	L or X	L	L		X	L	
C	C	X	C, X, X1	C, C1, X1	X	B	B	C	X
		Note: W2 wires no connection				Note: T wires no connection			

NOTE: If your heat pump thermostat does not have an E wire, use the provided jumper wire to connect the E terminal to the W2 terminal, as shown in three examples above. Refer to the Wiring Diagrams on pages 38-39.

INSTALLATION

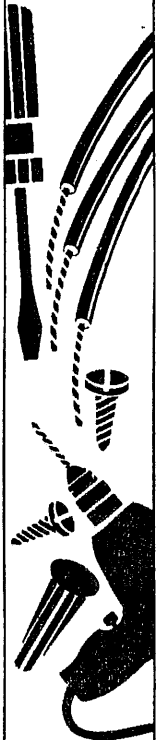

16

Mount Wallplate and Thermostat

- Remove the wallplate from your thermostat by pressing the release tab on the bottom of the thermostat. (See Figure 2.)
- Position wallplate on wall and pull existing wires through large opening. Then level for appearance. Mark holes for plastic anchors provided if your existing holes do not line up with those on the Climate Technology wallplate.

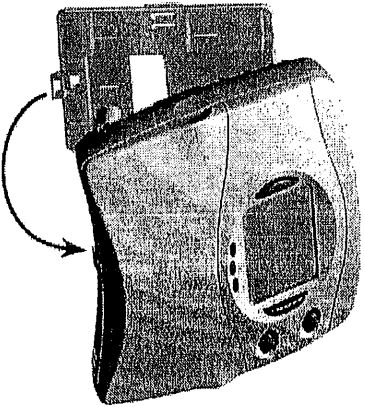

Figure 2

- Drill holes with 3/16" bit and gently tap anchors into the holes until flush with wall.
- Reposition wallplate to wall, pulling wires through large opening. Insert mounting screws provided into wall anchor and tighten. (See Figure 3.)

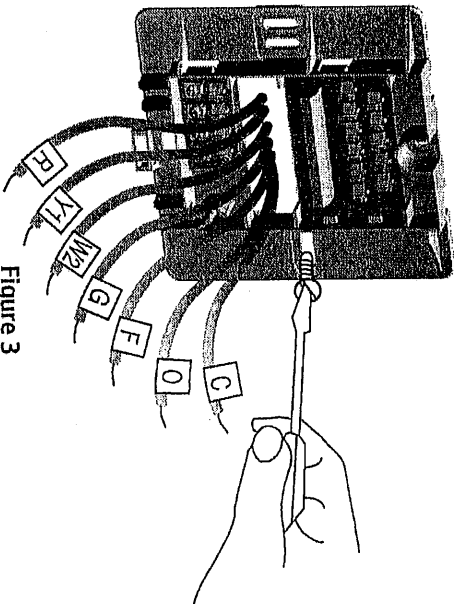

Figure 3

Connect Wires and Mount Thermostat Cover to Wallplate

- Straighten bare end of each wire and cut or strip it to 1/4" maximum. Insert each labeled wire into the bottom of the matching terminal. Refer to figures 4 and 5.
- Hold the wires in each terminal and tighten the terminal screws securely, otherwise a loose wire could cause operational problems with your system or thermostat.
- Push excess wire back into hole to prevent interference with mounting of the thermostat.
- Make sure the Power Switch is set to OFF.
- Insert two AAA size alkaline batteries, observing the polarity marked on the unit.
- Insert the upper tabs on the thermostat body into the slot at the top of the wallplate. Press bottom of the thermostat body to snap it into the wallplate. (NOTE: Do not force the thermostat onto the wallplate, as the terminal pins may be damaged. If it does not snap properly, the thermostat may not work.)
- Switch on the main power at the panel or furnace.

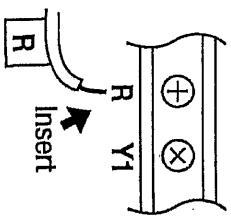

Figure 4

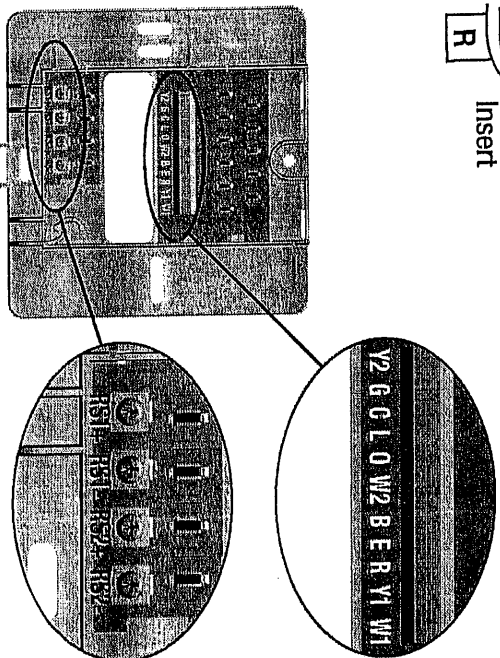

Figure 5

OPERATION

12:41:10

18

Option Menu

Your thermostat has many settings that can be adjusted to fit your system and preferences.



- option** ■ Press to enter the Option Menu and to change to the next option selection.
- ret-clear** ■ Press at any time to return to normal mode.

Local temperature sensor weighting

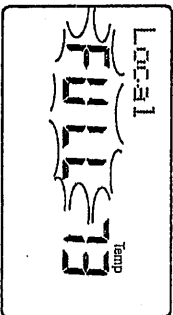
- option 1** ■  or  to change weighting between FULL, HALF or OFF.



Remote temperature sensor 1 weighting

- option 2** ■  or  to change weighting between FULL, HALF or OFF. The factory default is "HALF." The current temperature measurement from sensor 1 is shown. (Blank if not connected.)

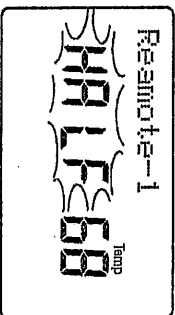

Remote temperature sensor 2 weighting

- option 3** or to change weighting between FULL, HALF or OFF. The factory default is "HALF". The current temperature measurement from sensor 2 is shown. (Blank if not corrected.)

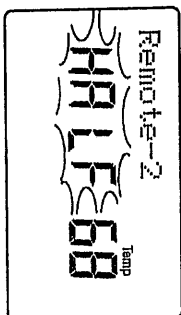

NOTE: Refer to the Remote Sensors section on pages 31-33 for more information on sensor weightings.

Fahrenheit or Celsius (F°/C°) selection

- option 4** or to change the thermostat display between Fahrenheit and Celsius.

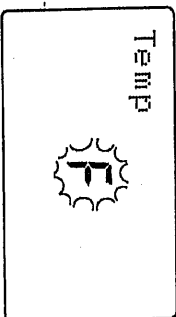

Stage 1 SPAN selection

- option 5** or to change the SPAN setting to 1, 2, or 3. The factory setting is 2. Setting 1 will cause shorter cycle times. Setting 3 will cause longer cycle times.

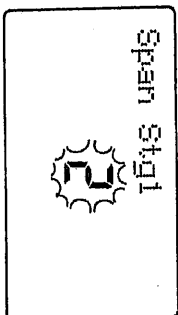

(continued)



OPERATION

12:41:10

20

Option Menu (continued)



Stage 2 SPAN selection

- option 6 ■  or  to change the SPAN setting to 1, 2, 3, 4, 5 or 6. The factory setting is 2. Lower settings will cause the 2nd stage to turn on sooner. Higher settings will cause the 2nd stage to turn on later.

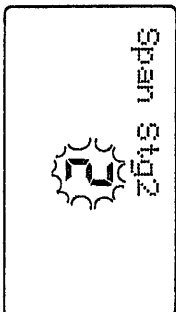
NOTE: Refer to the SPAN section on page 29 for more information on SPAN settings.





Auto Season Changeover Deadband selection

- option 7 ■  or  to change the deadband between 3, 4, 5 or 6°F. The factory setting is 5. (°C are about 1/2°F)

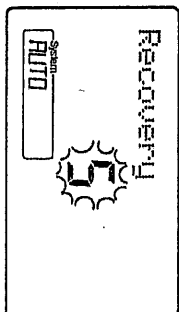
NOTE: Refer to the Auto Season Changeover section on page 27 for more information.



LCD Contrast adjustment

option 8 ■  or  to change the LCD contrast between 0 and 9. Lower numbers lighten the display. Higher numbers darken the display. The factory setting is 5.

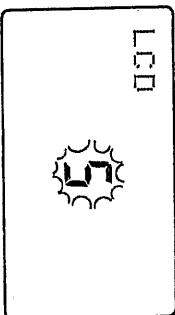

Power Switch

The Power switch on the front of the thermostat determines the operating mode of the thermostat. You may select ON, OFF or Emergency Heat (EM). When the Power Switch is OFF, all outputs are positively disconnected from the system.

NOTE: Anytime you install or remove the thermostat from the wallplate, slide the Power Switch to the OFF position to prevent the possibility of a rapid system On-Off.

NOTE: When Emergency Heat (em) is selected on a multi-stage system, the thermostat will activate both stages of heat (W1 and W2). Thus, the heat control becomes single-stage.

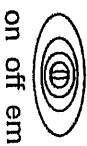

OPERATION

12:41:10

System Selection Key

system

- Press to select the desired system.
- When Auto is selected, the system will change between Heat and Cool automatically. Refer to the Auto Season Changeover section on page 27.

NOTE: The default system selection at power-on or after a reset is HEAT. Therefore it is recommended that 2 AAA batteries be used for backup during power outages.

System **HEAT**

System **AUTO HEAT**

System **COOL**

System **AUTO COOL**

Fan Key

fan

- Press to set the fan operation.
 - AUTO: the fan will turn on with the system. On a multi-stage system, the fan is controlled by the system when the Heating system selector has been set to HG.
- ON: the fan will run continuously.

Fan **AUTO**

Fan **ON**

OPERATION

12:45

24

System Indicator Light

When the thermostat activates your system, LED lights are turned on just below the LCD display.

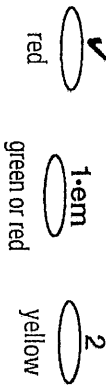

System Monitor This red LCD is controlled by your system and will turn on if there is a problem with your system. It can only work if you have a connection to the L terminal.

Stage 1 Light This LED will turn on in GREEN when the first stage of heat or cool is activated. When in Emergency Heat mode, this LED will turn on in RED when the first stage of emergency heat is activated.

Stage 2 Light This LED will turn ON in YELLOW when the second stage of heat, emergency heat or cool is activated.

The Stage 1/Emergency and Stage 2 LED's will flash On/Off when the corresponding stage is being held off temporarily. For example, during a compressor delay.

Emergency Heat

When the Power Switch is in the "em" position, the thermostat is placed in the Emergency Heat mode. The compressor will not operate in this mode and only auxiliary heat will be used.

When Emergency Heat is selected on a multi-stage system, both stages of heat operate at the same time. So, the heating acts like a single-stage system.

NOTE: Emergency Heat Mode is not an energy saving setting, so use only when necessary.

25

Setting the Thermostat

- Current set temperature and room temperature.
- Thermostat is set to AUTO and the heating system is selected.

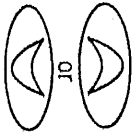

- Press to change set temperature.

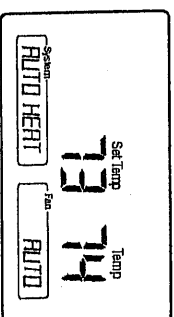
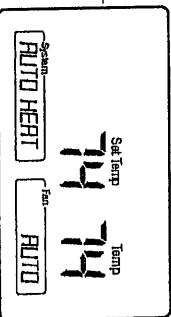

OPERATION

12:45

26

Vacation Hold

This thermostat can hold a different fixed temperature for a selected number of days (up to 30). After the selected number of days, the thermostat will return to normal operation. This feature allows you to return home to your normal comfort setpoint temperatures.

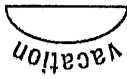

- Press to enter Vacation Hold mode. The set temperature will be the current set temperature and the Vacation counter will be set to 1 day.

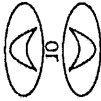

- Use to set the Vacation Hold temperature.



- Press to set the Vacation Hold counter to the number of days you will be away from home.
- "Vacation" will alternate on the display with the day and any other messages.

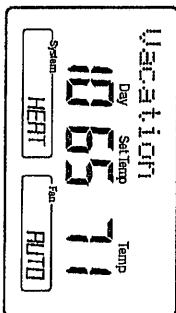

To end Vacation Hold:

ret-clear

- Press to return to the current program. The flashing Vacation display will be canceled.

27

NOTE: The Auto Season Changeover feature will not operate while the thermostat is in Vacation HOLD. Refer to the Auto Season changeover feature below for more information.

Auto Season Changeover

When the System Selection is in AUTO position, the thermostat will automatically change between Heating and Cooling systems. There is a built-in program to prevent the thermostat from changing unnecessarily. This "Deadband" can be adjusted. Refer to the Options Menu section on pages 18-21.

Auto Season Changeover is disabled when the thermostat is in Vacation Hold. While in Vacation Hold, "AUTO" will be temporarily removed from the LCD display. "AUTO" will return when Vacation Hold ends.

For example, you may have the temperature set to 70°F, and the current mode is Heat.

With the factory set deadband of 5, if the room temperature rises above 75°F, then the thermostat will automatically change to cool mode and turn on the air conditioner.

Likewise, the thermostat will automatically change to heat mode and turn on heat when the room temperature falls below 65°F.

OPERATION

12:45

28

Filter Monitor

Your thermostat also keeps a record of the number of hours your filter has been in use. To maximize your system's performance and energy efficiency, change or clean your filter regularly.

- When the total system run time for heat and cool reaches 500 hours, "FILTER" will alternate on the display with the day to remind you to clean or change your system's filter. "FILTER" will continue to display until the counter is set back to zero.



- Press to review total filter usage. After 15 seconds, the display will return to normal mode, or you can hit RET CLEAR to exit immediately. The Filter Monitor will display up to 999 hours and 59 minutes of usage. In this example, the counter is at 410 Hours, 26 minutes.

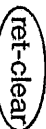

- To reset the Filter Monitor counter, hold for 3 seconds. The display will blink, and the counter will be reset to zero.

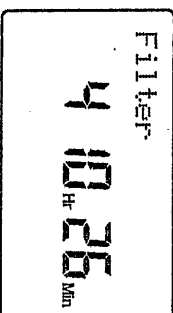
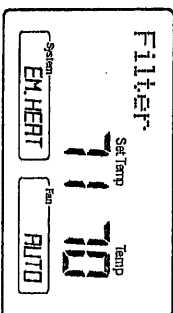

SPAN Settings

29

STAGE 1

Your thermostat is set at the factory to cycle at 1°F (0.5°C) above and below the set temperature in Stage 1. (Span = 2.) This setting has been designed to provide a comfortable room temperature under most all conditions. However, if you find your system cycling too fast or too slow, then the Span can be adjusted to modify the cycle time. Refer to the Option Menu Stage 1 Span selection on page 19.

Span = 1. This decreases the cycle time by causing your system to run shorter.

Span = 3. This increases the cycle time by causing your system to run longer.

The Span settings remain the same for both HEAT and COOL.

The Span can be changed at any time and is independent of program times or temperatures.

When the thermostat is powered on or the Reset key is pressed, the Span is reset back to setting 2.

STAGE 2

The second (or auxiliary) stage turns on when the first stage does not have enough capacity to reach the desired set temperature.

The factory setting for Stage 2 Span is 2. It can be adjusted between 1 to 6; with the second stage being activated sooner at lower numbers and later at higher numbers.

OPERATION

12:45

30

Keyboard Lock

The keyboard can be locked to prevent unauthorized changes to the thermostat.

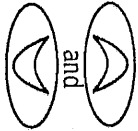

- To lock or unlock the keyboard, press and hold BOTH keys for 3 seconds. The keyboard is locked when KEY LOCK appears on the display.
- All keys are locked, but any time a key is pressed, KEY LOCK will appear on the display for 1 second and the backlight will operate.

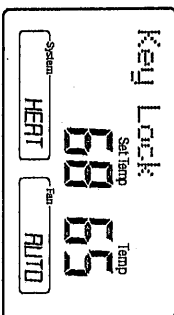

Backlighting (INDIGLO® Night-Light)

Your thermostat has an electroluminescent lamp that backlights the display for easy viewing in the dark.

When any key is pressed the display is illuminated.

The display will remain illuminated for 15 seconds after the last key is pressed. This allows the light to stay on if you need to op-

erate several keys. The backlight will decrease in brightness before shutting off.

NOTE: The backlight is powered by the 24V AC supply. It will not operate when there is an AC power interruption or if the thermostat is removed from the wallplate.

Remote Sensors

This Climate Technology thermostat supports the addition of 1 or 2 optional remote sensors (Model 43658). Along with the sensor inside the thermostat (Local), the displayed room temperature can be a weighted average of these sensors. The Option Menu on pages 18-21 shows how to change the weighting of each sensor.

Description of the weightings:

FULL = The full temperature value is used in the averaging calculation

HALF = Half of the temperature value is used in the averaging calculation

OFF = The temperature is ignored, and not used in the averaging calculation.

How to use the weights to control temperature:

- To take a simple average of all sensors, set all of them to FULL or HALF. (This gives the same result because the weight is the same.)
- To give priority to one area over another, set the priority sensor to FULL and the other 1 or 2 sensors to HALF. (Setting 2 sensors to FULL and the 3rd to HALF gives even more weight to sensors 1 and 2.)

- To control only from the reading of a single Remote sensor, set the desired sensor to FULL, and the other Remote and Local sensor to OFF.

Notes on sensor calculations:

- If the sensor reading exceeds temperature limits ("HI" or "LO") then the maximum or minimum value will be used in the calculation.
- If all 3 sensors are set to OFF, the Local sensor will automatically be set to FULL.
- If there is a problem with the installed remote sensors, then the Local sensor reading will be used for the temperature.

(continued)

OPERATION

12:41:10

32

Remote Sensors (continued)

Detection of Remote Sensors:

- When AC power is present, the thermostat can detect any remote sensors connected. (It may take up to 30 seconds.) "Found RM1" or "RM2" will alternate with the day display.
- The maximum distance a remote sensor can be wired to the thermostat is 328 ft. (100m). For short distances up to 100 ft. (30m), standard thermostat wire will work. For longer distances, or environments with a lot of RF noise, shielded or twisted pair wire should be used.
- If the thermostat has a problem communicating with a remote sensor, then "Check RM1" or "RM2" will alternate with the day display.

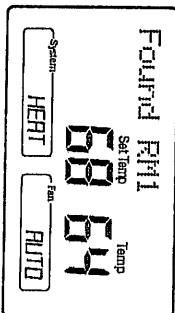



Review Remote Sensor Temperatures:

option

- Press to see the currently measured temperature for each sensor, along with its weight.
- Example: Standard display

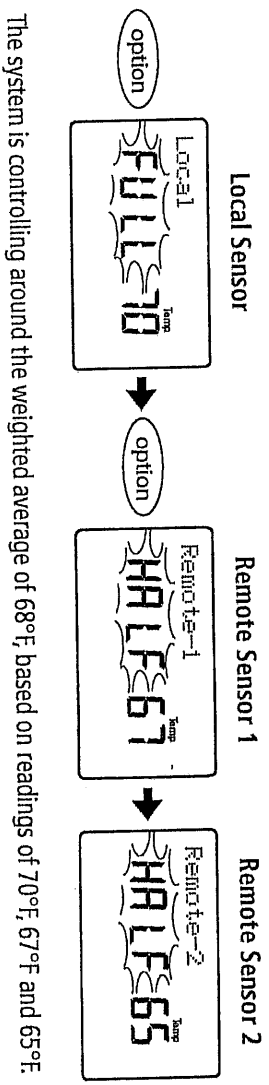
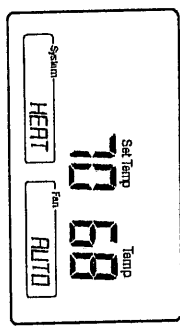

The system is controlling around the weighted average of 68°F, based on readings of 70°F, 67°F and 65°F.

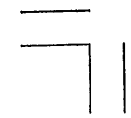
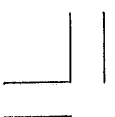

SAFETY FEATURES

34

AC Power Monitor

- This thermostat operates on 24V AC, which is provided by your system's transformer. If the system loses electricity, then the 24V AC power is lost also.
- The 2 AAA batteries provide backup operation of the clock, as well as all programs and settings.
- If the AC power is lost, then the LCD display will alternate "No AC Pwr" with the day. Without AC power, the following functions are disabled:
 - The system is turned off.
 - The Backlight function is disabled.
 - The remote sensor temperature readings are not available.

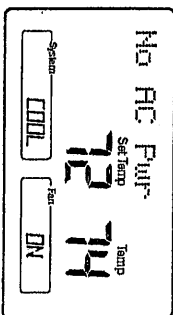

Low Battery Warning

Your thermostat has a low battery warning system. When the batteries are detected to be weak, the low battery warning is indicated by "Low Batt" alternating on the LCD display with the day. You then need to replace the batteries with 2 new

AAA alkaline batteries. You have 30 seconds to change the batteries before the settings are lost.

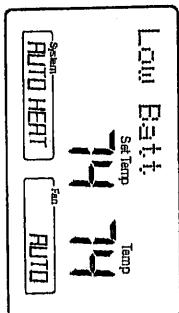

Error Mode

If the thermostat is unable to control your system due to an unexpected problem, the thermostat will enter Error Mode. In this condition, the thermostat flashes "Error" and a code number on the LCD display, and shuts off your system.

To correct this problem, replace the batteries with 2 new AAA alkaline batteries, even if you have recently replaced them. Next, use a paper clip to press the RESET button next

to the keypad. You will need to reprogram your thermostat and confirm normal operation.

If Error Mode returns, please call Climate Technology Technical support at 800-676-7861 for further information.

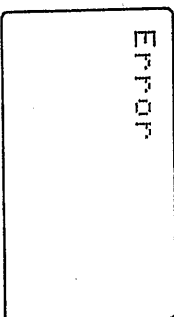

TROUBLESHOOTING

36

Problem

Solution

SCRAMBLED OR DOUBLE DISPLAY
(numbers over numbers)

1. Remove clear Mylar sticker

NO DISPLAY

1. Check terminal connection. A common (C) wire is required for operation.
2. Check battery connections and batteries.
3. Press RESET button with a small pin and hold in for two seconds.

ENTIRE DISPLAY DIMS

1. Replace Batteries
2. Adjust LCD contrast in the Option Menu.

AUTO / FAN DOES NOT TURN ON

1. Move HG/HE selector to opposite position

FAN RUNS CONTINUOUSLY

1. Check fan setting. It may be "ON".

HEATING OR COOLING DOES
NOT GO ON OR OFF

1. Check that the system selector key is in the correct position ("HEAT," "COOL" or "AUTO").
2. The thermostat may be in the AUTO mode. Look for "AUTO" on the LCD display. If the Heat and Cool program temperatures are close, then the thermostat requires a larger room temperature change before changing from Heat or Cool.

Problem (cont.)

HEATING OR COOLING DOES NOT GO ON OR OFF *(cont.)*

Solution (cont.)

37

3. There may be as much as a 4 minute delay before the Heat or Cool system turns On - wait and check. (Compressor protection delay.)
4. Check your circuit breakers and switches to ensure there is power to the system.
5. Replace batteries.
6. Make sure your furnace blower door is closed properly.
7. Check the position of the Heat Pump or Multi-Stage selector switch.

ERRATIC DISPLAY

1. Press the RESET button once with a small pin and hold for two seconds. The thermostat will need to be re-programmed.

IF UNIT CONTINUES TO OPERATE IN THE OFF POSITION

1. Replace unit.

THERMOSTAT PERMANENTLY READS "HI," "LO," OR "Error" AFTER PRESSING RESET BUTTON

1. Replace unit.

If you experience any other problems, call 800-676-7861 from 8 AM to 5 PM Central Time for technical assistance.

WIRING DIAGRAMS

38

HEAT PUMP SYSTEMS

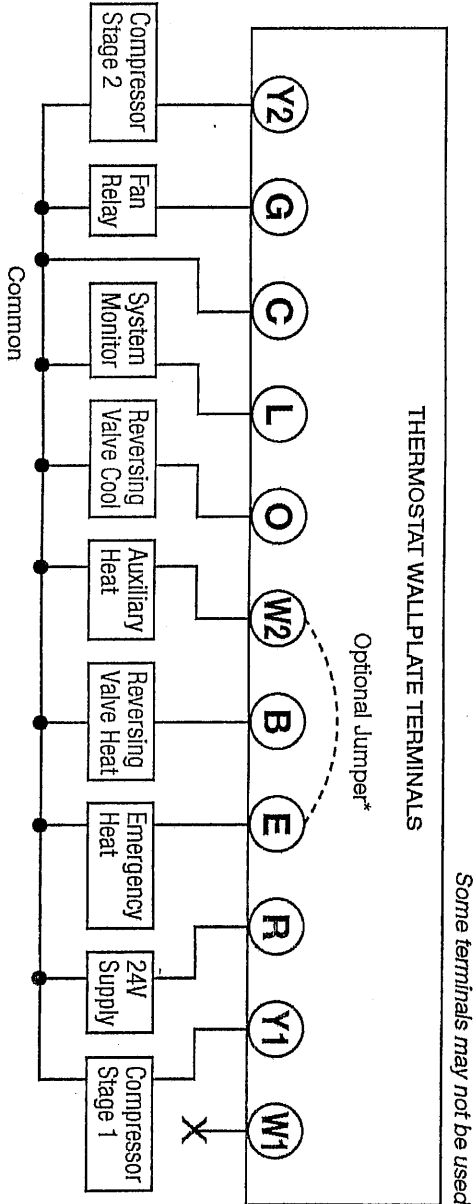

NOTE: Common wire connection is REQUIRED.

X - No Connection

*Add jumper between W2 and E on systems without an E wire.



MULTI-STAGE SYSTEMS

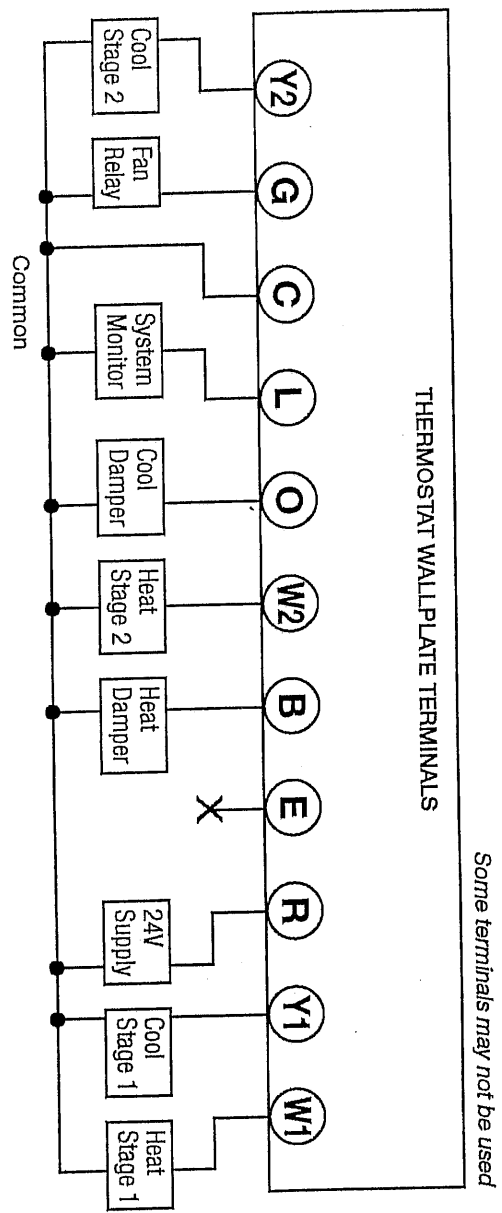

NOTE: Common wire connection is REQUIRED.

X - No Connection

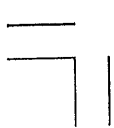



41654-01_final_REV.pmd

40

1/27/04, 12:45 PM



Climate Technology Corp.
2500 FRISCO AVENUE
MEMPHIS, TN 38114

© 2004, Climate Technology Corp Form No. 41654-01, 01/27/04

A Hunter Fan company

