

FQ SERIES

QUIET BATHROOM VENTILATING FANS & FAN LIGHTS

Fantech FQ Series exhaust fans and fan lights provide remarkably quiet, energy efficient ventilation for baths, powder rooms and other areas. Super quiet with as low as < 0.3 sones sound rating. Air performances of 80 to 110 CFM. Fans are designed for intermittent or continuous operation to meet ASHRAE Standard 62.2.

All models are ENERGY STAR® qualified, Title 24 compliant and meet the Washington State Ventilation and Indoor Air Quality Code.

STANDARD FEATURES

- Low profile grille fastened with torsion springs
- Galvanized steel housing with rust-proof paint
- Energy efficient, permanently lubricated PSC ball bearing motor
- Integrated metal backdraft damper
- Thermal overload protection
- 4" duct diameter
- UL Listed for use over a tub/shower with a GFCI branch circuit wiring
- Includes 5 hanger bars for easy positioning between 16" to 24" on-center studs
- The industry's best 5 year warranty

SPECIFICATIONS

FQ80 Quiet Exhaust Fan

HVI Certified: @ 0.1 sp: 80 CFM; < 0.3 sones, 23.4 watts
@ 0.25 sp: 60 CFM; < 0.3 sones, 22.0 watts

FQ110 Quiet Exhaust Fan

HVI Certified: @ 0.1 sp: 110 CFM; 0.7 sones, 26.1 watts
@ 0.25 sp: 85 CFM; 0.7 sones, 26.0 watts

FQ80FL Quiet Exhaust Fan with Light

HVI Certified: @ 0.1 sp: 80 CFM; 0.4 sones, 23.7 watts
@ 0.25 sp: 60 CFM; 0.4 sones, 23.0 watts

FQ110FL Quiet Exhaust Fan with Light

HVI Certified: @ 0.1 sp: 110 CFM; 1.3 sones, 29.4 watts
@ 0.25 sp: 85 CFM; 1.3 sones, 28.5 watts



**FIVE
YEAR
WARRANTY**



CERTIFICATIONS

- ENERGY STAR® qualified fan and light fixture
- The Home Ventilating Institute has certified all models for sound and air performance.
- California Title 24 compliant
- Meets Washington State Ventilation and Indoor Air Quality standards
- Designed for intermittent or continuous operation to meet ASHRAE Standard 62.2.

FAN

- Contemporary design low profile, white polymeric grille
- Galvanized steel housing with rust-proof paint

FAN LIGHT

- Contemporary design low profile, white polymeric grille with frosted light lens
- Galvanized steel housing with rust-proof paint.
- Convenient night light setting
- Include 26 watt CFL bulb
- Include 4 watt night light
- Fan, light and night light can be wired to operate separately

FQ SERIES

QUIET VENTILATING FANS & FAN LIGHTS



DIMENSIONAL DATA

FQ80FL/FQ110FL

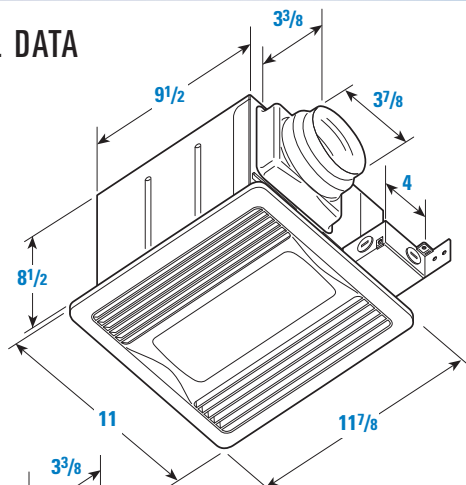

FQ80/FQ110

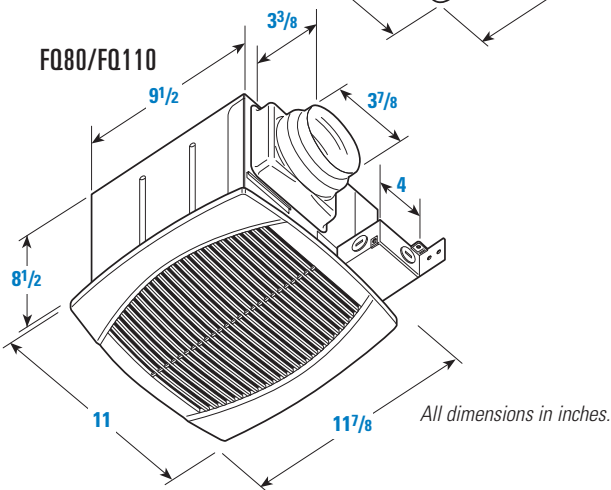

AIR PERFORMANCE GRAPHS

FQ80FL/FQ110FL Fan Lights

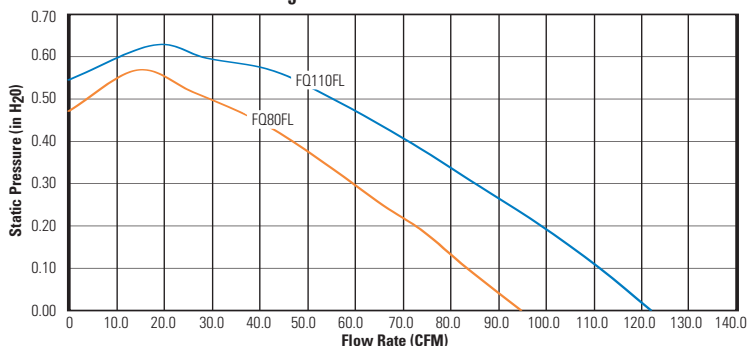

FQ80/FQ110 Fans

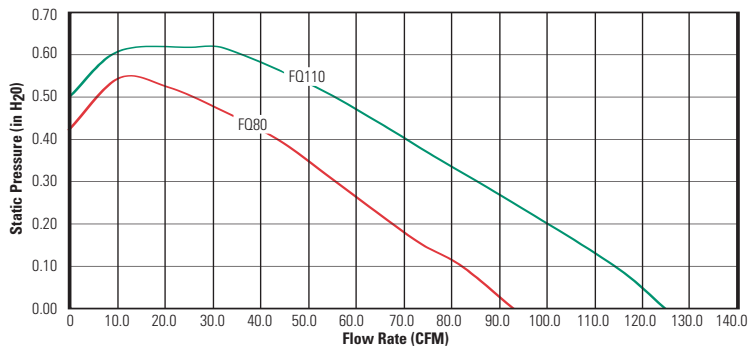

PRODUCT SPECIFICATIONS

Fan Model	Energy Star	Watts	Sones	CFMs 0.1" SP	CFMs 0.25" SP	Lamp Watts (Main)	Lamp Watts (Night Light)	Duct Dia.
Fans								
FQ80	✓	25	<0.3	80	60	—	—	4"
FQ110	✓	30	0.7	110	85	—	—	4"
Fan Lights								
FQ80FL	✓	25	0.4	80	60	26W CFL	4W	4"
FQ110FL	✓	30	1.3	110	85	26W CFL	4W	4"



Fantech

United States 10048 Industrial Blvd. • Lenexa, KS 66215 • 1.800.747.1762 • www.fantech.net
Canada 50 Kanafflakt Way • Bouctouche, NB E4S 3M5 • 1.800.565.3548 • www.fantech.net

Item #: 413671
Rev Date: 072911

Fantech, reserves the right to modify, at any time and without notice, any or all of its products' features, designs, components and specifications to maintain their technological leadership position.