

# CONVERTIBLE INSTALLATION

In this installation the dehumidifier controls humidity in both the whole-home and a spot location. The dehumidifier will dehumidify the whole home as the first priority, switching to the spot location after the whole-home dehumidification need has been met. Ducting the unit to the return and supply, where air is pulled from the return duct, dehumidified, and discharged to the supply duct, is the most common setup, with additional ducting run to and from the spot location(s).

**Note:** Convertible Mode will not work with ventilation, air cycling, or continuous HVAC fan operation. The Model 70 Living Space Control and third-party controls (see pages 16-17) cannot be used in Convertible Mode operation.

## Required Components

- Duct Work
- 18 – 22 AWG Wire
- Grilles with 8" Duct Collars
- 2 – Aprilaire Model 6508, 8" Normally Closed Damper
- 2 – Aprilaire Model 6608, 8" Normally Open Damper
- 24 VAC Transformer (40VA min.) for Dampers

**NOTE:** 4522 Basement Kit includes 2 – 6508 Dampers, 2 – 6608 Dampers and a 24 VAC Transformer.

## Optional Component

- Condensate Pan & Normally Closed Float Switch

## DUCTING & WIRING

**FIGURE 16 – Convertible Installation**

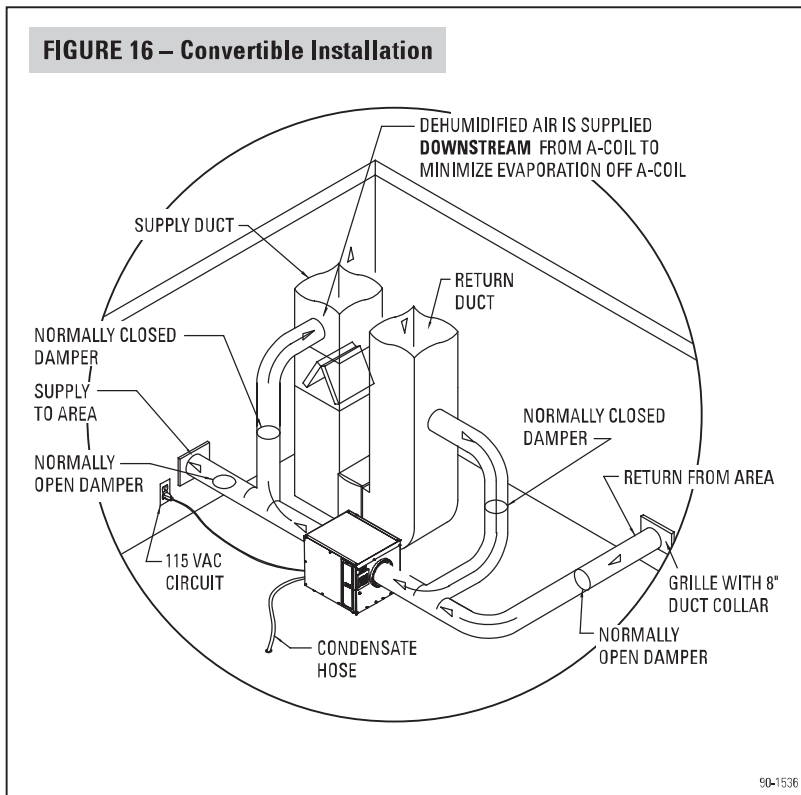

**FIGURE 17 – Convertible Wiring**

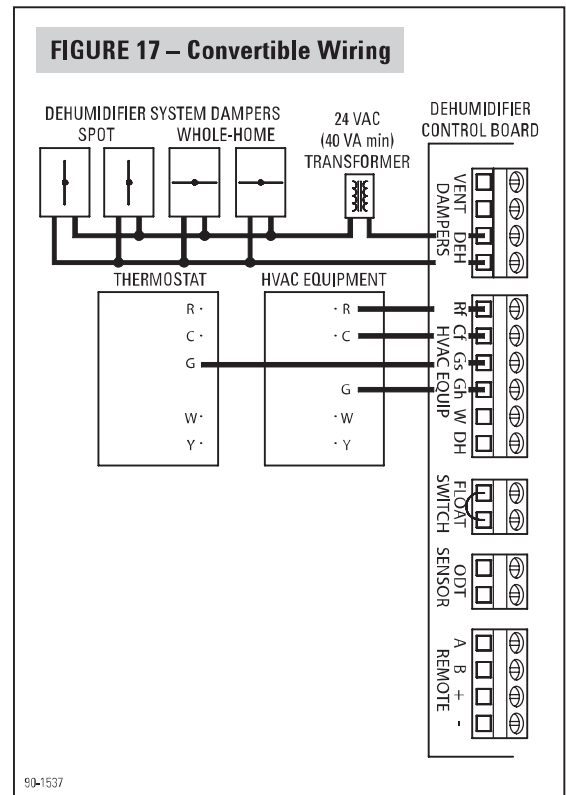

## CONVERTIBLE INSTALLATION (CONTINUED)

### DIP SWITCH CONFIGURATION

- **HVAC FAN ON:** Activating the HVAC fan during Whole-Home dehumidification is recommended because it offers better circulation and balancing of indoor air conditions. Running the HVAC fan during dehumidification does not affect moisture removal efficiency. During spot dehumidification, the HVAC fan will not be turned on regardless of the position of the switch. If the switch is put in the HVAC FAN OFF position, air is pulled through the unit, dehumidified, and circulated solely by the dehumidifier blower.
- **CYCLE PERIOD:** This determines how frequently the dehumidifier will sample the air to check the humidity level. Set to 1 hour and adjust as needed.
- **CYCLE TIME:** The cycle time potentiometer must be set to OFF for proper operation.

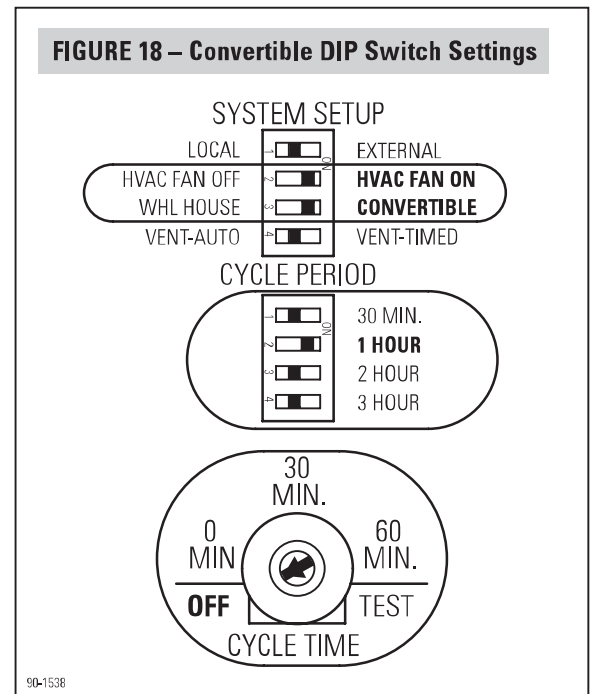

### SEQUENCE OF OPERATION

- Whole-Home sampling will occur with the first HVAC fan (Gs) call within the Cycle Period and will override Spot dehumidification.
- At the onset of Whole-Home sampling, the dehumidifier damper output turns on, the dehumidifier blower turns on, and the green Status LED flashes. After three minutes, the dew point of the incoming air is measured and compared to the set point on the control knob. If the dew point of the incoming air is above the set point, the compressor turns on and the green Status LED switches to solid illumination. If the dew point is below the set point, the dehumidifier damper output turns off and the dehumidifier blower turns off along with the green Status LED.
- If a Whole-Home sampling does not occur, Spot sampling will occur at the end of the Cycle Period, if not actively dehumidifying the whole-home. At the onset of spot sampling, the dehumidifier blower turns on and the green Status LED flashes. After three minutes the dew point of the incoming air is measured and compared to the set point on the control knob. If the dew point of the incoming air is above the set point, the compressor turns on and the green Status LED switches to solid illumination. If the dew point is below the set point, the dehumidifier blower turns off along with the green Status LED.
- The dew point of the incoming air is continuously monitored during compressor operation. When the dew point of the incoming air falls below the set point on the control knob, the dehumidifier damper output turns off and the dehumidifier compressor and blower turn off along with the green Status LED.
- After the dehumidifier blower has turned off, one minute must elapse before it can be turned on again (i.e., following a Whole-Home sampling). If one minute has not elapsed, the Status LED will flash and the dehumidifier blower will turn on after one minute.