

Builder Series Non-Programmable Thermostats

MODEL 1000 Single Stage Heat / Cool
Conventional and Heat Pump

MODEL 1200 Multi-Stage 2 Heat / 1 Cool
Conventional and Heat Pump

**Before Installing, Programming or Operating,
PLEASE READ ALL INSTRUCTIONS**

- | | |
|--------------------------------------|--|
| 1 Specifications | 5 Additional Operation Features |
| 2 Installation | 6 Troubleshooting |
| 3 Testing Your New Thermostat | 7 Wiring Diagrams |
| 4 Programming User Settings | |

WARNING

Important Safety Information

- Always turn off power to the air conditioning or heating system prior to installing, removing, cleaning or servicing thermostat.
- This thermostat is a dual power thermostat and either requires 24 Volts AC Power or two (2) properly installed "AA" alkaline batteries for normal operation and control of the heating or cooling system.
- This thermostat should only be used as described in this manual. Any other use is not recommended and will void the warranty.

1 Specifications

- Electrical Rating: 24 Volt AC (18-30 Volt AC)
1 amp maximum load per terminal
2 amp total maximum load (all terminals) (Model 1000)
3 amp total maximum load (all terminals) (Model 1200)
- Control Range: 45° - 90° F (7° - 32° C)
- Accuracy: +/- 1° F (+/- .5° C)
- AC Power: 18-30 Volt AC
- DC Power: 3.0 Volt DC (2 AA Alkaline batteries included)

1 Specifications *cont.*

- **Model 1000:** Compatibility with low voltage single stage gas, oil or electric heating or cooling systems, including single stage heat pumps, can also be used on 250mv to 750mv millivolt heating only systems.
- **Model 1200:** Compatibility with low voltage multi-stage gas, oil or electric heating or cooling systems, including multi-stage heat pumps.
- **Terminations, Model 1000:** Rc, Rh, B, O, Y, W, G, C
- **Terminations, Model 1200:** R, O, B, C, Y1, E/W1, G, W2

2 Installation

Replacing Existing Thermostat

1. Always turn off power to the air conditioning or heating system prior to removing existing thermostat.
2. Remove the cover of your old thermostat and locate the wire terminals. Do not remove wires from terminals yet.
3. Using small pieces of masking tape, label wires prior to removal from terminals. Use the chart below to determine the new terminal designations for your new thermostat.

| Old Terminal from Existing Thermostat | New Terminal for New Thermostat (Model 1000) | New Terminal for New Thermostat (Model 1200) | Terminal Description |
|---------------------------------------|--|--|-------------------------------------|
| V or Rc | Rc | | Cooling Transformer |
| M, 4, Rh, or R | Rh | | Heating Transformer |
| R, V-VR or VR-R | | R | 24 VAC |
| B | B | B | Reversing Valve (Heating) |
| O | O | O | Reversing Valve (Cooling) |
| Y, Y1 or M | Y | Y1 | Cooling or Compressor for HP System |
| E, H, W, or 4 | W | E/W1 | 1st Stage Heat or Emergency Heat |
| G or F | G | G | Fan Control |
| C, X or B | C | C | 24 VAC Common |

4. After labeling and removing all wires from terminals, unscrew the existing thermostat sub-base from wall. Secure wires to prevent them from slipping into the hole in the wall.

NOTE—MODEL 1000: This thermostat is designed for use with 24 Volt-AC low voltage single stage gas, oil or electric heating or cooling systems, including single stage heat pumps and can also be used on 250mv to 750mv millivolt heating only systems. Do not use this thermostat on applications with voltages above 30 Volts AC.

NOTE—MODEL 1200: This thermostat is designed for use with 24 Volt-AC low voltage multi-stage gas, oil or electric heating or cooling systems, including multi-stage heat pump systems. Do not use this thermostat on applications with voltages above 30 Volts AC.

2 Installation *cont.*

Installing Your New Thermostat

NOTE: If installing this thermostat in a new installation, locate the thermostat 4 to 5 feet above the floor in accordance with applicable building codes. Install the thermostat in a location that provides good airflow characteristics and avoid areas behind doors, near corners, air vents, direct sunlight or heat generating devices. Installation in these areas could impact thermostat performance.

Wiring must conform to all building codes and ordinances as required by local and national code authorities having jurisdiction.

1. Turn off power to the air conditioning or heating system prior to installing thermostat.
 2. Place system switch on front of thermostat to **OFF** position.
 3. Place fan control switch on front of thermostat to **AUTO** position.
 4. Remove front of thermostat body from sub-base by pressing release latch.
 5. Place the thermostat sub-base against wall in the desired thermostat location.
 6. Guide thermostat wires through hole in sub-base. Continue to hold against wall.
 7. Mark placement of mounting holes as appropriate and drill using a 3/16" drill bit.
 8. Gently tap supplied plastic anchors into the holes in the wall.
 9. Place the thermostat sub-base against the wall in the desired location, making sure the mounting holes are aligned and the thermostat wires are inserted into the opening in sub-base.
 10. Fasten sub-base to wall using supplied screws.
 11. Connect wires to quick wiring terminal block using the new terminal designations. See section 7.
 12. Make sure all of the wire connections are secure and not touching any other terminal to prevent electrical shorts and potential damage to the thermostat.
 13. Turn the front thermostat body over, exposing the rear view of the circuit board.
 14. Locate the internal °F / °C switch on the circuit board. Using your fingers, flip the switch toward the preferred temperature °F / °C scale.
 15. Locate the internal fan option switch, **HG** (Gas) / **HE** (Elec) on the circuit board. This switch controls the heating system fan delay. Select gas for gas or oil fired systems. This will allow the furnace to run for a few seconds before initiating the fan. Select electric for systems with electric furnace elements that require the fan to come on immediately. Using your fingers, flip the switch toward **HG** (Gas) or **HE** (Elec).
- NOTE:** For heat pump systems, the fan option switch should be set according to the second stage heating system type.
16. Locate the internal **NORM** / **HP** switch on the circuit board. This switch configures the thermostat for conventional (NORM) heating and cooling systems or heat pump (HP) systems. Using your fingers, gently flip the switch toward **NORM** or **HP**.
 17. Attach front body of thermostat to sub-base of thermostat, being careful to align the terminal pins on the front body with the terminal block on the sub-base.
 18. Open front thermostat door and open battery compartment door.
 19. Install two new "AA" alkaline batteries. Locate the positive (+) ends of the batteries and match them with the positive (+) terminals located in the battery compartment. Close battery compartment.
 20. Restore system power so you can test installation.

2 Installation *cont.*

NOTE: If the thermostat was powered (batteries installed) prior to accomplishing steps 14 through 16, you will need to reset the thermostat to register thermostat switch configurations prior to programming any user settings. Gently press the **RESET** button on the front of the thermostat using a paperclip or a small pencil tip.

NOTE – MODEL 1200: If the thermostat is configured for a conventional system and the system switch is in the **EM HEAT** position, the unit will still function in a conventional 2 stage **HEAT** mode, but the display will flash **NO AUX SET**.



3 Testing Your New Thermostat

WARNING! Read *BEFORE* Testing

- Do not short (or jumper) across terminals on the gas valve or at the heating or cooling system control board to test the thermostat installation. This could damage the thermostat and void the warranty.
- Do not select COOL mode if the outside temperature is below 50° F (10° C). This could damage the controlled cooling system and cause personal injury.
- This thermostat includes an automatic compressor protection feature to avoid potential damage to the cooling system from short cycling. This thermostat automatically provides a 5-minute delay after turning off the cooling or heating system output to protect the compressor.

NOTE: Test your thermostat prior to programming any user settings. Pressing the **RESET** button will erase any user entries previously programmed and return them to their default values.

1. Place the system switch in the **HEAT** position.
2. Press the **▲** button on the keypad until the set point temperature setting is a minimum of 3 degrees higher than the current room temperature. The heating system should start within several seconds. The fan may not turn on immediately due to the heating system built-in fan delay.
3. Place the system switch in the **OFF** position. The heating system should stop within several seconds with conventional heating or cooling systems. On heat pump systems you must wait 5 minutes for the automatic compressor short cycle protection period to expire, or press the **RESET** button to bypass this feature for initial testing purposes. Pressing the **RESET** button will erase any user program settings.
4. Place the system switch in the **COOL** position.
5. Press the **▼** button on the keypad until the set point temperature is a minimum of 3 degrees lower than the current room temperature.
6. The cooling system should start within several seconds. Place the system switch in the **OFF** position. The cooling system should stop within a few seconds.
7. Place the fan switch in the **ON** position. The system blower should start.
8. Place the fan switch in the **AUTO** position. The system blower should stop.

4 Programming User Settings

Default Thermostat Settings

| Function | Status After Reset |
|------------------------------|---|
| Operation Mode | Normal Operating Mode |
| Room Temperature | 70° F (21.0° C), to be renewed within 5 seconds |
| Set Point Temperature | <u>According to system switch</u> Heat or Off: 62° F (17.0° C) Emergency Heat (model 1200 only): 62° F (17.0° C) Cool: 85° F (29.0° C) |
| Temperature Scale | °F or °C dependent switch setting |
| Low Battery Warning | Off, to be renewed within 5 seconds. Off if 24V is present |
| 1st Stage Differential | 0.5° F (0.25° C) |
| 2nd Stage Differential | 2° F (1.0° C) |
| Short Cycle Protection Timer | Reset |
| Output Relays | Off |

Setting Temperature Differentials

The default settings for the first and second stage differentials are compatible with most systems and applications. This is normally set at time of installation and usually does not require any modification under normal operating conditions. If you feel that your system is turning on too often, simply follow the instructions below.

NOTE: The first and second stage differential settings are the same for both the heating and cooling systems.

Setting First Stage Differential

The default setting is 0.5° F (0.25° C). The room temperature must change .5° F (0.25° C) from the set point temperature before the thermostat will initiate the system in heating or cooling.

1. In normal operating mode, press and hold the **▲** and **▼** buttons at the same time for 3 seconds. LCD display will show "**SET D1 x°**", where "x" equals the °F / °C differential setting. This is the current first stage differential setting.
2. Press the **▲** or **▼** buttons to set the first stage differential to your desired setting of .5°, 1°, or 2° F (.25—displayed as .3°, .5° or 1.0° C).

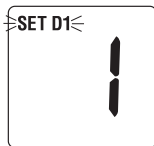

NOTE—MODEL 1000: Once you have finished setting the first stage differential, you can wait 5 seconds and the thermostat will return to the normal operating mode. Or you can press both the **▲** and **▼** buttons at the same time to return to normal operating mode.

NOTE—MODEL 1200: If you do not wish to change the second stage differential, you can wait 5 seconds and the thermostat will automatically return to the normal operating mode. Otherwise, you can press both the **▲** and **▼** buttons at the same time to return to normal operating mode.

4 Programming User Settings *cont.*

Setting Second Stage Differential

The default setting is 2° F (1.0° C). The room temperature must change 2° F (1.0° C) in addition to the first stage differential setting before the thermostat will initiate the second stage of the system in heating.

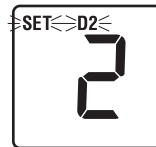

3. Press and hold the **▲** and **▼** buttons at the same time again and the LCD display will show "**SET D2 x°**", where "x" equals the °F / °C differential setting. This is the current second stage differential setting.
4. Press the **▲** or **▼** buttons to set the second stage differential to your desired setting of 2°, 3°, 4°, 5° or 6° F (1°, 1.5°, 2°, 2.5° or 3° C).

NOTE – MODEL 1200: Once you have finished setting the second stage differential, you can wait 5 seconds and the thermostat will return to the normal operating mode. Or you can press both the **▲** and **▼** buttons at the same time to return to normal operating mode.

NOTE: To erase all user program settings, gently press the **RESET** button using a paper clip or a small pencil tip. This will return all thermostat settings to their default values, erasing all program settings entered by the user.

5 Additional Operation Features

NOTE: This thermostat has separate heating and cooling set points, which can be reviewed or changed by selecting either **HEAT** or **COOL** with the system switch.

Review Set Temperature

1. Press and hold the **▲** or **▼** button. The current set point temperature will be displayed in place of the current room temperature, and the indicator **SET** will be displayed.
2. The display will return to normal operating mode when the **▲** or **▼** buttons are released. The **SET** indicator will turn off, indicating that the current temperature shown in the display is the room temperature.

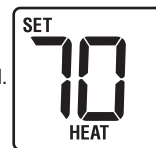

Changing Set Temperature

1. Press and hold the **▲** or **▼** button for more than 1 second. The entire display will flash once and the **SET** indicator will be flashing. Release the **▲** or **▼** button and press the **▲** or **▼** button again to adjust the set temperature.
2. The display will return to normal operating mode after 5 seconds, or you can press both the **▲** and **▼** buttons at the same time to return to normal operating mode.
3. The **SET** indicator will turn off in the display, indicating that the current temperature shown in the display is the room temperature.

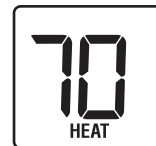

5 Additional Operation Features *cont.*

Compressor Protection Feature

This thermostat includes an automatic compressor protection feature to avoid potential damage to the system from short cycling. This thermostat automatically provides a 5-minute delay after turning off the cooling system output to protect the compressor. This protection is also present in the heat mode of operation on heat pump systems to protect the compressor.

NOTE: The installer can bypass the compressor protection feature by pressing the **RESET** button. This will erase all user program settings, returning all settings to their default values. This should only be used during installation for testing purposes or to reset a thermostat to regain normal operation.

Low Battery Detection and Replacement

This thermostat requires two (2) properly installed "AA" alkaline batteries to provide power for the thermostat if 24 volt AC power is not connected to the terminal block. This thermostat is equipped with a unique, three level low battery detection feature that constantly monitors the batteries during normal operating mode to determine whether they have sufficient power to provide proper operation.

When this feature determines that the battery status is low, a low battery indicator will appear in the display. After 30 days the battery indicator will start to flash, and after 60 days the battery indicator will begin to flash faster, indicating that the batteries need to be replaced immediately to maintain system operation and program settings.

Replacing the Batteries

1. Open front cover and locate the battery compartment door.
2. Gently remove the two "AA" alkaline batteries located in the battery compartment.
3. Install two new "AA" alkaline batteries into battery compartment. Make sure to match the positive (+) ends of the batteries with the positive (+) terminals located in the battery compartment.
4. Close battery compartment. The low battery indicator should not appear in display.



Non-Volatile Memory

In the event of a power failure, the Non-Volatile Memory feature allows all settings to be recovered, eliminating the need to reset temperature and differential settings. When AC power is restored after an outage or batteries are reinserted, all settings are retrieved from memory and reinstated.

Status Indicators (Model 1200 Only)

There is one status indicator that can be displayed to notify you of key system information.

AUX: This will turn on when the auxiliary second stage of heating is active. The auxiliary stage of heating is usually the least economical stage of heat.



6 Troubleshooting

Symptom: *Thermostat does not turn on heating or cooling system.*

Potential Solution: Check to see if **OFF** is shown in display. This indicates that the system is turned off at the thermostat. Move system selector switch to **HEAT** or **COOL** position. After the compressor short cycle protection 5-minute period expires, the system should start.

Compressor protection feature may be in effect due to compressor short cycle conditions. See Section 5.

Heating or cooling system may be malfunctioning. Call a professional service technician immediately to verify system operation.

Symptom: *Thermostat turns on heating instead of cooling, or cooling instead of heating.*

Potential Solution: Check thermostat wiring to make sure the heating and cooling stages are connected to the correct terminals on the wiring block. See Section 7.

Symptom: *Thermostat turns heating or cooling system on too often or not often enough.*

Potential Solution: Increase or decrease temperature differential settings as appropriate to provide the desired performance level. See Section 4.

Symptom: *Low battery indicator is blinking in thermostat display.*

Potential Solution: Replace batteries immediately to maintain proper system operation. See Section 5.

Symptom: *OFF is shown in thermostat display and heating or cooling system will not start.*

Potential Solution: This indicates that the system is turned off at the thermostat. The thermostat must be in **HEAT** or **COOL** mode of operation to control the heating or cooling system. Move the system selector switch to the **HEAT** or **COOL** position.

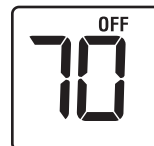

Symptom: *Thermostat display is blank.*

Potential Solution: It is possible that AC power is not present at the thermostat, and/or the batteries are drained. Check fuse, circuit breaker and thermostat wiring as appropriate to verify AC power is available. Replace batteries before reprogramming thermostat. See Section 5. If AC power is present, call a professional service technician to verify thermostat and system performance.

Symptom: *HI is shown in the thermostat display.*

Potential Solution: The temperature sensed by the thermostat is higher than the 99° F (37° C) upper limit of the thermostat's display range. The display will return to normal after the sensed temperature lowers within the 40° to 99° F (4° to 37° C) display range. Turn on the cooling system or use other methods to lower the temperature accordingly.



This condition could occur from the system being turned off during an exceptionally warm period or upon installation when the thermostat has been stored for a long period of time in a warm vehicle or location prior to being installed.

Symptom: *NO AUX SET is shown in the thermostat display. (model 1200 only)*

Potential Solution: The thermostat (model 1200 only) is configured for a conventional system, and the system switch is in the **EM HEAT** position. The unit will still function in a conventional 2 stage **HEAT** mode, but the display will flash **NO AUX SET**. Move the system switch to the **HEAT** position.



6 Troubleshooting *cont.*

Symptom: *LO* is shown in the thermostat display.

Potential Solution: The temperature sensed by the thermostat is lower than the 40° F (4° C) lower limit of the thermostat's display range. The display will return to normal after the sensed temperature rises within the 40° to 99° F (4° to 37° C) display range. Turn on the heating system to raise the temperature as needed for comfort within the room.



This condition could occur from the system being turned off during a cold weather period or upon installation when the thermostat has been stored for a long period of time in a cold vehicle or location prior to being installed. The thermostat should be allowed to warm up prior to installation to allow proper heating control once installed.

Symptom: *Cannot program a set point temperature higher than 90° F (32° C).*

Potential Solution: This is above the normal thermostat temperature setting range of 45° to 90° F (7° to 32° C).

Symptom: *Cannot program a set point temperature lower than 45° F (7° C).*

Potential Solution: This is below the normal thermostat temperature setting range of 45° to 90° F (7° to 32° C).

Symptom: *Fan continues to run whether the system is on or off.*

Potential Solution: Check that the fan control switch is in the **AUTO** position. This will allow the fan to run only when the heating or cooling system is turned on and running. Check thermostat wiring to make sure that the fan control wiring is connected to the correct terminals on the wiring block. See Section 7.

Symptom: *The room is too warm or too cold.*

Potential Solution: See Section 5. Review current set point and change as necessary.

7 Wiring Diagrams

MODEL 1000: Single Stage Conventional Systems (Single Transformer)

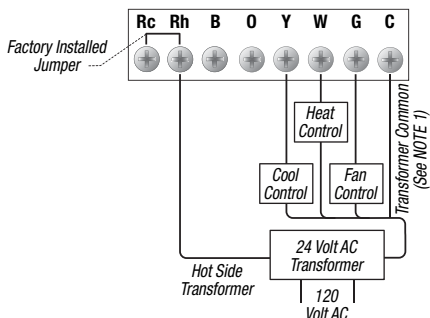

NOTES: 1. Transformer common not required for battery-only operation of thermostat. 2. For heating or cooling only system, ignore opposite connection. 3. For 2-wire 24 Volt AC or 250 mV - 750 mV millivolt heating systems, ignore cooling connection and fan control.

7 Wiring Diagrams *cont.*

MODEL 1000: Single Stage Conventional Systems (Dual Transformer)

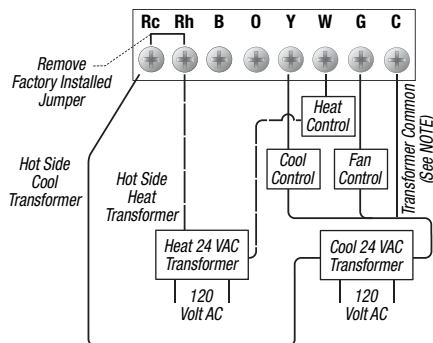

NOTE: Transformer common not required for battery-only operation of thermostat.

MODEL 1000: Single Stage Heat Pump System

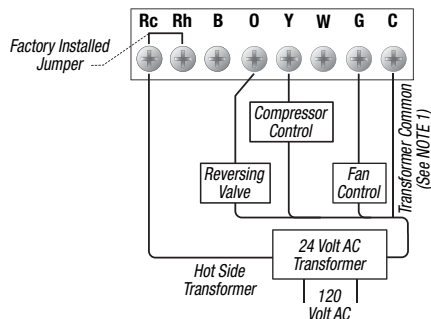

NOTES: 1. Transformer common not required for battery-only operation of thermostat. 2. For reversing valve active in heating use B terminal instead of O terminal.

7 Wiring Diagrams *cont.*

MODEL 1200: Conventional Systems (Single Transformer)

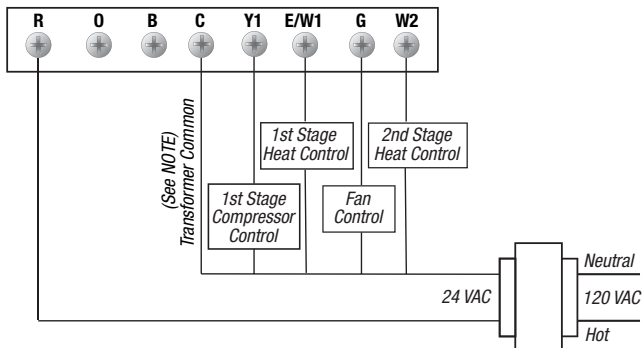

NOTE: Transformer common not required for battery-only operation of thermostat.

MODEL 1200: Multi-Stage Heat Pump Systems

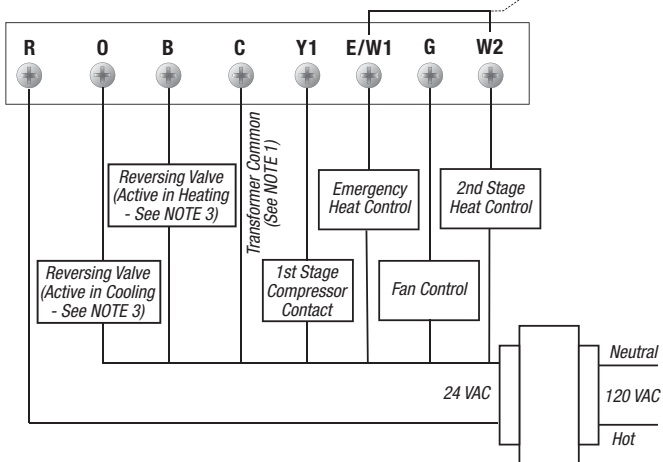

NOTES: 1. Transformer common not required for battery-only operation of thermostat. 2. Jumper is required to use Auxiliary Heat for both Second Stage and Emergency Heat on units without separate Emergency Heat and Auxiliary Heat terminals. 3. For units requiring reversing valve to be energized during heating, connect reversing valve to B terminal. For units requiring reversing valve to be energized during cooling, connect reversing valve to O terminal.

Braeburn®

5 YEAR
LIMITED
WARRANTY

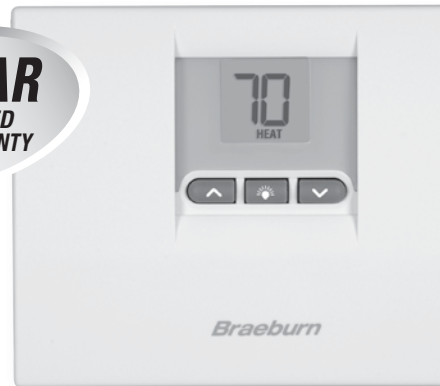

**Store this
booklet for
future reference**

Braeburn Systems LLC warrants each new Braeburn thermostat against any defects that are due to faulty material or workmanship for a period of five years after the original date of purchase by a professional service technician. This warranty and our liability does not apply to batteries, nor does it include damage to merchandise or the thermostat resulting from accident, alteration, neglect, misuse, improper installation or any other failure to follow Braeburn installation and operating instructions.

Braeburn Systems LLC agrees to repair or replace at its option any Braeburn thermostat under warranty provided it is returned postage prepaid to our warranty facility in a padded carton within the warranty period, with proof of the original date of purchase and a brief description of the malfunction. This limited warranty does not include the cost of removal or re-installation.

This warranty gives you specific legal rights and you may also have other rights that vary from state to state or province to province. Answers to any questions regarding our limited warranty may be obtained by writing our corporate offices.

WARRANTY FACILITY: Braeburn Systems LLC
Attn: Warranty Department
2215 Cornell Avenue
Montgomery, IL 60538

Braeburn®

Braeburn Systems LLC
2215 Cornell Avenue • Montgomery, IL 60538
Technical Assistance: www.braeburnonline.com
Call us toll-free: 866-268-5599 (U.S. Only)
630-844-1968 (Outside the U.S.)